

PCI595 – PCIe FPGA Carrier for FMC, Virtex UltraScale™

PCIe FMC Carrier, Virtex UltraScale™



KEY FEATURES

- PCIe FPGA carrier for FMC per VITA-57
- Xilinx Virtex Ultra Scale™ XCVU440 FPGA
- Ideal for ASIC prototyping/emulation and 100G transponder/muxponder
- Active cooling for FPGA and FMC
- Dual x8 lanes for direct connection to neighbouring FPGA card(s)
- Single banks of 64-bit wide 8 GB DDR-4
- RoHS compliant

Benefits of Choosing VadaTech

- Based on the widely-used VadaTech AMC595
- Strong BSP support and example code to support system bring-up
- Wide range of compatible FMCs, including ADC, DAC and networking
- Electrical, mechanical, software, and system-level expertise in house
- Full system supply from industry leader
- AS9100 and ISO9001 certified company

The PCI595 is based on the Xilinx XCVU440 Virtex UltraScale FPGA, which provides 2,880 DSP slices, 88.6 Mb RAM and 5,541,000 logic cells. The FPGA interfaces directly to the FMC DP 0-9 and all FMC LA/HA/HB pairs, making it compatible with a wide range of industry standard VITA-57 modules. The PCI595 provides active cooling of the FPGA and FMC, making it appropriate for power-hungry applications or those requiring temperature stability for good performance.

The FPGA has interface to one DDR4, 64-bit wide, with 8 GB total memory. This allows for large buffer sizes to be stored during processing as well as for queuing the data to the host.

The PCI595 has x8 PCIe edge connector routed to the FPGA PCIe Gen3 hard IP block. In addition, 16 uncommitted connection pairs are routed to a dual x8 expansion connector, providing direct connectivity to a neighbouring FPGA (e.g. via Aurora, 10G/40G, SRIO, PCIe) without the need to go through the host.

REFERENCE DESIGN

VadaTech provides a reference design implementation for our FPGAs, complete with VHDL source code and configuration binaries. The reference design focuses on the I/O ring of the FPGA to demonstrate low-level operation of the interconnections between the FPGA and other circuits on the board and/or backplane. It is intended to prove out the hardware for engineering/factory diagnostics and customer acceptance of the hardware, and can be used as a starting point for developing an end application.

COMPATIBLE FMC

VadaTech offers VITA-57 compatible FMCs providing ADC, DAC, RF transceivers and network interfaces. These FMCs are widely deployed in commercial and mil/aero form factors. Please contact VadaTech Sales for more information.

BLOCK DIAGRAM

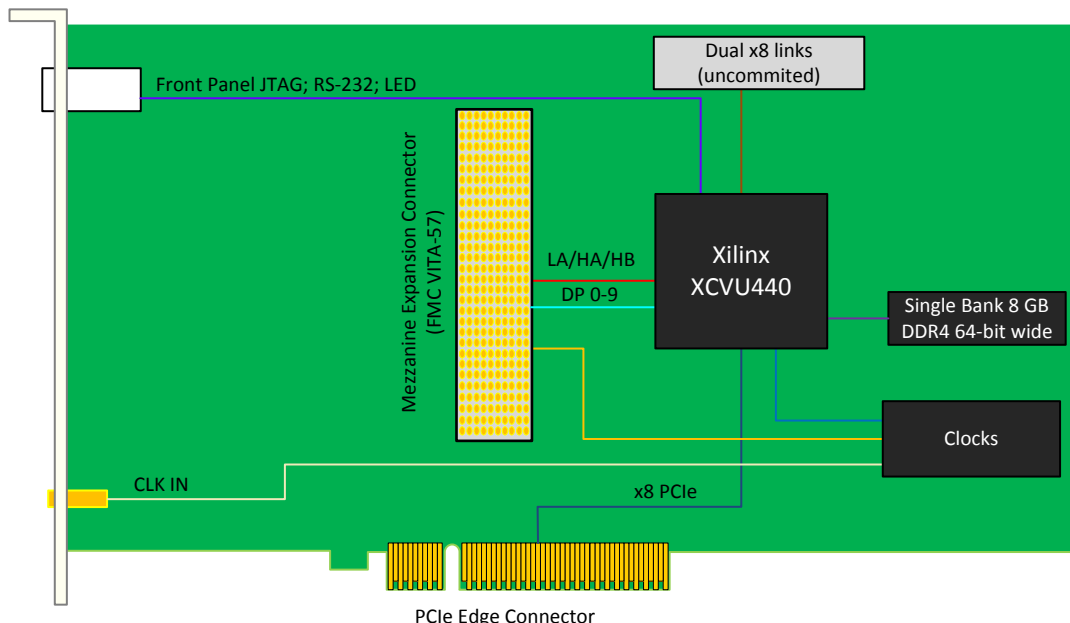

Figure 1: PCI595 Functional Block Diagram

SPECIFICATIONS

Architecture		
Physical	Dimensions	Single Module
		Width: 4.36" (110.74 mm)
		Depth 12.28" (311.98 mm)
Type	PCI Carrier	PCI FPGA Carrier for FMC
Standards		
PCIe	Lanes	x8
Configuration		
Power	PCI595	TBD W
Environmental	Temperature	Operating Temperature: -5° to 45°C
		Storage Temperature: -40° to +85°C
	Vibration	Operating 9.8 m/s ² (1.0 G), 5 to 500Hz
	Shock	30 Gs on each axis
	Relative Humidity	5 to 95 per cent, non-condensing
Front Panel	Interface	Front Panel FMC
		FPGA JTAG via micro HDMI
		FPGA RS-232 via micro USB
		CLK IN from SSMC
	LEDs	Four Status and Four User defined
Software Support	Operating System	N/A
Conformal Coating		Humiseal 1A33 Polyurethane (Optional)
		Humiseal 1B31 Acrylic (Optional)
Other		
MTBF	MIL Hand book 217-F @ TBD Hrs	
Certifications	Designed to meet FCC, CE and UL certifications where applicable	
Standards	VadaTech is certified to both the ISO9001:2000 and AS9100B:2004 standards	
Warranty	Two (2) years	

INTEGRATION SERVICES AND APPLICATION-READY PLATFORMS

VadaTech offers a full range of ATCA and μ TCA products including chassis platforms, shelf managers, AMC modules, carriers, Rear Transition Modules (RTM), Power Modules, and more. This allows customers to source complete systems from an industry-leader provider with confidence of interoperability. The company also offers integration services as well as pre-configured Application-Ready Platforms. Please contact VadaTech Sales for more information.

Trademarks and Disclaimer

The VadaTech logo is a registered trademark of VadaTech, Inc. Other registered trademarks are the property of their respective owners. AdvancedTCA™ and the AdvancedMC™ logo are trademarks of the PCI Industrial Computers Manufacturers Group. All rights reserved. Specification subject to change without notice.

PCI595 – PCIe FPGA Carrier for FMC, Virtex UltraScale™

ORDERING OPTIONS

PCI595 – 000 – 0E0 – GHJ

E = FPGA Speed

- 1 = Reserved
- 2 = High
- 3 = Highest

G = Clock Holdover Stability

- 0 = Standard (XO)
- 1 = Stratum-3 (TCXO)

H = Temperature Range

- 0 = Commercial (–5° to +45° C)
- 1 = Industrial (–20° to +60° C)

J = Conformal Coating

- 0 = None
- 1 = Humiseal 1A33 Polyurethane
- 2 = Humiseal 1B31 Acrylic

RELATED PRODUCTS



AMC595
Virtex UltraScale, FPGA Carrier



FMC223
14-bit 2.5 GSPS DAC



**FMC227 12-bit 2.6 GSPS Dual ADC,
Single DAC 14-bit 5.7 GSPS**

CONTACT US

VadaTech Corporate Office

198 N. Gibson Rd.
Henderson, NV 89014
Email: info@vadatech.com
Telephone: +1 702 896-3337
Fax: +1 702 896-0332

Asia Pacific Sales Office

7 Floor, No. 2, Wenhui Street, Neihu District,
Taipei 114, Taiwan
Email: info@vadatech.com
Telephone: +886-2-2627-7655
Fax: +886-2-2627-7792

VadaTech European Sales Office

VadaTech House, Bulls Copse Road,
Southampton, SO40 9LR
Email: info@vadatech.com
Telephone: +44 2380 016403