

PCI536

PCIe FPGA Carrier for FMC+,
Altera Arria-10 GX1150



PCI536

Key Features

- PCIe FPGA carrier for FMC+ per VITA-57
- Altera Arria-10 GX1150 in F1517 package
- Clock jitter cleaner
- 16 GB of DDR-4 (2 bank of 64-bits)
- Active cooling for FPGA and FMC
- Dual x6 dedicated private channels for intra-board communication via the back

Benefits

- Arria-10 FPGA in F1517 package
- Two Bank of 64-bit wide DDR4 memory allows larger buffer sizes while processing and queuing data to the host
- Electrical, mechanical, software, and system-level expertise in house
- Full system supply from industry leader
- AS9100 and ISO9001 certified company

AdvancedMC™



vadatech
THE POWER OF VISION



PCI536

The PCI536 is based on the Altera Arria-10™ GX1150 FPGA in F1517 package. The FPGA interfaces directly to the FMC+ DP 0-23 (single connector) and all FMC+ LA/HA/HB pairs, making it compatible with a wide range of industry standard VITA-57 modules. The PCI536 has x8 PCIe edge connector routed to the FPGA PCIe Gen3 hard IP block.

The FPGA has interface to two DDR4, 64-bit wide, with 16 GB total memory. This allows for large buffer sizes to be stored during processing as well as for queuing the data to the host.

The Module has dedicated dual x6 link that can interconnect to other modules through the back as private channels.



Block Diagram

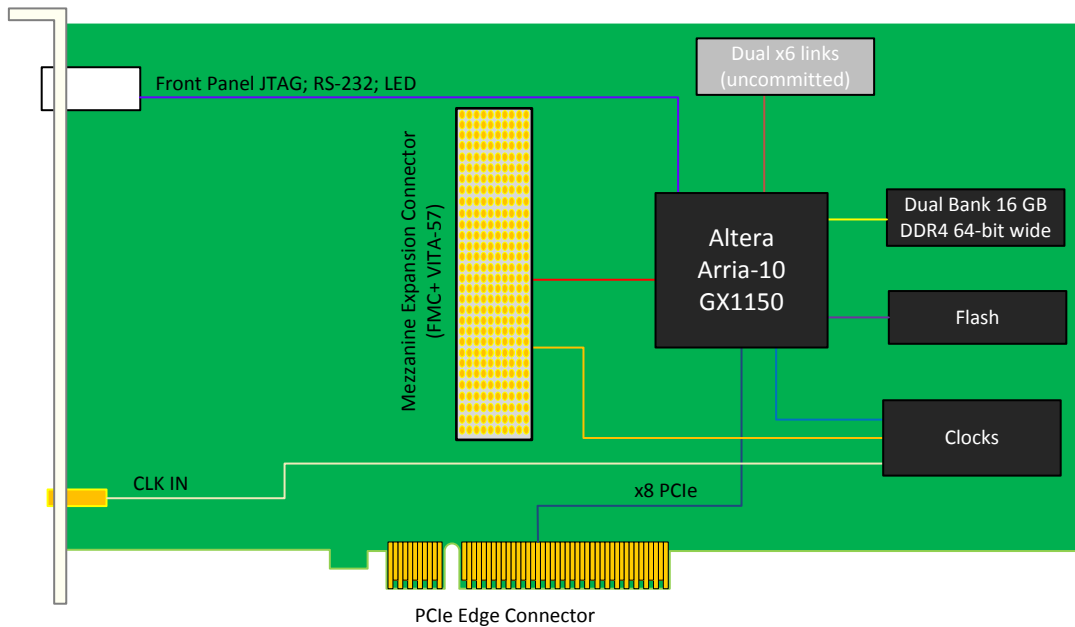

Figure 1: AMC536 Functional Block Diagram

Reference Design

VadaTech provides several Altera based FPGA products. The FPGA products are in two categories; FPGA boards with FMC carriers and FPGA products with high speed networking interfaces. The FPGA products are designed in various architectures such as AMC modules, PCIe cards and Open VPX.

VadaTech provides a reference design implementation for our FPGAs complete with VHDL source code, documentation and configuration binaries. The reference design focuses on the I/O ring of the FPGA to demonstrate low-level operation of the interconnections between the FPGA and other circuits on the board and/or backplane. It is designed to prove out the hardware for early prototyping, engineering/factory diagnostics and customer acceptance of the hardware, but it does not strive to implement a particular end application. The reference VHDL reduces customer time to develop custom applications, as the code can be easily adapted to meet customer's application requirements.

The reference design allows you to test and validate the following functionality (where supported by the hardware):

- Base and Fabric channels
- Testing ports on FMC (FMC+ carriers only)
- Clocks
- Data transfers
- Memory
- User defined LEDs

VadaTech provide reference VHDL developed using Quartus and NIOS II Software Build Tools for Eclipse (Eclipse IDE for C/C++ Version: Indigo Service Release 2) for testing basic hardware functionality. The reference VHDL is royalty free to use and modify on VadaTech products, so can be used within applications at no additional cost. However, customers are restricted from redistributing the reference code and use of this code for any other purpose (e.g. it should not be used on non-VadaTech hardware).

The reference VHDL is shipped in one or more files based on a number of ordering options. Not all ordering options have an impact on the FPGA and a new FPGA image is created for those options that have direct impact on the FPGA. Use the correct reference image to test your hardware. For more information, refer to the FPGA reference design manual for your device which can be accessed from customer support site along with the reference images.

Supported Software

- Default FPGA image stored in flash memory
- Reference application projects for other ordering options

The user may need to develop their own FPGA code or adapt VadaTech reference code to meet their application requirements. The supplied pre-compiled images make use of hardware evaluation licenses, where necessary, instead of full licenses. This is because VadaTech does not provide license for the Quartus II tool nor the IP cores from Altera, so please contact Altera where these are required.

[Quartus Design Software](#)

Compatible FMC+

VadaTech offers VITA-57 compatible FMCs providing ADC, DAC, RF transceivers and network interfaces. These FMCs are widely deployed in commercial and mil/aero form factors. Please contact VadaTech Sales for more information.

Specifications

Architecture		
Physical	Dimensions	Single module Width: 4.36" (110.74 mm) Depth 12.23" (311.98 mm)
Type	PCI Carrier	PCI FPGA Carrier for FMC+
Standards		
PCIe	Lanes	PCIe Gen3 x8
Configuration		
Power	PCI536	~30 W application dependent
Environmental	Temperature	Operating temperature: -5° to 45° C (55°C for limited time, performance restrictions may apply), industrial and extended versions also available (See environmental spec sheet) Storage Temperature: -40° to +85°C
	Vibration	Operating 9.8 m/s ² (1G), 5 to 500Hz on each axis
	Shock	Operating 30G on each axis
	Relative Humidity	5 to 95 per cent, non-condensing
Front Panel	Interface Connectors	Front panel FMC+ FPGA RS-232 via micro USB CLK IN from SSMC
	LEDs	4 user defined
Software Support	Operating System	Agnostic
Conformal Coating		Humiseal 1A33 Polyurethane (Optional) Humiseal 1B31 Acrylic (Optional)
Other		
MTBF		MIL Hand book 217-F@ TBD hrs
Certifications		Designed to meet FCC, CE and UL certifications, where applicable
Standards		VadaTech is certified to both the ISO9001:2000 and AS9100B:2004 standards
Warranty		Two (2) years

INTEGRATION SERVICES AND APPLICATION-READY PLATFORMS

VadaTech has a full ecosystem of ATCA and μ TCA products including chassis platforms, shelf managers, AMC modules, Switch and Payload Boards, Rear Transition Modules (RTM), Power Modules, and more. The company also offers integration services as well as pre-configured Application-Ready Platforms. Please contact VadaTech Sales for more information.

Ordering Options

PCI536 – 000-0E0-G0J

		G = Clock Holdover Stability 0 = Standard (XO) 1 = Stratum-3 (TCXO)
	E = FPGA Speed 1 = Highest 2 = High 3 = Reserved	
		J = Temperature Range and Coating 0 = Commercial (–5° to +55° C), No coating 1 = Commercial (–5° to +55° C), Humiseal 1A33 Polyurethane 2 = Commercial (–5° to +55° C), Humiseal 1B31 Acrylic 3 = Industrial (–20° to +70° C), No coating 4 = Industrial (–20° to +70° C), Humiseal 1A33 Polyurethane 5 = Industrial (–20° to +70° C), Humiseal 1B31 Acrylic 6 = Extended (–40° to +85° C), Humiseal 1A33 Polyurethane 7 = Extended (–40° to +85° C), Humiseal 1B31 Acrylic

Related Products

AMC536



- Single module, mid-size AMC (full-size optional)
- Altera Arria-10 GX1150 in F1517 package
- AMC Ports 4-11 are routed to FPGA per AMC.1, AMC.2 and AMC.4

FMC214

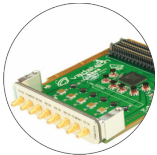

- Dual complete transceiver signal chain solution using Analog Devices AD9361 transceiver
- Frequency range 70 MHz to 6 GHz with instantaneous bandwidth from 200 kHz to 56 MHz
- MIMO transceiver is Time Domain Duplex (TDD) and Frequency Domain Duplex (FDD) compatible

FMC223



- Single module AD9739 DAC 14-bit at 2.5 GSPPS
- 2 Vpp differential Analog output swing
- Programmable DSP clock

Contact

VadaTech Corporate Office

198 N. Gibson Road, Henderson, NV 89014
Phone: +1 702 896-3337 | Fax: +1 702 896-0332

Asia Pacific Sales Office

7 Floor, No. 2, Wenhua Street, Neihu District, Taipei 114, Taiwan
Phone: +886-2-2627-7655 | Fax: +886-2-2627-7792

VadaTech European Sales Office

VadaTech House, Bulls Copse Road, Southampton, SO40 9LR
Phone: +44 2380 016403

info@vadatech.com | www.vadatech.com

Choose VadaTech

We are technology leaders

- First-to-market silicon
- Constant innovation
- Open systems expertise

We commit to our customers

- Partnerships power innovation
- Collaborative approach
- Mutual success

We deliver complexity

- Complete signal chain
- System management
- Configurable solutions

We manufacture in-house

- Agile production
- Accelerated deployment
- AS9100 accredited



vadatech
THE POWER OF VISION

Trademarks and Disclaimer

The VadaTech logo is a registered trademark of VadaTech, Inc. Other registered trademarks are the property of their respective owners. AdvancedTCA™ and the AdvancedMC™ logo are trademarks of the PCI Industrial Computers Manufacturers Group. All rights reserved. Specification subject to change without notice.

© 2017 VadaTech Incorporated, All rights reserved.
DOC NO. 4FM737-12 REV 01 | VERSION 1.1- MAR/17