

## FMC ADC, 12-bit @ 4.0 GSPS and DAC, 14-bit @ 5.7 GSPS – FMC225

FMC, High Speed ADC, DAC

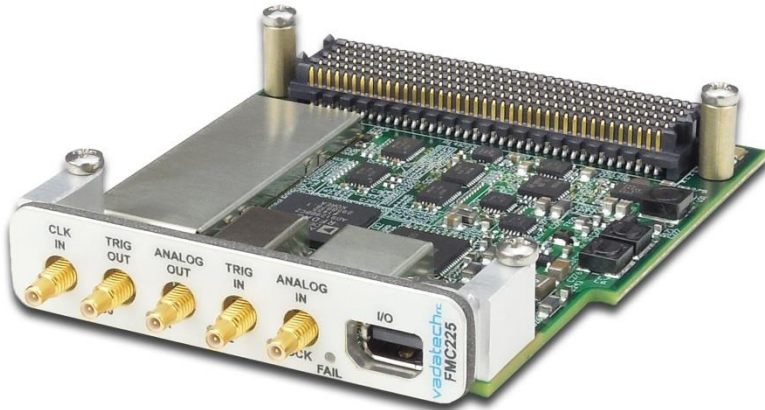

### KEY FEATURES

- FPGA Mezzanine Card (FMC) per VITA 57
- TI ADC12J4000 ADC
  - Usable output bandwidth of 800 MHz at 4x decimation and 4000 MSPS
  - Usable output bandwidth of 100 MHz at 32x decimation and 4000 MSPS
  - Bypass Mode for full Nyquist output bandwidth
- Analog Devices AD9129 DAC
  - DC-to-1.4 GHz in Baseband mode
  - DC-to-1.0 GHz in 2x Interpolation mode
  - 1.4 to 4.2 GHz in Mix-Mode
- Excellent dynamic performance
- Front panel interface includes CLK In, Trig In, Analog In/Out, and GPIO
- Ultra Low-Noise wide-band PLL
- On-chip delay locked loops (DLLs) optimize timing between different clock domains.
- RoHS compliant

### Benefits of Choosing VadaTech

- Array of FMC's and FMC carriers available from VadaTech
- High dynamic range for versatility in video/broadcast requirements
- Ideal for Broadband communications systems, Wireless infrastructure, LTE, ATE, RADAR/Jamming
- Electrical, mechanical, software, and system-level expertise in house
- Full ecosystem of front and rear boards, enclosures, specialty modules, and test/dev products from one source
- AS9100 and ISO9001 certified company

The FMC225 is an FPGA Mezzanine Module per VITA 57 specification. The FMC225 has an ADC 12-bit at 4.0 GSPS and a DAC 14-bit at 2.85 GSPS direct RF synthesis.

The FMC225 utilizes TI ADC12J4000 ADC providing 12-bit conversion at rates of up to 4.0 GSPS and an Analog Devices AD9129 DAC providing 14-bit conversion at rates of up to 2.85 GSPS. The DAC core is based on a quad-switch architecture that enables dual-edge clocking operation, effectively increasing the DAC update rate to 5.7 GSPS when configured for Mix-Mode™ or 2x interpolation. The input sampling clock can be via the front panel or the on board wide-band PLL. The FMC225 has a trigger input which is routed to the FMC connector as well as to the ADC.

The analog input/output, clock input and trigger inputs are routed via SSMC connectors.

*VadaTech can modify this product to meet special customer requirements. Contact us to discuss your application.*

## INTEGRATION SERVICES AND APPLICATION-READY PLATFORMS

VadaTech has a full ecosystem of ATCA and  $\mu$ TCA products including chassis platforms, shelf managers, AMC modules, Switch and Payload Boards, Rear Transition Modules (RTM), Power Modules, and more. The company also offers integration services as well as pre-configured Application-Ready Platforms. Please contact VadaTech Sales for more information.

## BLOCK DIAGRAM

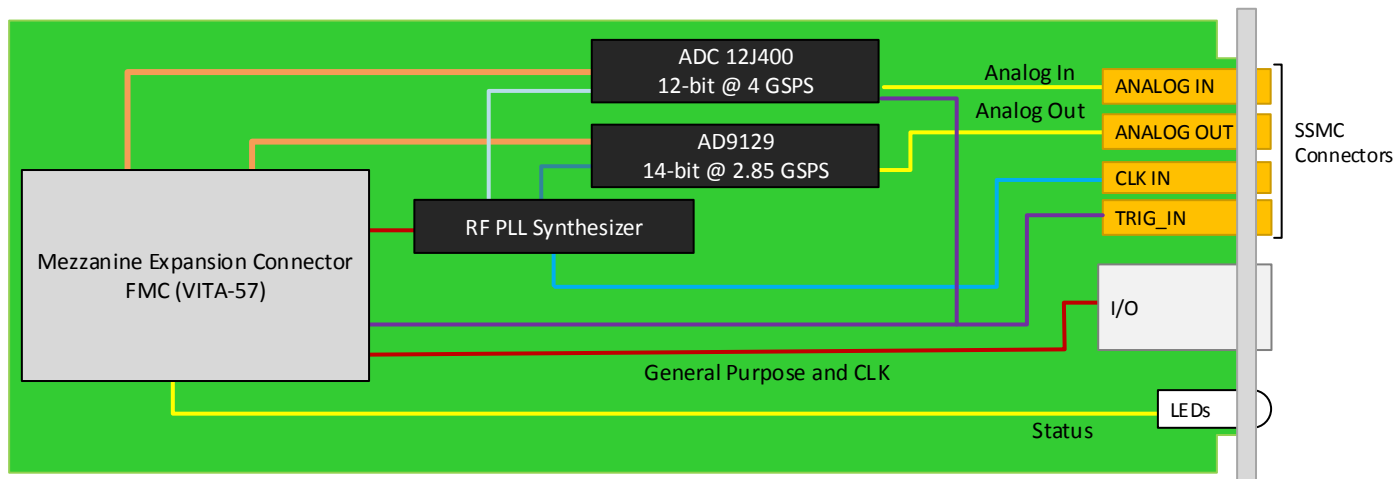

## SPECIFICATIONS

Architecture		
Physical	Dimensions	Single module
		Width 2.71" (69 mm)
		Depth 3.01" (76.5 mm)
Type	FMC	Single port ADC and single port DAC Single FMC slot
Standards		
FMC	VITA-57	ANSI/VITA 57.1-2008
Configuration		
Power	FMC225	6 W
Environmental	Temperature	Operating Temperature: -5° to 55° C (air flow requirements >400 LFM))
		Storage Temperature: -40° to +85° C
	Vibration	1G, 5 to 500 Hz on each axis
	Shock	30Gs each axis
Front Panel	Relative Humidity	5 to 95 percent, non-condensing
	Interface Connectors	SSMC and DisplayPort
	LEDs	Status
Conformal Coating		Humiseal 1A33 Polyurethane (Optional)
		Humiseal 1B31 Acrylic (Optional)
Other		
MTBF	MIL Hand book 217-F @ TBD Hrs	
Certifications	Designed to meet FCC, CE and UL certifications where applicable	
Standards	VadaTech is certified to both the ISO9001:2000 and AS9100B:2004 standards	
Warranty	Two (2) years	
Trademarks and Disclaimer	The VadaTech logo is a registered trademark of VadaTech, Inc. Other registered trademarks are the property of their respective owners. AdvancedTCA™ and the AdvancedMC™ logo are trademarks of the PCI Industrial Computers Manufacturers Group. All rights reserved. Specification subject to change without notice	

## ORDERING OPTIONS

FMC225 – 000 – 000 – 00J

### J = Conformal Coating

- 0 = Commercial (–5° to +55° C), No coating
- 1 = Commercial (–5° to +55° C), Humiseal 1A33 Polyurethane
- 2 = Commercial (–5° to +55° C), Humiseal 1B31 Acrylic
- 3 = Industrial (–20° to +70° C), No coating
- 4 = Industrial (–20° to +70° C), Humiseal 1A33 Polyurethane
- 5 = Industrial (–20° to +70° C), Humiseal 1B31 Acrylic
- 6 = Military (–40° to +85° C), Humiseal 1A33 Polyurethane\*\*
- 7 = Military (–40° to +85° C), Humiseal 1B31 Acrylic\*

\* Edge of module for conduction cooled boards

## RELATED PRODUCTS



AMC515 Virtex-7  
FPGA



AMC530 Altera  
FPGA



FMC210 ADC  
FMC

## CONTACT US

### VadaTech Corporate Office

198 N. Gibson Rd.  
Henderson, NV 89014  
Email: [info@vadatech.com](mailto:info@vadatech.com)  
Telephone: +1 702 896-3337  
Fax: +1 702 896-0332

### Asia Pacific Sales Office

7 Floor, No. 2, Wenhui Street, Neihu District,  
Taipei 114, Taiwan  
Email: [info@vadatech.com](mailto:info@vadatech.com)  
Telephone: +886-2-2627-7655  
Fax: +886-2-2627-7792

### VadaTech European Sales Office

Ocean Village Innovation Centre, Ocean Way,  
Ocean Village, Southampton, SO14 3JZ  
Email: [info@vadatech.com](mailto:info@vadatech.com)  
Telephone: +44 2380 381982  
Fax: +44 2380 381983