

KEY FEATURES

- AdvancedTCA open standard form factor
- PICMG 3.1 compliant
- Managed Layer two 10GbE and 1GbE switch
- 10GbE to the Fabric channel for 15 Node slots (option 9 or 1 selectable per port basis)
- GbE to Base Interface for 15 Node slots plus two Shelf
- Eight SFP+ cages for 10GbE ports (each port can run as GbE or 10GbE)
- Eight front panel 10/100/1000 Mbit Ethernet ports via RJ-45
- VLAN-based packet filtering
- Packet classification using IEEE802.1p QoS
- 9K Jumbo frames
- Spanning tree
- Mirroring
- QoS
- SNMP and RMON
- OS support for:
 - OS independent

The ATC807 is a low cost AdvancedTCA 26 port of 10GbE and 26 ports of one Gigabit Ethernet switch that serves a number of egress ports with support for a rich set of Layer two managed software.

The module provides 8 ports of 10GbE via the front panel, two ports to the zone three, 15 port to the Fabric Channel and one port to the update channel. The 10GbE has a GbE routed to the one GbE switch.

Further, the module provides eight GbE ports in the front via RJ-45. In addition it has 15 ports routed to the Base Channel, two ports to the Shelf Manager and one port to the update channel. One of the front panel ports is routed to the 10GbE via a mux selection to allow the 1GbE and 10GbE to interface together. In addition two of the front panel ports have a mux selection which allows routing to Zone 3.

The IPMI management is utilizing VadaTech's second generation IPMI management controller.

VadaTech can modify this product to meet special customer requirements without NRE (minimum order placement is required).

AdvancedTCA®

Low Cost 26 Port 10 GbE and GbE ATCA Switch

SPECIFICATIONS

Architecture		
Physical	Dimensions	Width: 12.687in. (322.25 mm)
		Depth: 11.024 in. (280 mm)
Type	ATCA Switch	26 Ports of GbE and 26 Ports of 10 GbE
Standards		
Processor Type	MIPS	For Management
PICMG	ATCA	PICMG 3.0 R2.0
Module Management	IPMI	IPMI Version 2.0
Configuration		
Power	ATC807	45W
Environmental	Temperature	Operating Temperature: 0° to 65° C (Air flow requirement is to be greater than 100 LFM)
		Storage Temperature: -40° to +90° C
	Vibration	1G, 5-500Hz each axis
	Shock	30Gs each axis
	Relative Humidity	5 to 95 percent, non-condensing
Front Panel	Interface Connectors	IPMI RS-232 management port
		10GbE RS-232
		1GbE RS-232
		8 RJ-45 for 10/100/1000
		8 SFP+ (can operate as 1GbE or 10GbE)
	LEDs	IPMI Management Control Link and Activity
	Mechanical	Hot Swap Ejector Handle
Software Support	Operating Systems	Independent
Other		
MTBF	MIL Handbook 217-F > TBD Hrs.	
Certifications	Designed to meet FCC, CE and UL certifications where applicable	
Standards	VadaTech is certified to both the ISO9001:2000 and AS9100B:2004 standards	
Compliance	RoHS and NEBS	
Warranty	Two (2) years.	
Trademarks and Logos	The VadaTech logo is a registered trademark of VadaTech, Inc. Other registered trademarks are the property of their respective owners. AdvancedMC™ and the AdvancedTCA™ logo are trademarks of the PCI Industrial Computers Manufacturers Group. All rights reserved. Specification subject to change without notice.	

Low Cost 26 Port 10 GbE and GbE ATCA Switch

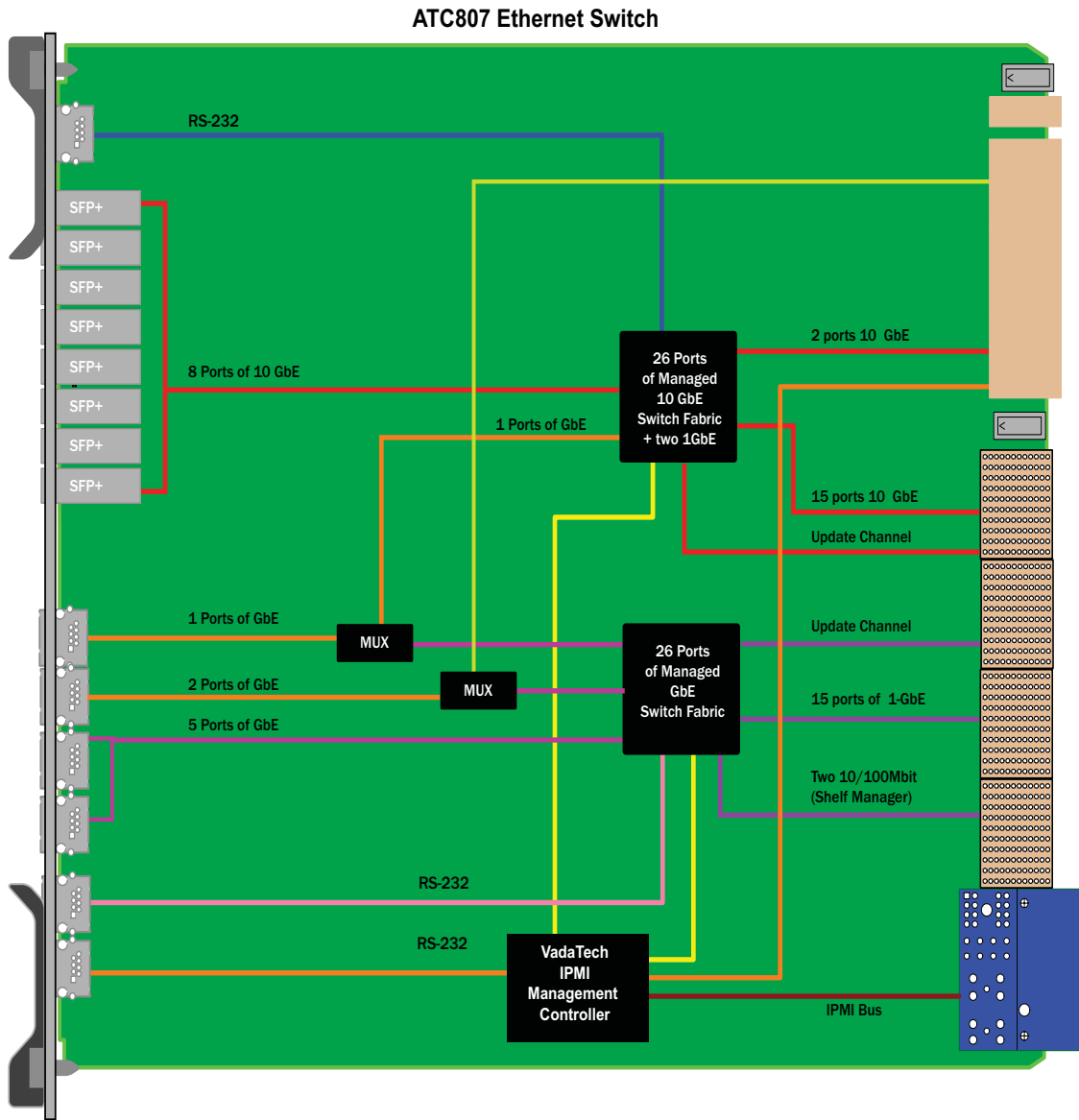

FIGURE 1. ATC807 Functional Block Diagram

Managed Layer Two 10/1GbE

Key features:

- ❖ Configuration
 - ◆ Ethernet/IEEE 802.3 Packet size (64 bytes to 1522 bytes)
 - ◆ Jumbo packets up to 9216 bytes
- ❖ L2 Switching
 - ◆ Supports up to 8K MAC address
 - ◆ Line rate switching for all packet sizes
 - ◆ Independent VLAN learning
 - ◆ VLAN flooding for broadcast and DLF packets
 - ◆ Hardware-based address learning
 - ◆ Six CPU-managed learning (CML) modes per port
 - ◆ Hardware-and-software-based aging
 - ◆ Software insertion/deletion/lookups of the L2 table
 - ◆ Same port bridging supported
 - ◆ Station movement control
- ❖ L2 Multicast
 - ◆ 4K VLANs
 - ◆ Protocol-based VLANs
 - ◆ IEEE 802.1p
 - ◆ IEEE 802.1Q
 - ◆ Independent VLAN learning (IVL)
 - ◆ Ingress filtering for IEEE 802.1Q VLAN security
 - ◆ VLAN-based packet filtering
 - ◆ MAC-based VLAN
- ❖ Source Port Filtering
 - ◆ Egress port block masks
 - ◆ Trunk group blocking masks
- ❖ Storm Control Per-Port:
 - ◆ Unknown unicast packet rate control
 - ◆ Broadcast packet rate control
 - ◆ Multicast packet rate control
- ❖ Spanning Tree:
 - ◆ IEEE 802.1D spanning tree protocol (single spanning tree per port)
 - ◆ IEEE 802.1s for multi spanning trees
 - ◆ IEEE 802.1w rapid spanning tree protocol-delete and/or replace per:
 - Port
 - VLAN
 - Port, per VLAN
 - ◆ Spanning tree protocol packets detected and sent to the CPU
- ❖ Double-Tagging:
 - ◆ Unqualified learning/forwarding
 - ◆ IEEE 802.1 Q-in-Q
- ❖ Mirroring
 - ◆ Ingress/egress mirroring support
 - ◆ Mirror-to-port receives the unmodified packet for ingress mirroring
 - ◆ Mirror-to-port receives the modified packet for egress mirroring
- ❖ Content Aware Filter Processing
 - ◆ Intelligent Protocol Aware processor with backward-compatible, byte-based classification option
 - ◆ Parses up to 128 bytes per packet
 - ◆ -512 ACL rules support
 - ◆ Multiple matches and actions per packet
 - ◆ ACL-based policing
 - ◆ Ingress/egress port based filtering
 - ◆ MAC destination address remarking
 - ◆ Traffic class definition based on the filter
 - ◆ Programmable meters allows policing of flows
 - ◆ Metering granularity from 64 Kbps to 1Gbps
 - ◆ Multiple look-ups per packet
 - ◆ Metering support on ingress ports and CPU queues
- ❖ QoS Features
 - ◆ Four CoS queues per port
 - ◆ Per-port, per CoS drop profiles
 - ◆ Port level shaping
 - ◆ Traffic shaping available on CPU queues
 - ◆ Programmable priority to CoS queue mapping
 - ◆ Provides two levels of drop precedence per queue
 - ◆ Strict Priority (SP), Weighted Round Robin (WRR), and Deficit round Robin (DRR) mechanisms for shaped queue selection
- ❖ DSCP
 - ◆ DSCP-based prioritization
 - ◆ Back pressure metering
 - ◆ DSCP to IEEE 802.1p mapping
- ❖ Port Security
 - ◆ Per port blocking
 - ◆ Supports IEEE 802.1x
 - ◆ MAC address blocking
- ❖ DoS Prevention
 - ◆ Denial of Service detection/prevention
- ❖ Management Information Base
 - ◆ SMON MIB, IETF RFC 2613
 - ◆ RMON statistics group, IETF RFC 2819
 - ◆ SNMP interface group, IETF RFC 1213, 2836
 - ◆ Ethernet-like MIB, IETF RFC 1643
 - ◆ Ethernet MIB, IEEE 802.3u
 - ◆ Bridge MIB, IETF RFC 1493

ORDERING OPTIONS

ATC807 - OBC - DEF - 00J

D = Number of Copper 1000Base-TX*

0 = None
X = Number of Transceivers

J = Conformal Coating

0 = None
1 = Humiseal 1A33 Polyurethane
2 = Humiseal 1B31 Acrylic

B = Number of Fiber 10GBase-SR*

0 = None
X = Number of Transceivers

E = Number of Fiber 1GbE SX*

0 = None
X = Number of Transceivers

C = Number of Fiber 10GBase-LR*

0 = None
X = Number of Transceivers

F = Number of Fiber 1GbE LX*

0 = None
X = Number of Transceivers

.*Total number of transceivers must not exceed 8

