

KEY FEATURES

- Supports the ATC800 GbE switch
- Eighteen SFP cages
- 18 ports of copper or fiber
- Multiple I2C busses to run the shelf
- RoHS compliant

The ART800 is a Rear Transition Module (RTM) that brings expandability to VadaTech's ATC800 switch board. The ART800 provides additional connectivity for eighteen GbE ports. The ART800 brings the Shelf Monitoring port to the rear via a Micro-DB15.

The flexibility of having SFP cages allows any combination of fiber or copper.

VadaTech can modify this product to meet special customer requirements without NRE (minimum order placement is required).

ATCA Rear Transition Module

SPECIFICATIONS

Architecture		
Physical	Dimensions	Width: 12.687in. (322.25 mm)
		Depth: 3.701 in. (94.00 mm)
Type	Rear Transition	Expansion
Configuration		
Power	ART800	Dependent on the number of SFP ports (max power with eighteen 10/100/1000 SFPs is 20W)
Environmental	Temperature	Operating Temperature: 0° to 65° C (Air flow requirement is to be greater than 200 LFM)
		Storage Temperature: -40° to +90° C
	Vibration	1G, 5-500Hz each axis
	Shock	30Gs each axis
Rear Panel	Interface Connectors	5 to 95 percent, non-condensing
		Micro-DB15 with multiple I2C busses to manage the chassis
		Eighteen SFPs
Other		
MTBF	MIL Spec 217-F > 396,000 Hrs.	
Certifications	Designed to meet FCC, CE and UL certifications where applicable	
Standards	VadaTech is certified to both the ISO9001:2000 and AS9100B:2004 standards	
Compliance	RoHS and NEBS	
Warranty	Two (2) years	
Trademarks and Logos	The VadaTech logo is a registered trademark of VadaTech, Inc. Other registered trademarks are the property of their respective owners. AdvancedTCA™ and the AdvancedMC™ logo are trademarks of the PCI Industrial Computers Manufacturers Group. All rights reserved. Specification subject to change without notice.	

ATCA Rear Transition Module

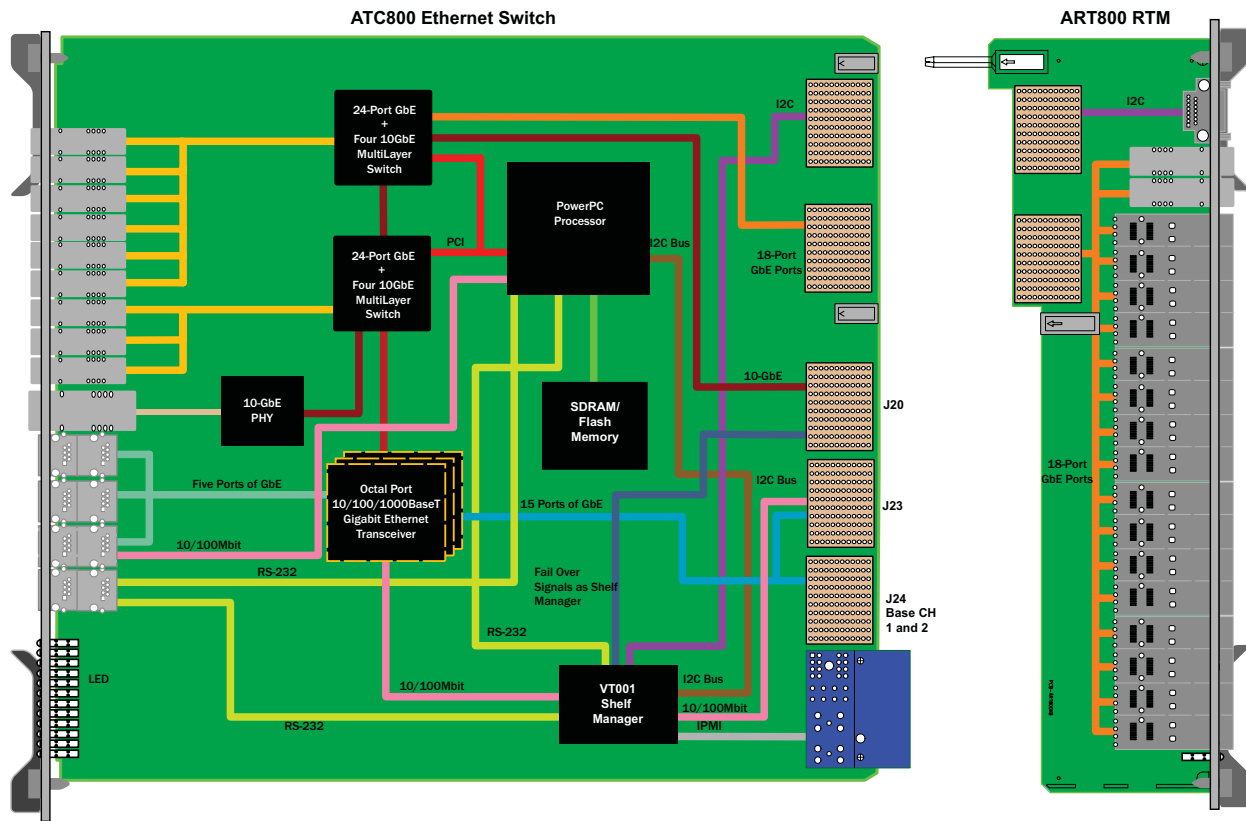

FIGURE 1. ART800 Functional Block Diagram

ORDERING OPTIONS

ART800 - AB0 - 000 - G0J

A = SFP Fiber Transceiver Type

- 0 = None
- 1 = LC/SX (850 nm)
- 2 = LC/LX (1310 nm)

B = No. of SFP Fiber Ports

- 0 = None
- 1-18 = Identifies number of fiber SFPs

G = No. of SFP Copper Ports

- 0 = None
- 1-18 = Identifies number of copper SFPs

J = Conformal Coating

- 0 = None
- 1 = Humiseal 1A33 Polyurethane
- 2 = Humiseal 1B31 Acrylic

Document No _____ Date: October 27 2007

