

KEY FEATURES

- 7-port USB hub
- Dual USB fiber ports
- 9-port managed layer two GbE switch
- Management 10/100Mbit Ethernet
- Shelf monitoring port (RS-232)
- Multiple I²C busses to interface to chassis
- RoHS compliant

The ART105 is a Rear Transition Module (RTM) that brings expandability to the VadaTech ATC109 carrier board. The nine port managed layer two switch provides four GbE 10/100/1000-BaseT ports, two GbE fiber ports and two GbE to Zone 2 of the ATC109 front board. The ART105 also provides connections for the shelf management 10/100Mbit Ethernet and RS-232 debug port. The RTM has a seven port USB hub. The USB upstream port as well as five additional downstream ports are provided via a Micro-DB25 connector. Two of the seven ports are converted from copper to fiber for long-distance USB extension.

The fiber USB ports interface with VadaTechs VT081 or VT082 products.

Multiple I2C buses are routed to the Micro-DB15 to interface with the chassis devices when the ATC109 is configured as the shelf manager.

VadaTech can modify the product to meet special customer requirements without NRE (minimum order placement is required).

Advanced TCA®

ATCA Rear Transition Module

SPECIFICATIONS

Architecture		
Physical	Dimensions	Width: 12.687in. (322.25 mm)
		Depth: 3.701 in. (94.00 mm)
Type	Rear Transition	I/O Expansion
Configuration		
Power	ART105	10W
Environmental	Temperature	Operating Temperature: 0° to 65° C (Air flow requirement is to be greater than 200 LFM)
		Storage Temperature: -40° to +90° C
	Vibration	1G, 5-500Hz each axis
	Shock	30Gs each axis
	Relative Humidity	5 to 95 percent, non-condensing
Rear Panel	Interface Connectors	25-Pin Micro D-Sub (USB upstream as well as five USB downstream ports)
		Two USB fiber ports, LC style
		Management 10/100 Ethernet RJ-45 port
		IPMI Serial RJ-45 port
		Two 1000-Base SX Ethernet (option for LX), LC style
		Four 10/100/1000 Base-TX Ethernet
	Micro-DB15 with multiple I2C busses for chassis management	
LEDs	Link and Activity	
	PCIe Lane Good	
Software Support	Operating Systems	Linux, Windows, Solaris and VxWorks
Other		
MTBF	MIL Spec 217-F > 185,000 Hrs.	
Certifications	Designed to meet FCC, CE and UL certifications where applicable	
Standards	VadaTech is certified to both the ISO9001:2000 and AS9100B:2004 standards	
Compliance	RoHS and NEBS	
Warranty	Two (2) years	
Trademarks and Logos	The VadaTech logo is a registered trademark of VadaTech, Inc. Other registered trademarks are the property of their respective owners. AdvancedTCA™ and the AdvancedMC™ logo are trademarks of the PCI Industrial Computers Manufacturers Group. All rights reserved. Specification subject to change without notice.	

ATCA Rear Transition Module

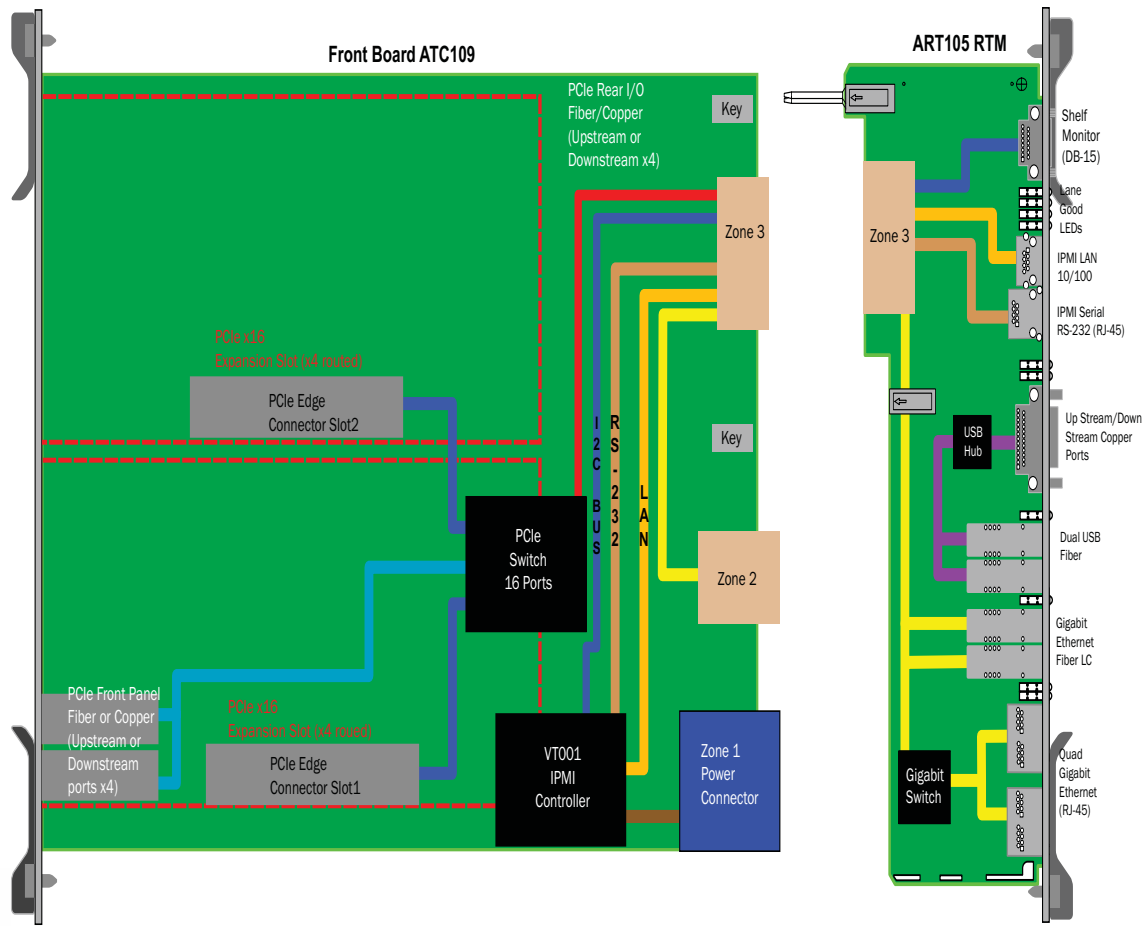

FIGURE 1. ART105 Functional Block Diagram

ORDERING OPTIONS

ART105 - A00 - 000 - 00J

A = Fiber

- 1 = LC/SX transceivers (850 nm)
- 2 = LC/LX transceivers (1310 nm)

J = Conformal Coating

- 0 = None
- 1 = Humiseal 1A33 Polyurethane
- 2 = Humiseal 1B31 Acrylic

Document No _____ Date: July 20 2007

