

XPT DUAL XEON™ SINGLE BOARD COMPUTER

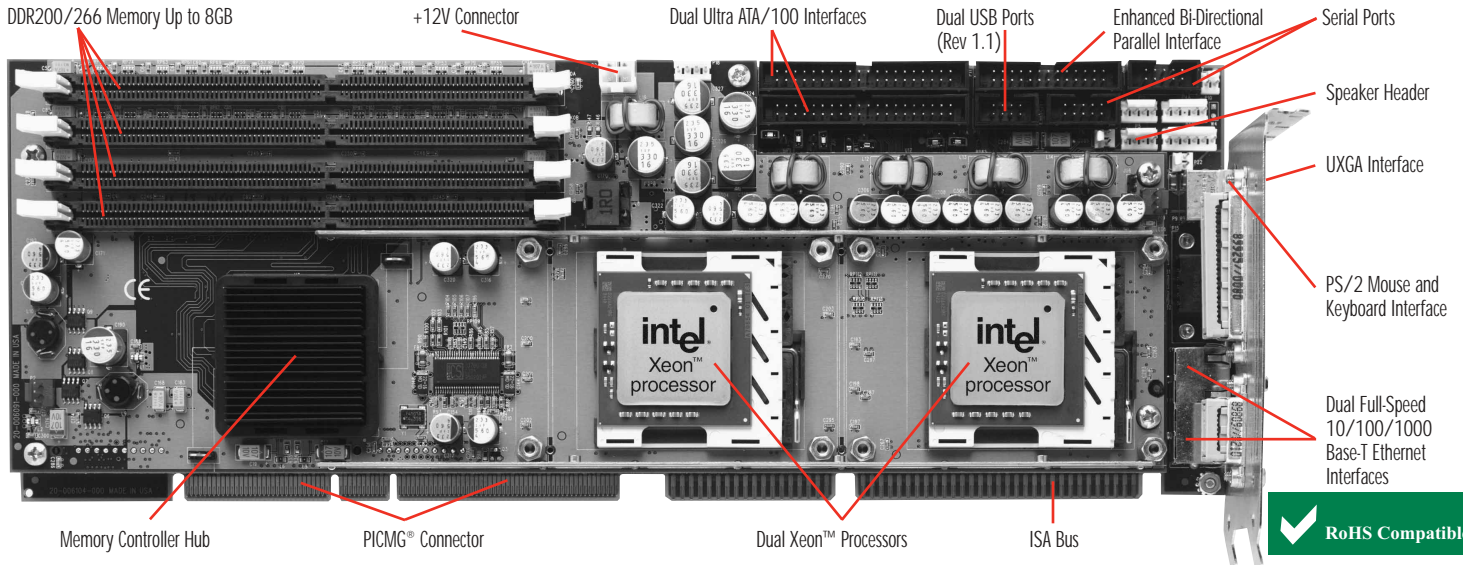

Trenton Technology's heritage of delivering innovative, applied computing solutions continues with the XPT single board computer. The XPT takes the level of processing power available in SBCs to unheard of levels. Dual Xeon™ processors, the Intel® E7501 chipset, a 533MHz system bus, dual Gigabit Ethernet ports, advanced video and I/O features make the XPT the ideal choice in applications that demand multi-processing functionality in a PICMG® form factor. Like all Trenton products, the XPT is quality built in our U. S. manufacturing facility with fast, dependable delivery schedules.

PROCESSOR:

Dual Intel™ Xeon™ processors at 2.4GHz and 2.8GHz*
Processor Package: FC-mPGA2 package (604-pin)

**Higher speeds as available*

The Xeon processors used on the XPT support a 533MHz system bus as well as Intel's NetBurst™ Micro-architecture. Both features combine to provide robust performance and fast program execution. Some of the processor features that enable such performance enhancements are:

- Hyper-Pipelined technology
- Streaming SIMD Extensions 2 (SSE2)
- Advanced Dynamic Execution
- 512K Advanced Transfer Cache (L2)
- 12K trace and data cache (L1)

Intel's Hyper-Threading technology makes a single Xeon processor appear as two logical processors. The XPT's two physical processors will function as four logical processors in applications optimized for Hyper-Threading.

E7501 CHIPSET:

The chipset supports a 533MHz system bus, DDR200/266 memory with ECC and a high-speed Hub Link 2.0 interface.

DUAL ETHERNET INTERFACES — 10/100/1000BASE-T:

The XPT has an internal PCI-X bus that connects to Intel's 82546GB Ethernet Controller chip. This board design feature provides high-speed dual Gigabit Ethernet on LAN ports 1 and 2. The XPT also supports existing 10Mb/s or 100Mb/s Ethernet networks over the same internal PCI-X bus. RJ-45 connectors located on the I/O bracket provide the mechanical interface to the Ethernet networks.

DUAL ULTRA 320 SCSI INTERFACES:

The Ultra320 SCSI interfaces use a dual-channel Adaptec SCSI controller chip. The SCSI interfaces use the SBC's internal PCI-X bus to maximize device data transfer speeds. The maximum data transfer speed is 320MB/s and up to 15 SCSI devices per interface are supported. The interfaces comply with the SPI-3 standard and are compatible with both single-ended and Low Voltage Differential (LVD) SCSI I/O. Software drivers are available for most popular operating systems. The SBC is available without the SCSI interfaces.

DDR200/266 MEMORY:

The DDR memory interface on the XPT consists of two channels, each terminating at a pair of DIMM module sockets. The XPT supports auto detection of up to 8GB of memory. The system BIOS automatically detects memory type, size and speed. The four memory sockets on the SBC must be populated in pairs, beginning with the sockets in Bank 1, and must contain ECC registered PC1600 or PC2100 DIMMS. All DIMMS must be the same speed (PC1600 or PC2100). The modules within a pair must be the same size; however, if two pairs are used, each pair can contain a different size module. The maximum memory capacity of the XPT is 8GB and the minimum interface bandwidth is 1600MB/s.

EIDE ULTRA ATA/100 INTERFACES (DUAL):

Dual high-performance PCI EIDE interfaces are capable of supporting up to two IDE disk drives each in a master/slave configuration. The interfaces support Ultra ATA/100 with synchronous ATA mode transfers up to 100MB per second.

BUS SPEEDS:

ISA	- 16-bit/8MHz
PCI	- 32-bit/33MHz, 32-bit/66MHz - 64-bit/33MHz, 64-bit/66MHz
PCI-X	- 64-bit/66MHz, 64-bit/100MHz, - 64-bit/133MHz
Hub Link 2.0	- 1GB/s
System or FSB	- 533MHz

BIOS (FLASH):

The XPT uses the AMIBIOS®. The flash BIOS resides in the 82802 Firmware Hub (FWH). AMIBIOS® contains important features such as:

- Boot from USB mass storage devices, SCSI, IDE or ATAPI
- Boot from network LAN (optional)
- Serial port console redirection to support headless operation
- PCI bus support includes 64-bit & PCI-X capability
- ATA/ATAPI support includes 48-bit LBA addressing to support ATA/IDE hard drive capacities over 137GB
- Integrated support for USB mass storage devices such as USB CD-ROM, CD-RW, etc.
- Fast POST support



Dependable, always.

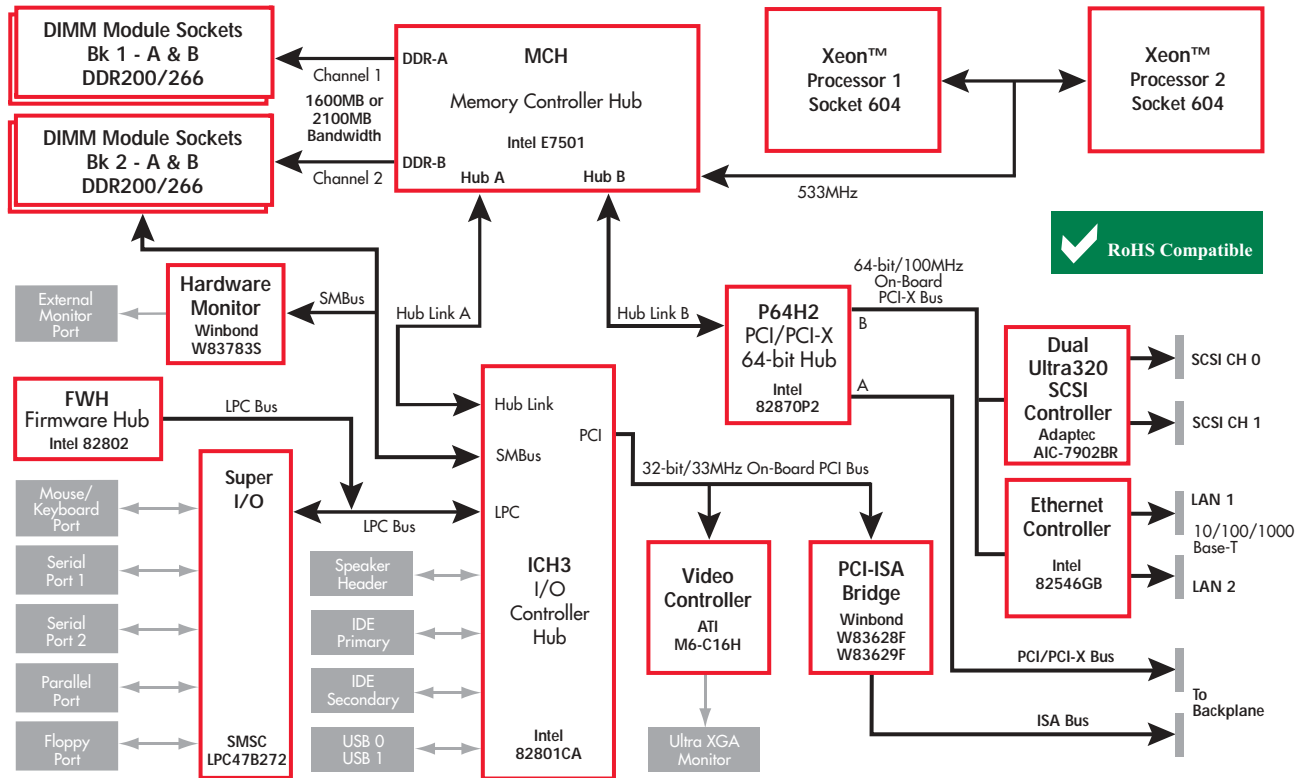

ULTRA XGA INTERFACE:

The ATI M6-16H video controller enables 2D/3D video acceleration and provides 16MB of integrated video DDR memory. The video controller supports pixel resolutions up to 1600 x 1200. Software drivers are available for most popular operating systems.

ADDITIONAL XPT FEATURES:

System Hardware Monitor:

- The Winbond W83793S chip supports hardware monitoring. The functions monitored are:
 - Voltage: +3.3V, +/-12V, +5V and VCORE
 - Fan speed
 - Temperature

Watchdog Timer:

- The programmable watchdog timer provides a system reset with a total range of 30ms to 60 seconds. The programmable increments of the watchdog are 30ms, 10s and 60s.

I/O Features:

- Two high-speed serial ports
- Enhanced bi-directional parallel interface
- Dual Universal Serial Bus (USB, Rev 1.1)
- PS/2 mouse/keyboard interface
- Floppy drive interface

STANDARDS:

- IEEE P996, Personal Computer Bus Standard
- PCI Local Bus Specification 2.1
- PICMG® 1.0 Specification
- PCI-SIG, PCI-X Addendum to the PCI Local Bus Specification Rev. 1.0b

XPT APPLICATION CONSIDERATIONS:

Power Requirements:

Typical Values	+5V*	+12V**	+3.3V*
2.8GHz	4.10A	13.15A	1.41A
2.4GHz	4.10A	9.90A	1.40A

-12V @ <100mA*
 *From backplane via PICMG® connector
 ** From ATX12V power supply or equivalent via P24 connector

The Xeon processor's power requirements created the need for an additional on-board 4-pin connector (P24). This connector requires +12V from an external power supply that conforms to the ATX12V power specification. This external power supply should have a minimum wattage rating of at least 250W. The XPT also requires that +3.3V be applied to the backplane from the power supply.

Temperature/Environment:

Operating Temperature: 0° to 45° C.
 Storage Temperature: -40° to 70° C.
 Humidity: 5% to 90% non-condensing

A Xeon processor can consume as much as 70 watts each of power on the XPT. The XPT's cooling system consists of an air duct assembly attached to the SBC, a high-reliability cooling fan mounted to the air duct intake, and passive heat sinks mounted to each processor. The fan maintains air movement over the processors' passive heat sinks and the air duct assembly directs the airflow over critical components. Warm air is exhausted from vents located on the SBC's I/O bracket.

Mechanical:

In a typical PCI/ISA backplane, the XPT's air duct design enables placement of half-size PCI cards approximately 2.3" (58.4mm) or three slots away from the SBC. Full-length cards can be placed four slots away in the backplane or approximately 3.2" (81.3mm) from the XPT.

AGENCY APPROVALS:

UL60950, CAN/CSA C22.2 No. 60950-00, EN55022:1998 Class B, EN61000-4-2:1995, EN61000-4-3:1997, EN61000-4-4:1995, EN61000-4-5:1995, EN61000-4-6:1996, EN61000-4-11:1994

ORDERING INFORMATION:

Model Name: XPT		
Model #	CPU Speed	FSB Speed
with SCSI		
6090-107-xM	2.8GHz	533MHz
6090-104-xM	2.4GHz	533MHz
without SCSI		
6090-127-xM	2.8GHz	533MHz
6090-124-xM	2.4GHz	533MHz

(xM = Memory)

Intel, Xeon and NetBurst are trademarks or registered trademarks of Intel Corporation. All other product names are trademarks of their respective owners.

Copyright ©2007 by TRENTON Technology Inc. All rights reserved.



Dependable, always.

