

T4R SINGLE BOARD COMPUTER

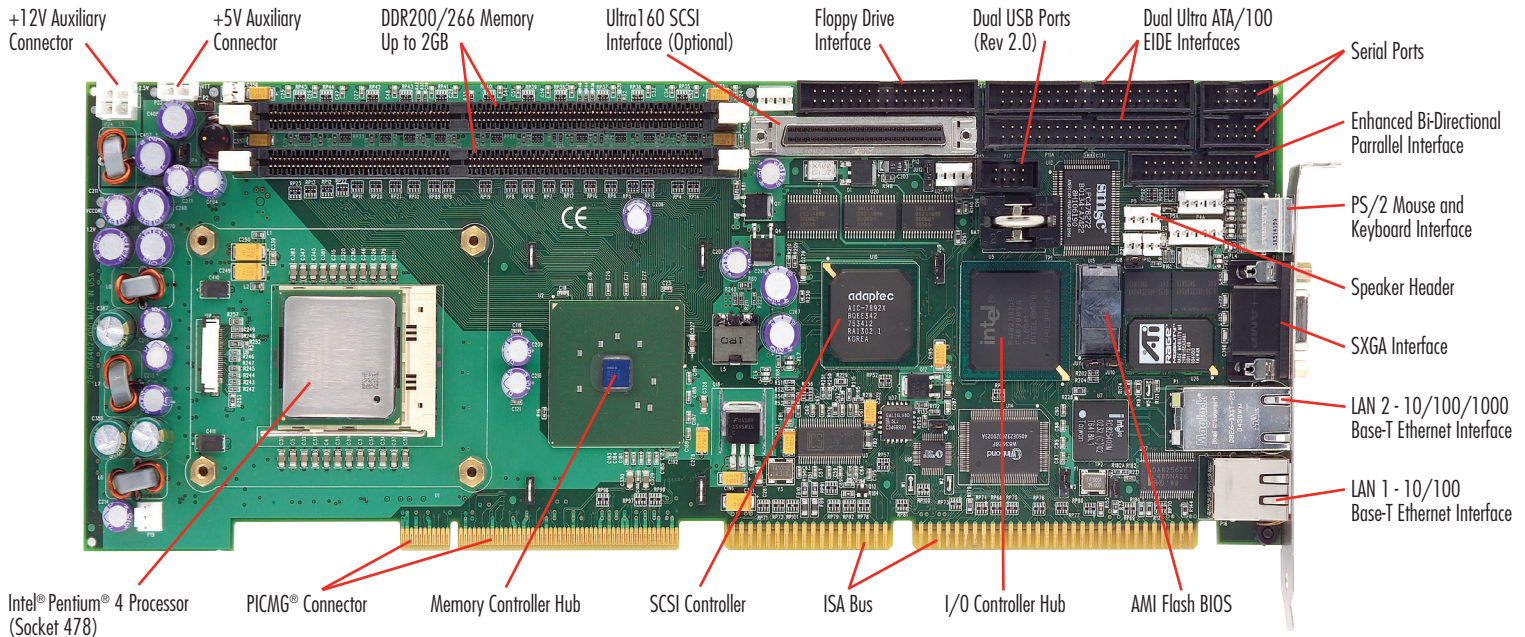

The T4R is a single board computer specifically designed to bring high-performance processing to legacy applications. The power-control circuitry on the T4R has been engineered to accommodate older backplanes and power supply harness designs. Enhanced video memory and drop-in SBC replacement capability enable cost-effective embedded computing system upgrades.

PROCESSOR:

Intel® Pentium® 4 processor at 2.4GHz and 2.8GHz
 Intel® Celeron® processor at 2.0GHz and 2.5GHz
 Processor Package: mPGA 478

The Intel® Pentium® 4 processor supports a 400/533MHz system bus as well as Intel's NetBurst™ micro-architecture. Both features combine to provide optimum system performance and fast program execution in a PCI/ISA single board computer. Some of the processor features that enable such performance enhancements are:

- Hyper-Pipelined technology
- Streaming SIMD Extensions 2 (SSE2)
- Advanced Dynamic Execution

CACHE MEMORY (L2 AND L1):

The Intel® Pentium® 4 processor supports a level two (L2) cache memory of 512K, while the L2 cache supported on the Intel® Celeron® processor is 128K. Both cache memories are integrated on-die Advanced Transfer Cache memories that are 8-way set associative and run at full processor core frequency. Both processors include a 12K level one (L1) Execution Trace Cache and an 8K L1 data cache.

CHIPSET:

The chipset supports a 400/533MHz system bus, a maximum of two double-sided DIMMs with unbuffered DDR 200/266 (PC1600/PC2100) memory with ECC and a 266 MB/s Hub Interface to the ICH4 I/O Controller.

ULTRA160 SCSI INTERFACE (OPTIONAL):

The Ultra160 SCSI interface uses an Adaptec AIC-7892 SCSI controller chip and supports SCSI device data transfer operations up to 160MB/s. The interface supports up to 15 SCSI devices, complies with the SPI-3 standard and is compatible with both single-ended and Low Voltage Differential (LVD) SCSI I/O. Software drivers are available for most popular operating systems.

DUAL ETHERNET INTERFACES:

LAN 1 provides a 10/100Base-T Ethernet interface using the Intel® 82562ET Platform LAN Connect device and the ICH4 I/O Controller Hub. The 82562/ICH4 combination provides high-speed data transfers while offloading communication tasks from the system processor. LAN 2 supports both 10/100Base-T and Gigabit Ethernet interfaces via the Intel® 82540 controller.

EIDE ULTRA ATA/100 INTERFACE (DUAL):

Dual high performance PCI Bus Master EIDE interfaces are capable of supporting up to two IDE disk drives each in a master/slave configuration. Supports Ultra ATA/100 with synchronous ATA mode transfers up to 100MB per second.

DDR200/266 MEMORY:

The DDR200/266 interface is a single-channel interface coming off the Memory Controller hub and terminating at two DIMM module sockets. The DIMM sockets can be independently populated with either PC1600 or PC2100 unbuffered memory modules with ECC. The memory interface supports auto detection of memory up to 2GB. Depending on the processor's system bus speed and the type of memory module used, the memory interface bandwidth is either 1600MB/s or 2100MB/s.

SUPER XGA INTERFACE:

The ATI Rage™ Mobility™ M1 video controller has 8MB of on-chip memory and supports up to 1280 x 1024 pixel resolutions. Software drivers are available for most popular operating systems.

BUS SPEEDS:

ISA	- 16-bit/8MHz
PCI	- 32-bit/33MHz
Hub Interface	- 266MB/s
System or FSB	- 400MHz/533MHz

BIOS (FLASH):

The T4R uses AMIBIOS®. The flash BIOS resides in the Intel® 82802 Firmware Hub (FWH). AMIBIOS8 contains useful features such as:

- CMOS setup for system parameters
- Peripheral management for configuring on-board peripherals
- PCI-to-PCI bridge support and PCI interrupt steering
- Support for flash devices for BIOS upgrading via floppy interface

Some of the other AMIBIOS8 features supported on the T4R include:

- Integrated support for USB mass storage devices such as USB CD-ROM, CD-RW, etc.
- Faster POST execution
- Improved BIOS code modularity which streamlines the BIOS customization process while offering a higher degree of BIOS customization.



Dependable, always.

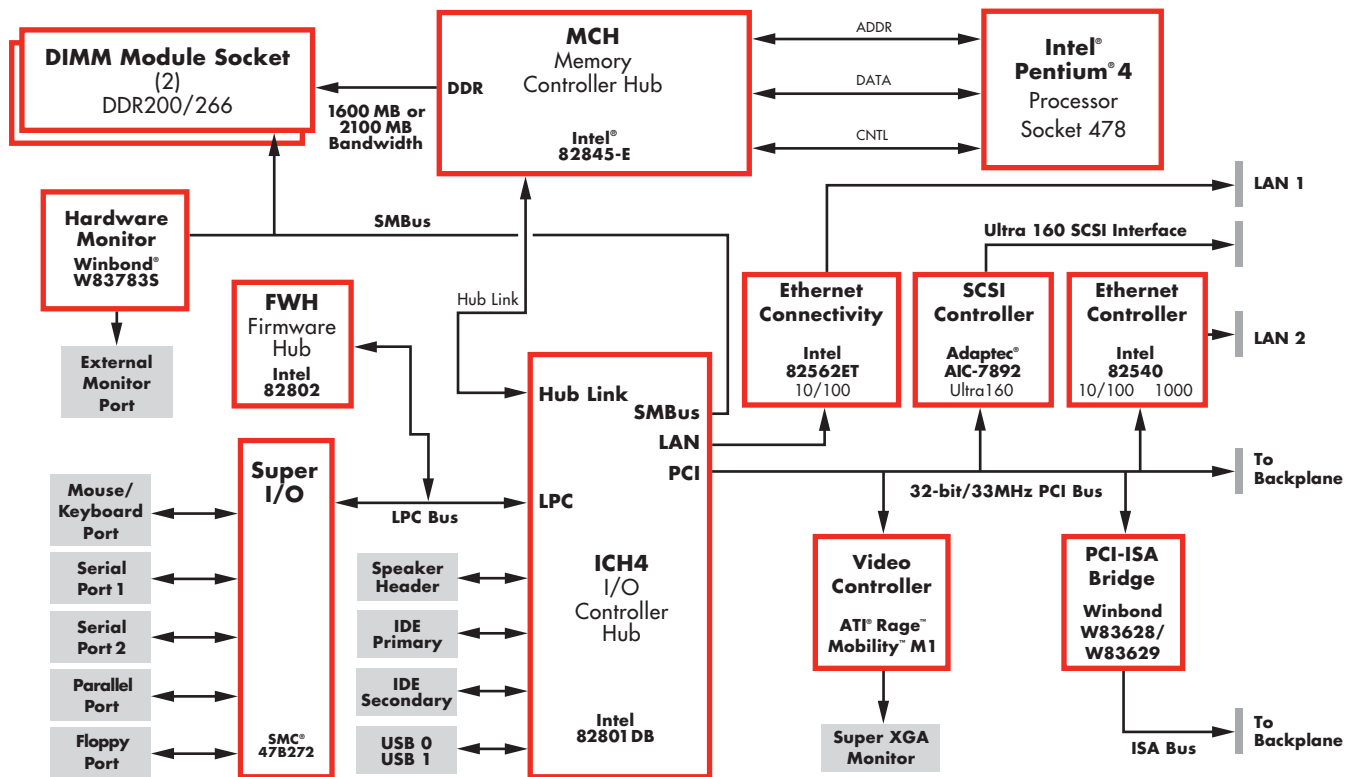

ADDITIONAL T4R FEATURES:

System Hardware Monitor:

- The Winbond W83783S chip supports hardware monitoring. The functions monitored are:
 - Voltage: +/-12V, +5V and VCore
 - Fan Speed
 - Temperature

Watchdog Timer:

- The programmable watchdog timer provides a system reset with a total range of 30ms to 60 seconds. The programmable increments of the watchdog are 30ms, 10s and 60s.

I/O Features:

- Two high-speed serial ports
- Enhanced Bi-Directional parallel interface
- Dual Universal Serial Bus (USB, Rev. 2.0)
- PS/2 mouse/keyboard interface
- Floppy drive interface

Temperature/Environment:

- Operating Temperature: 0° to 45° C.
- Storage Temperature: -40° to 70° C.
- Humidity: 5% to 90% non-condensing
- The T4R's cooling system uses a high-reliability fan mounted to the SBC.

STANDARDS:

- IEEE996, Personal Computer Bus Standard
- PCI Local Bus Specification 2.1
- PICMG 1.0 Specification
- Ultra160 SCSI, SPI-3 Standard

T4R APPLICATION CONSIDERATIONS:

Power Requirements:

Typical Values

Intel® Pentium® 4:	CPU	+5V*	+12V	+3.3V
*+5V only	2.8GHz	12.2A	0.5A	None
operation	2.4GHz	11.9A	0.5A	None
Intel® Celeron®:	2.5GHz	11.7A	0.5A	None

Intel® Pentium® 4:	CPU	+5V*	+12V*	+3.3V
*+5 and+12V	2.8GHz	2.5A	4.9A	None
operation	2.4GHz	2.5A	4.5A	None
Intel® Celeron®:	2.5GHz	2.5A	4.4A	None

Power Control Circuitry:

Generating +3.3V on board makes the T4R an ideal SBC choice for upgrading embedded computing systems. Trenton offers a +5V auxiliary connector jumper cable for use on the SBC. This cable allows the +5V from the +5V auxiliary connector to be routed over to the +12V auxiliary connector to provide sufficient power for Intel® Pentium® 4 processors with clock speeds of 2.8GHz or less. The +12V auxiliary power connector can also be used to provide additional power from the system power supply and must be used when using processors with clock speeds over 2.8GHz.

Mechanical:

Overall dimensions for the T4R, including the active cooling system, are 13.3" L (338mm) x 4.8" H (121.9mm) x 1.65" W (41.9mm).

AGENCY APPROVALS:

UL60950, CAN/CSA C22.2 No. 60950-00, EN55022:1998 Class B, EN61000-4-2:1995, EN61000-4-3:1997, EN61000-4-4:1995, EN61000-4-5:1995, EN61000-4-6:1996, EN61000-4-11:1994

ORDERING INFORMATION:

Model #	Model Name: T4R	SCSI Option
	CPU Speed	
	Intel® Pentium® 4	
6401-107-xM	2.8GHz	Yes
6401-104-xM	2.4GHz	Yes
6401-127-xM	2.8GHz	No
6401-124-xM	2.4GHz	No
	Intel® Celeron®	
6401-507-xM	2.5GHz	Yes
6401-502-xM	2.0GHz	Yes
6401-527-xM	2.5GHz	No
6401-522-xM	2.0GHz	No

Intel, Pentium and NetBurst are trademarks or registered trademarks of Intel Corporation. All other product names are trademarks of their respective owners.

Copyright ©2005 by TRENTON Technology Inc. All rights reserved.



Dependable, always.