

### FEATURES

- Small Form Factor (SFF) backplane supports one PICMG® 1.3 server-class system host board
- Four PCI Express® option card slots
- PCIe card slot configurations: two PCIe x16 mechanical / x8 electrical and two PCIe x8 mechanical / x4 electrical\*
- Optimized for use with Trenton high-performance PICMG 1.3 system host boards
- Two 10/100/1000Base-T backplane Ethernet ports\*\*
- Four USB 2.0 backplane I/O connections\*\*
- ATX/EPS, +12V AUX vertical and right-angle input power connector configuration options
- Five-year factory warranty
- Made in U. S. A.

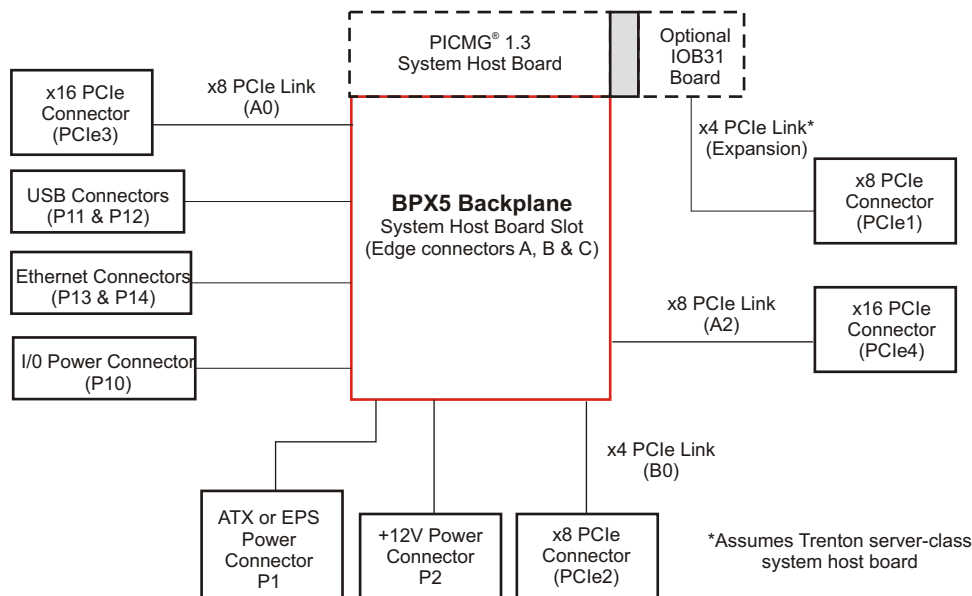

### BLOCK DIAGRAM:



### SMALL FORM FACTOR PCI EXPRESS BACKPLANE:

The PCI Express® link design of the Trenton BPX5 backplane supports PICMG® 1.3 server-class SHBs. On this PCI Express-only backplane, all of the option card slots are connected directly to the system host board ensuring maximum possible PCIe data throughput speeds. Card slots PCIe3 and PCIe4 are x16 mechanical slots that are both connected directly to the SHB and driven with x8 PCIe electrical links. PCIe1 and PCIe2 are x8 mechanical slots and PCIe2 is driven with a x4 PCIe link directly from the SHB. The PCIe1 slot is driven by a x4 electrical link delivered to the card slot via an IOB31 module installed on the SHB.

### APPLICATION EXAMPLES:

A system design that needs to support multiple PCI Express option cards on a small form factor backplane that can fit inside tight locations within data gathering, diagnostic, mechanical assembly or inspection machines are typical applications for the Trenton BPX5 backplane. The BPX5 backplane design provides several direct PCI Express serial interface connections from the COTS option cards to the system host board. These direct and high-speed PCIe card interconnects ensure that the system's option cards are taking full advantage of the inherent speed and bandwidth capabilities of the PCI Express data links.

### BACKPLANE MODEL: BPX5

MODEL#	MODEL NAME	DESCRIPTION
6510-007	BPX5-CRA	Right-angle ATX/EPS and +12V AUX connectors
6510-008	BPX5-CST	Vertical ATX/EPS and +12V AUX connectors

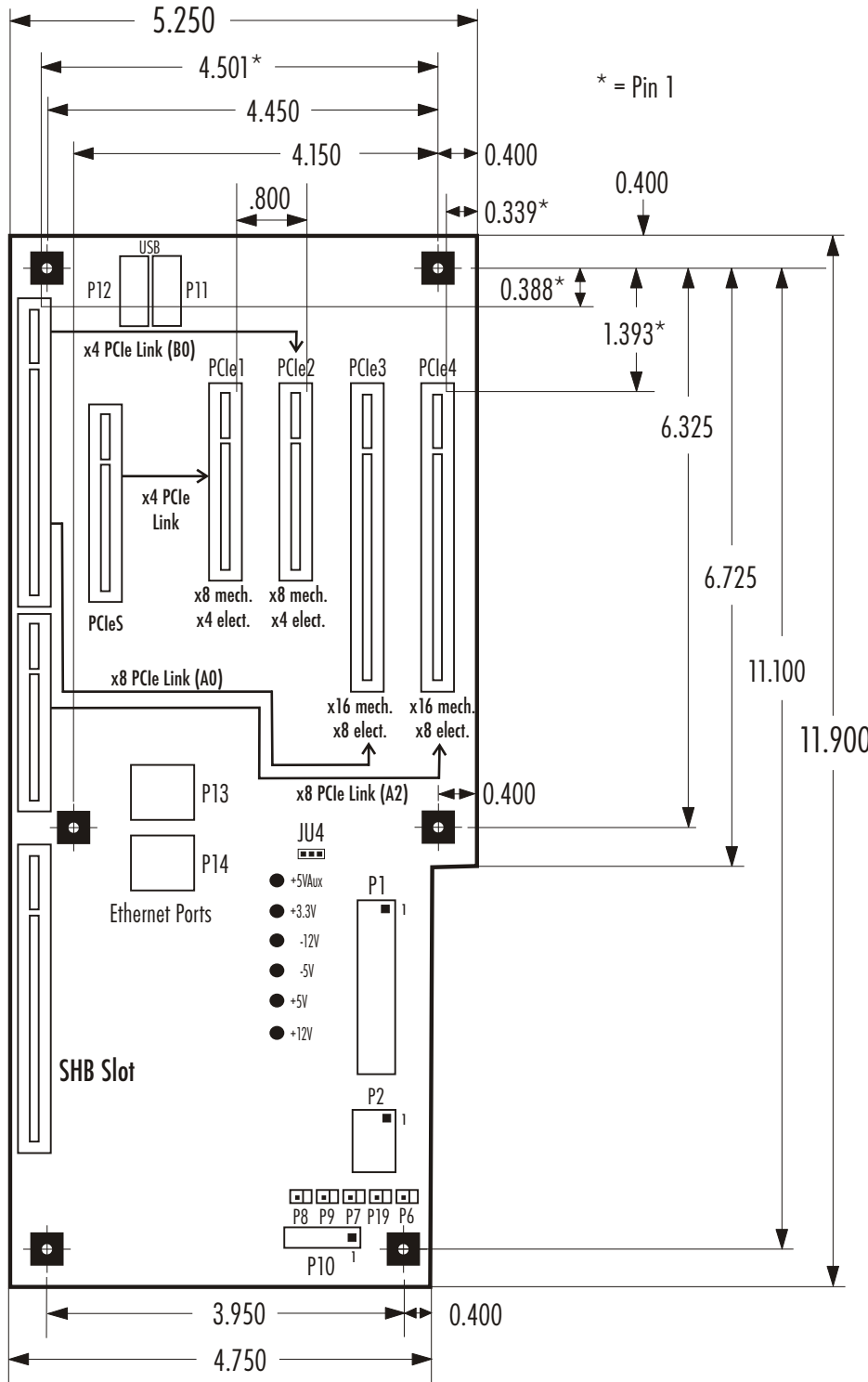

**SUGGESTED TRENTON SERVER CLASS**

**PICMG 1.3 SHBs:**

**DUAL PROCESSOR SYSTEM**

**HOST BOARDS**

JXT6966	MCXT	MCXT-E	SLT
---------	------	--------	-----

**SINGLE PROCESSOR SYSTEM HOST**

**BOARDS**

TSB7053	JXTS6966	MCXI	SLI
---------	----------	------	-----

**ENVIRONMENTAL SPECIFICATIONS:#**

Operating Temp.: 0° C. to 60° C

Storage Temp.: -20° C. to 70° C

Humidity: 5% to 90%, non-condensing

#Environmental specifications for system host boards / single board computers are usually lower than those of the backplane. Check with your SHB/SBC vendor.

The Trenton BPX5 is a lead-free, RoHS compliant backplane.

This backplane is designed to meet worldwide EMI emissions requirements, CE conformity and immunity standards. Contact Trenton for specific standard numbers.

The Trenton BPX5 backplane is designed for UL60950 and CAN/CSA C22.2 No. 60950-00.

**Engineering Notes:**

All power connectors are shown in the layout drawings. The connectors are populated based on model.

Nominal PCB thickness: 0.062"

Connector spacing: .800" centers

To find the center of a PCI Express option card connector and the SHB slot add 0.049" to the pin 1 location dimension.

Mounting holes: 0.156" diameter

All dimensions are inches.

\*PCIe1 slot functionality requires an IOB31 installed on the SHB

\*\* Optional USB and Ethernet connectivity provided by the PICMG 1.3 System Host Board. Not all SHBs support this capability.

*Product Photo Note: The photo of the 6510 backplane shown on page one is a provided for illustrative purposes only. Actual connector locations are illustrated in the backplane layout drawings and on the Trenton website.*

PICMG is a registered trademark of the PCI Industrial Computer Manufacturers Group. All other product names are trademarks of their respective owners.

Copyright ©2012 by TRENTON Technology Inc.  
All rights reserved

