

ioLogik 4000 Series Expandable Remote I/O Servers

Expandable Remote I/O Solutions for Data Acquisition and Control

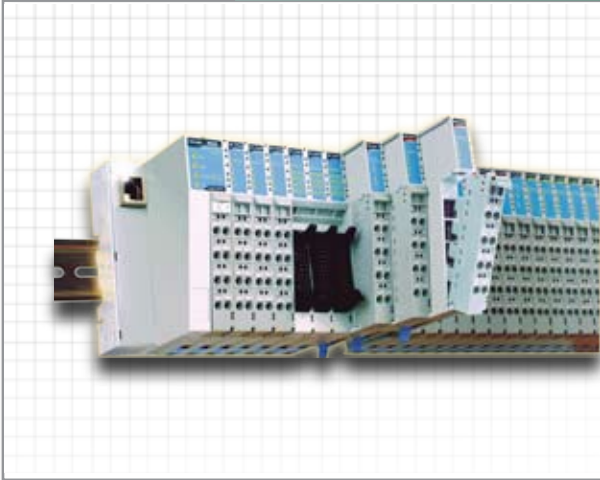

Features

- Remotely acquire sensor data and control I/O points via Ethernet, RS-485, and RS-232
- Full range of digital and analog I/O modules
- Expandable up to 32 modules for a maximum of 512 DI/O points or 124 analog channels
- Modular package for fast swap and maintenance
- Standard Modbus/TCP/RTU/ASCII, and compatible with most SCADA software
- Easy-to-use DLL library for easy user programming



Overview

The ioLogik 4000 series of remote I/O servers is designed to read sensor data, on/off status, and to control the on/off status of devices via Ethernet or RS-485/232 remotely from a host computer or a PLC controller. Support for the standard

Modbus protocol makes ioLogik 4000 compatible with most SCADA software, such as Intellution iFix, Wonderware, and Labview.

Link the Real World and Digital World

ioLogik Remote I/O from MOXA connects a variety of sensors, and electrical, electronic, and mechanical devices—temperature, humidity, and light sensors, pressure transmitters and motors, serial devices, and more—to computers and applications over standard Ethernet networks

and the Internet. Moxa also offers a traditional RS-485 model of remote I/O server that can work with existing applications. By using an NPort Wireless Device Server, you can even connect sensors and devices via a Wireless LAN network.



Expandable I/O Modules for a Full Range of I/O Combinations

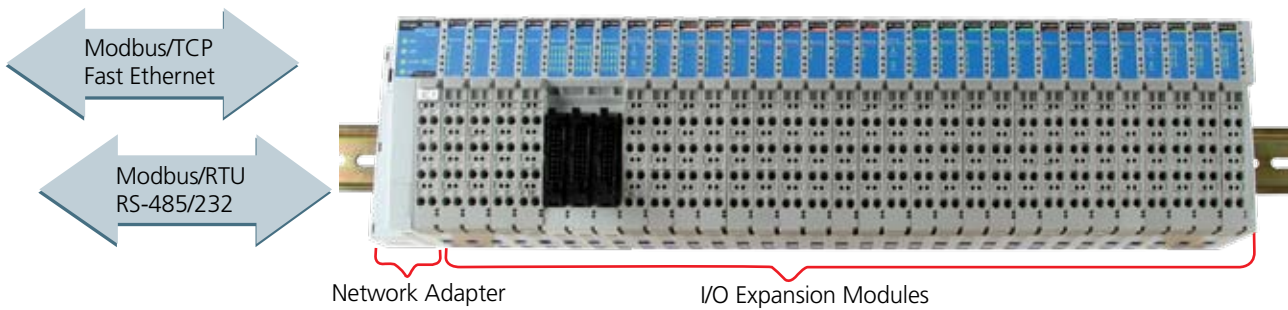

Types of Network Adapter		
Ethernet	RS-485	RS-232

I/O Module							
Digital Input		Digital Output		Analog Input		Analog Output	
Type	Channels	Type	Channels	Type	Channels	Types	Channels
24 VDC	4, 8, 16	24 VDC	4, 8, 16	0 to 20 mA	4	0 to 20 mA	2
48 VDC	4	24 VDC w/ Diag	4	4 to 20 mA	4	4 to 20 mA	2
110 VAC	4	125 VAC	2	0 to 10V	4	0 to 10V	2
230 VAC	4	230 VAC	2	+/-10V	4	+/-10V	2
				0 to 5V	4	0 to 5V	2
				RTD	2		
				TC	2		

Easy-to-Use Windows Utility

ioAdmin is designed to configure and monitor ioLogik servers remotely. ioAdmin automatically detects the installed Ethernet I/O server and presents the installation sequence of the I/O expansion modules. ioAdmin also detects and generates a Modbus Address table, which can be printed or stored on a computer for SCADA software configuration.

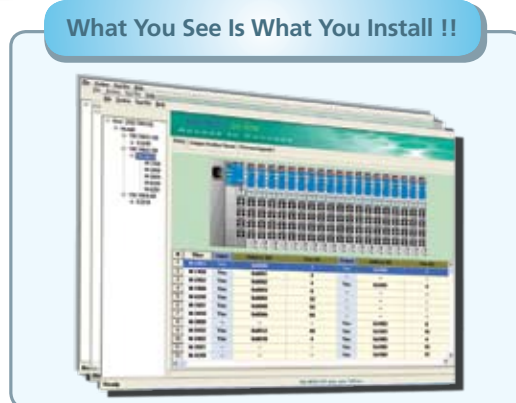

Easy maintenance

ioLogik 4000 servers provide sprint type, removable terminal blocks (RTB) that allow you to preserve field wiring before replacing any I/O expansion modules. Each I/O expansion module can be quickly and easily replaced.



Slice Type I/O Modules

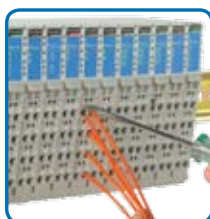

Removable Terminal Block



Spring Type Terminal Block



Module Coding Tag

Automatic search for installed ioLogik servers

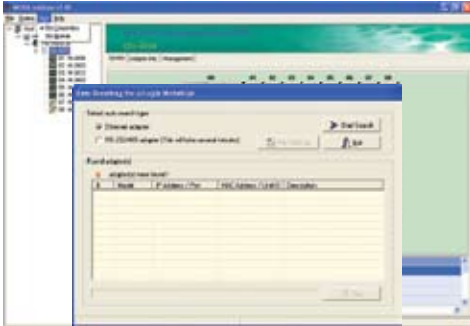

ioAdmin can automatically search for installed ioLogik servers. The automatic search function supports both Ethernet and RS-232/485 searching.

Online Documentation

Traditionally, engineers needed to manually prepare a wiring handbook. ioAdmin provides convenient online documentation that engineers may use when planning or troubleshooting field wiring. The online documentation not only covers module types, but also includes a wiring guide. The search by keyword function gives engineers a more efficient means of reducing overall installation time.

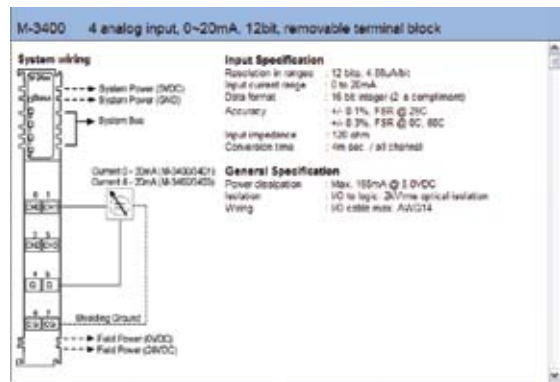

Report Generation

To help you record I/O module combinations and parameters, ioAdmin can generate a report file in text format that may be used to help manage the system. There are three areas in the report. One is for slice models, another is for slice configurations, and the third is for the Modbus address table. To help you configure SCADA, you can see the combination of slices in the slice models and the Modbus address in the Modbus address table. This is particularly helpful since the Modbus address is dynamically dependent on the combination of slices.

```

2. Slice configurations
00  H0-H010 IP=140.136.15.100,MS-255.255.0,GA-140.136.15.254,MC-10-00-00-10-00-00
    Matching-Disable
01  H-1000  -n/a-
02  H-2402  -n/a-
02  H-2402  Ch00: Safe mode-Safe Status(OFF)
02  H-2402  Ch01: Safe mode-Safe Status(OFF)
02  H-2402  Ch02: Safe mode-Safe Status(OFF)
02  H-2402  Ch03: Safe mode-Safe Status(OFF)
03  H-4211  Ch01: Safe mode-Safe Value(0x0000)
03  H-4211  Ch02: Safe mode-Safe Value(0x0000)
04  H-3412  -n/a-
05  H-5200  Ch00: Sensor Type=PT100, Temperature Type=Celsius (°C), Filter Type=Normal
05  H-5200  Ch01: Sensor Type=PT100, Temperature Type=Celsius (°C), Filter Type=Normal

3. Modbus address table
Slot No.   Channel No.  I/O Type  Modbus Address(MOD)  Modbus Address(BIT)  I/O Data Length(bits)
01         01           Input    0x0000/0x01         0x0001                0x0001
01         02           Input    0x0000/0x02         0x0002                0x0001
01         03           Input    0x0000/0x03         0x0003                0x0001
01         04           Input    0x0000/0x04         0x0004                0x0001
    
```

← Slice configuration

← Modbus address table

Remote Configuration

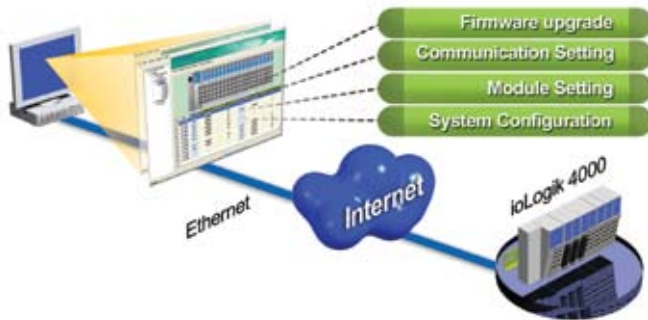

ioAdmin is a powerful, Windows-based configuration and management tool. You may use ioAdmin to modify the IP address, update communication parameters, and configure all other settings easily. In addition, ioAdmin can be used to configure ioLogik I/O servers from a remote host. This means that ioLogik servers may be configured from anywhere over the Ethernet, which may help reduce operating costs.

I/O Testing

ioAdmin provides a test function to verify reliable operation of digital and analog output channels. Traditionally, users needed to use a meter to check the status of each sensor. With ioLogik servers, they may use ioAdmin's intuitive software interface to test digital and analog output channels.

Digital output: Use the switch to test the on/off status.

Analog output: Use the slider to test the voltage output.

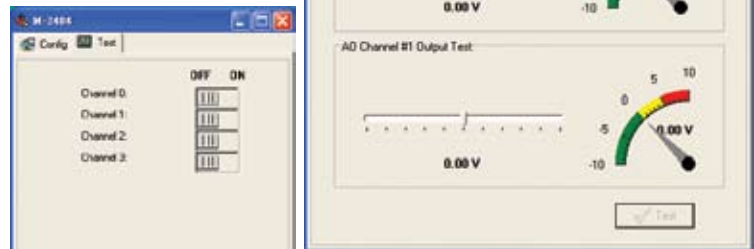

Safe Status with Communication Watchdog Timer

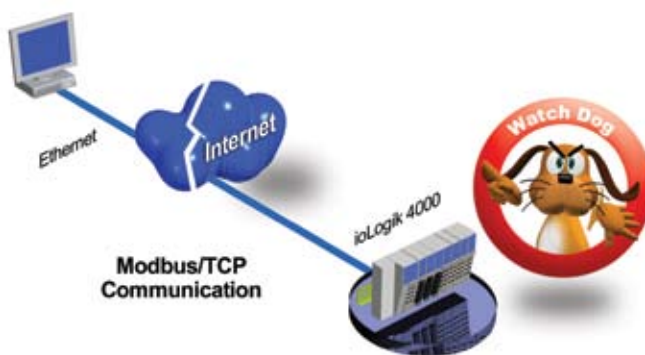

ioLogik 4000 servers are equipped with a built-in watchdog timer that monitors the Modbus communication status. If Modbus communication between the remote I/O server and a host computer or a PLC is interrupted for a user-defined period of time, the watchdog can activate safe status to reset all output channels to a user-defined state. The watchdog ensures the safety of field operations when communication is a problem.

Digital output channels may be set to On, Off, or Hold Last Status when safe status is activated. Analog

output channels may be set to Fixed Safe Value, Low Limit, or High Limit when safe status is activated. For example, if you pre-define the safe status of the DO to "off," when the Modbus communication times out, the safe status will change the DO status to "off."

Self-Diagnostic Function for Digital Output Channels

The M-2402/2403/2404/2405 modules provide a self-diagnostic function to guarantee that the digital output signal is monitored electronically. The hardware-monitored status will write back to the logic system. After the software sends a command to the above I/O models, you will get the actual digital out status over the network. This is all done internally; configuration is not required.

Check Remote I/O Status with a Web Browser



ioAdmin is the main configuration interface for ioLogik servers. However, you can also check some information using the ioLogik server's web console. The following information can be obtained using your web browser:

- Network configuration
- Expansion module
- Status of each channel

Versatile Software Support

ioLogik 4000 servers support the standard Modbus protocol and is compatible with most SCADA software. In addition, MOXA provides an easy-to-use MXIO DLL library that helps programmers develop application software with Visual Basic or C language under a Windows platform.

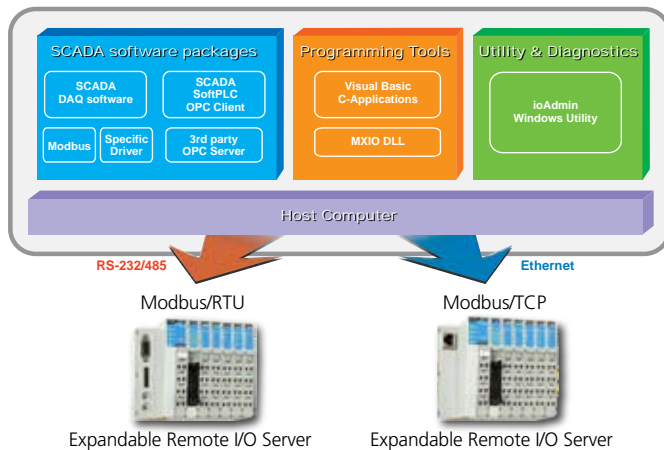

Supports Various SCADA Software Packages



The ioLogik 4000 line was designed using the standard Modbus protocol and can be used with most SCADA systems. The following SCADA software was found to be compatible with ioLogik 4000 servers: Modicon Driver, Wonderware Intouch, GE Fanuc iFIX and CIMPLICITY, Broadwin,kingview, and Citect. In addition, we successfully tested OPC Server "Kepware," which means that ioLogik 4000 servers may be accessed using SCADA or OPC Server. (Note: You can download the installation guide for different SCADA software packages from Moxa's download center)

Dimensions

I/O Terminal Dimensions

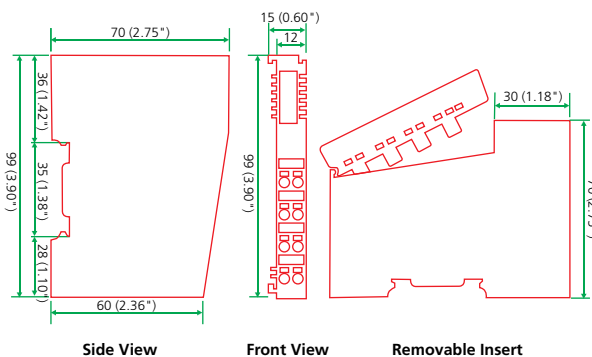

I/O Network Adaptor Dimensions

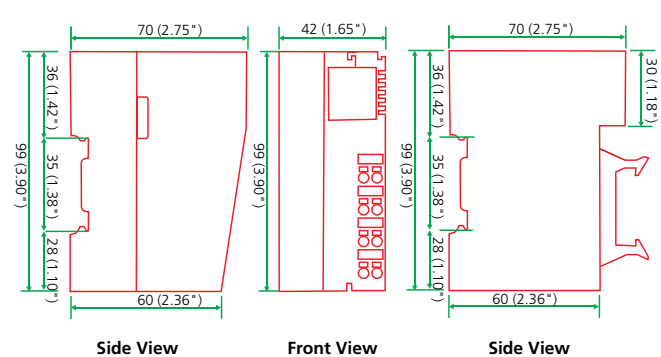

Network Adapter Modules

NA-4010 Ethernet Network Adapter

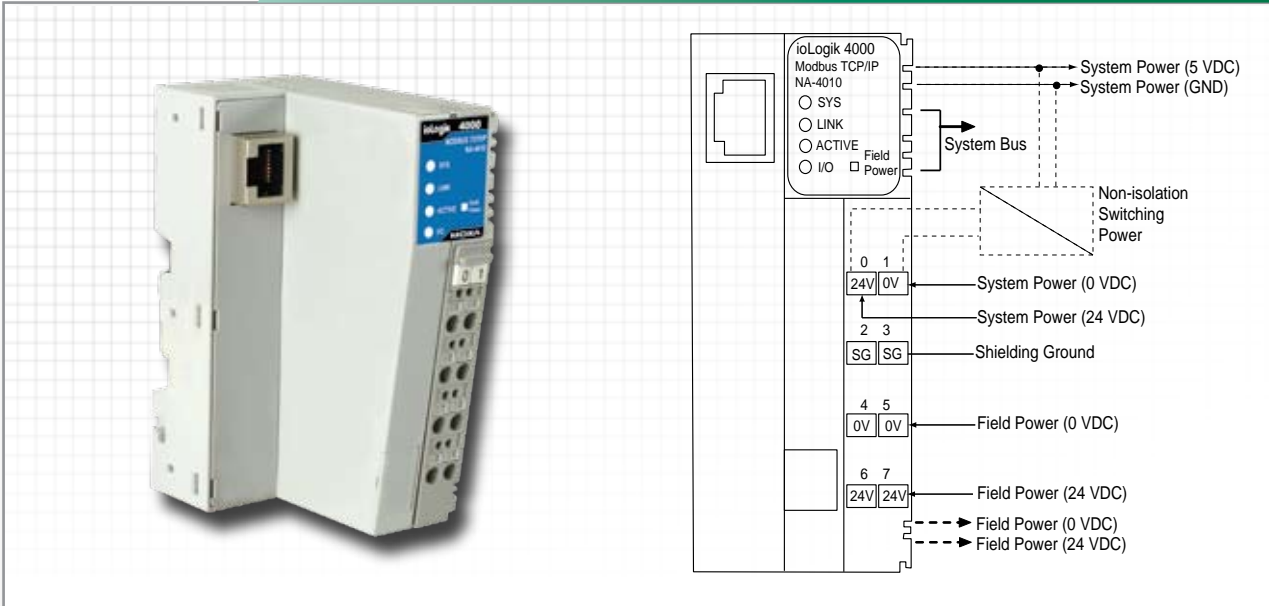

Specifications

Network

Ethernet: 10/100 Mbps, RJ45

Software Features

Protocols: Modbus/TCP, HTTP, Bootp

IP settings: ARP, Bootp, static IP

Utility: ioAdmin

Programming library: MXIO DLL library for Windows supporting Visual Basic, Visual C++, Borland C++ Builder

Max. I/O modules: Up to 32 I/O expansion modules

System Power

Power input: 11 to 28.8 VDC, 24 VDC typical

Power consumption: 60 mA typical @ 24 VDC

Current for I/O modules: Max. 1.5A @ 5 VDC

Field power

Rated voltage: 11 to 28.8 VDC, 24 VDC typical

Current in field power contact: Max. 10A

Protection

System power to I/O driver: 2 KV rms optical isolation

Environmental

Operating Temperature: -20 to 60°C, 5 to 90%RH

Storage Temperature: -45 to 85°C

Vibration: IEC-68-2-6, 2G in operation

Agency Approvals

EMC: CE EN-55082, EN-55081

Safety: UL 508

Weight

Net weight: 150 g

Pin Assignment

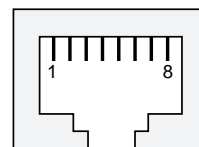

PIN	Signals
1	Tx+
2	Tx-
3	Rx+
6	Rx-

Network Adapter Modules

NA-4020 RS-485 Network Adapter
NA-4021 RS-232 Network Adapter

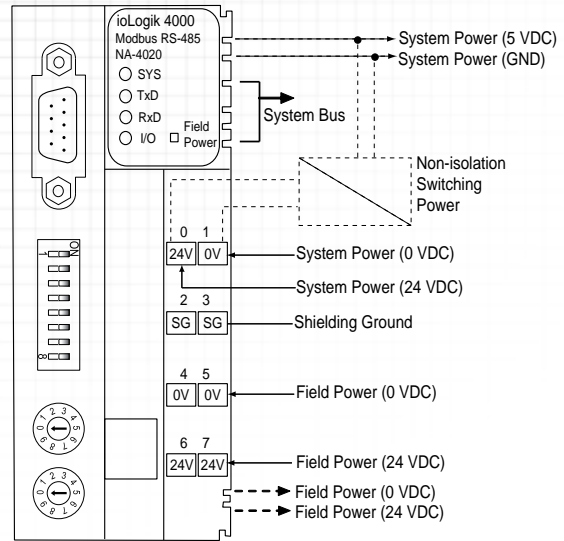

Specifications

Serial Communication

Baudrate: 1200 to 115200 bps
Data bits: 7, 8
Parity bit: None, Even, Odd
Stop bit: 1, 2
Signal: NA-4020: Data+, Data-, Gnd, DIR
 NA-4021: TxD, RxD, Gnd

Software Features

Protocols: Modbus/RTU, Modbus/ASCII
Modbus Address: 00 to 99 by rotary switches
Utility: ioAdmin
Programming library: MXIO DLL library for Windows supporting Visual Basic, Visual C++, Borland C++ Builder
Max. I/O modules: Up to 32 I/O expansion modules

System Power

Power input: 11 to 28.8 VDC, 24 VDC typical
Power consumption: 70 mA typical @ 24 VDC
Current for I/O modules: Max. 1.5A @ 5 VDC

Field power

Rated voltage: 11 to 28.8 VDC, 24 VDC typical
Current in field power contact: Max. 10A

Protection

System power to I/O driver: 2 KV rms optical isolation

Environmental

Operating Temperature: -20 to 60°C, 5 to 90%RH
Storage Temperature: -45 to 85°C
Vibration: IEC-68-2-6, 2G in operation

Agency Approvals

EMC: CE EN-55082, EN-55081
Safety: UL 508

Weight

Net weight: 150 g

Pin Assignment

Female DB9

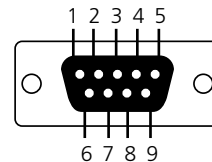

NA-4020		NA-4021	
PIN	Signals	PIN	Signals
1	---	1	---
2	---	2	TxD
3	Data+	3	RxD
4	Direction (Output)	4	---
5	GND	5	GND
6	---	6	---
7	---	7	---
8	Data-	8	---

Digital Input Modules

4/8-channel 24/48 VDC Digital Input Modules

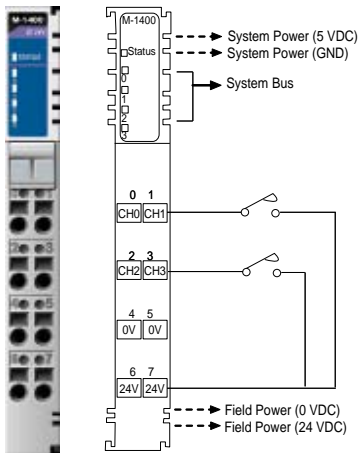

M-1400 4 Digital inputs, sink, 24 VDC

Input Specifications

- Inputs per module:** 4 points, sink type
- On-state voltage:** 24 VDC nominal, Min. 11 VDC to Max. 28.8 VDC
- Min. Off-state voltage:** Max. 5 VDC
- On-state current:** Max. 6 mA / point @ 28.8 VDC
- Input impedance:** Typ. 5.1 Kohm
- Filtering time:** Typ. 1.5 ms
- Common type:** 4 points/2 COM

General Specifications

- Power consumption:** Max. 35 mA @ 5 VDC
- Isolation:** I/O to logic: 2 KV rms optical isolation
- Field power:** Supply voltage: 24 VDC nominal
- Wiring:** I/O cable max. AWG14

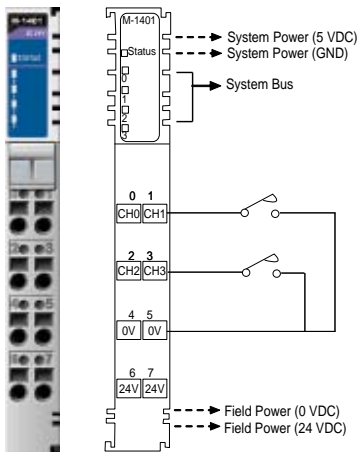

M-1401 4 Digital inputs, source, 24 VDC

Input Specifications

- Inputs per module:** 4 points, source type
- On-state voltage:** 24 VDC nominal, Min. 11 VDC to Max. 28.8 VDC
- Min. Off-state voltage:** Max. 5 VDC
- On-state current:** Max. 6 mA / point @ 28.8 VDC
- Input impedance:** Typ. 5.1 Kohm
- Filtering time:** Typ. 1.5 ms
- Common type:** 4 points/2 COM

General Specifications

- Power consumption:** Max. 35 mA @ 5 VDC
- Isolation:** I/O to logic: 2 KV rms optical isolation
- Field power:** Supply voltage: 24 VDC nominal
- Wiring:** I/O cable max. AWG14

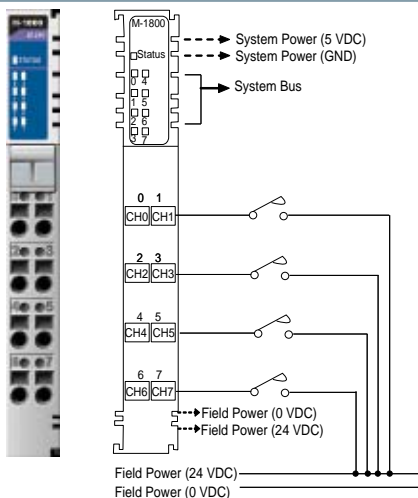

M-1800 8 Digital inputs, sink, 24 VDC

Input Specifications

- Inputs per module:** 8 points, sink type
- On-state voltage:** 24 VDC nominal, Min. 11 VDC to Max. 28.8 VDC
- Min. Off-state voltage:** Max. 5 VDC
- On-state current:** Max. 6 mA / point @ 28.8 VDC
- Input impedance:** Typ. 5.1 Kohm
- Filtering time:** Typ. 1.5 ms
- Common type:** External common

General Specifications

- Power consumption:** Max. 35 mA @ 5 VDC
- Isolation:** I/O to logic: 2 KV rms optical isolation
- Field power:** Supply voltage: 24 VDC nominal
- Wiring:** I/O cable max. AWG14



Digital Input Modules

4/8-channel 24/48 VDC Digital Input Modules

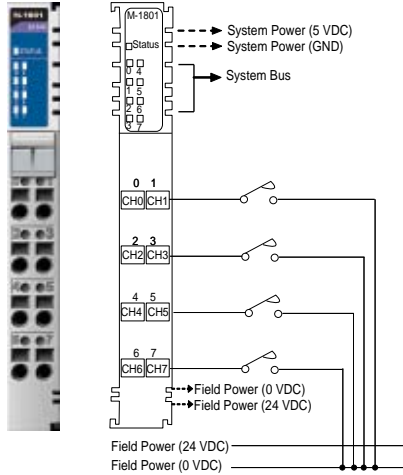

M-1801 8 Digital inputs, source, 24 VDC

Input Specifications

- Inputs per module:** 8 points, source type
- On-state voltage:** 24 VDC nominal, Min. 11 VDC to Max. 28.8 VDC
- Min. Off-state voltage:** Max. 5 VDC
- On-state current:** Max. 6 mA / point @ 28.8 VDC
- Input impedance:** Typ. 5.1 Kohm
- Filtering time:** Typ 1.5 ms
- Common type:** External common

General Specifications

- Power consumption:** Max. 35 mA @ 5 VDC
- Isolation:** I/O to logic: 2 KV rms optical isolation
- Field power:** Supply voltage: 24 VDC nominal
- Wiring:** I/O cable max. AWG14

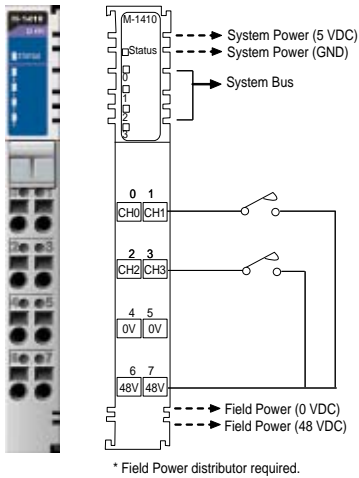

* Field Power distributor required.

M-1410 4 Digital inputs, sink, 48 VDC

Input Specifications

- Inputs per module:** 4 points, sink type
- On-state voltage:** 48 VDC nominal, Min. 34 VDC to Max. 60 VDC
- Min. Off-state voltage:** Max. 10 VDC
- On-state current:** Max. 4 mA / point @ 48 VDC
- Input impedance:** Typ. 12 Kohm
- Common type:** 4 points/2 COM

General Specifications

- Power consumption:** Max. 35 mA @ 5 VDC
- Isolation:** I/O to logic: 2 KV rms optical isolation
- Field power:** Supply voltage: 48 VDC nominal
- Wiring:** I/O cable max. AWG14

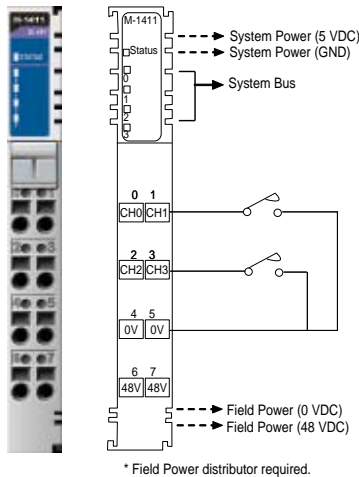

* Field Power distributor required.

M-1411 4 Digital inputs, source, 48 VDC

Input Specifications

- Inputs per module:** 4 points, source type
- On-state voltage:** 48 VDC nominal, Min. 34 VDC to Max. 60 VDC
- Min. Off-state voltage:** Max. 10 VDC
- On-state current:** Max. 4 mA / point @ 48 VDC
- Input impedance:** Typ. 12 Kohm
- Common type:** 4 points/2 COM

General Specifications

- Power consumption:** Max. 35 mA @ 5 VDC
- Isolation:** I/O to logic: 2 KV rms optical isolation
- Field power:** Supply voltage: 48 VDC nominal
- Wiring:** I/O cable max. AWG14



Digital Input Modules

16-channel 24 VDC Digital Input Modules

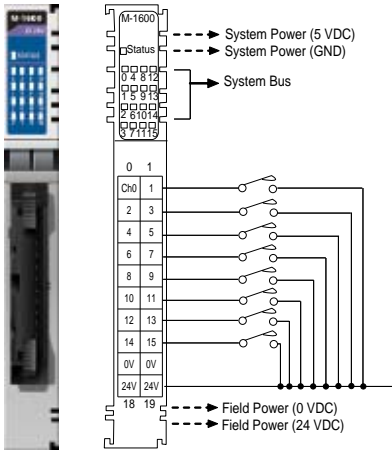

M-1600 16 Digital inputs, sink, 24 VDC

Input Specifications

- Inputs per module:** 16 points, sink type
- On-state voltage:** 24 VDC nominal, Min. 11 VDC to Max. 28.8 VDC
- Min. Off-state voltage:** Max. 5 VDC
- On-state current:** Max. 6 mA / point @ 28.8 VDC
- Input impedance:** Typ. 5.1 Kohm
- Filtering time:** Typ. 1.5 ms
- Common type:** 16 points/2 COM

General Specifications

- Power consumption:** Max. 40 mA @ 5 VDC
- Isolation:** I/O to logic: 2 KV rms optical isolation
- Field power:** Supply voltage: 24 VDC nominal
- Wiring:** I/O cable max. AWG14

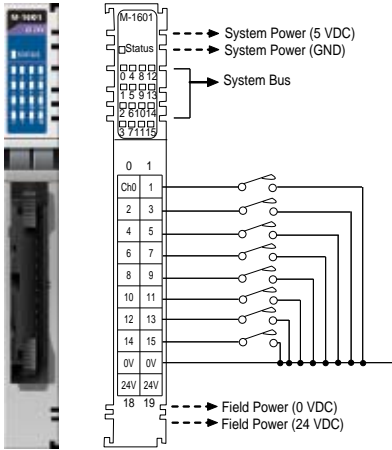

M-1601 16 Digital inputs, source, 24 VDC

Input Specifications

- Inputs per module:** 16 points, source type
- On-state voltage:** 24 VDC nominal, Min. 11 VDC to Max. 28.8 VDC
- Min. Off-state voltage:** Max. 5 VDC
- On-state current:** Max. 6 mA / point @ 28.8 VDC
- Input impedance:** Typ. 5.1 Kohm
- Filtering time:** Typ. 1.5 ms
- Common type:** 16 points/2 COM

General Specifications

- Power consumption:** Max. 40 mA @ 5 VDC
- Isolation:** I/O to logic: 2 KV rms optical isolation
- Field power:** Supply voltage: 24 VDC nominal
- Wiring:** I/O cable max. AWG14



Digital Input Modules

4-channel 110V/240 VAC Digital Input Modules

3

Expandable Remote I/O

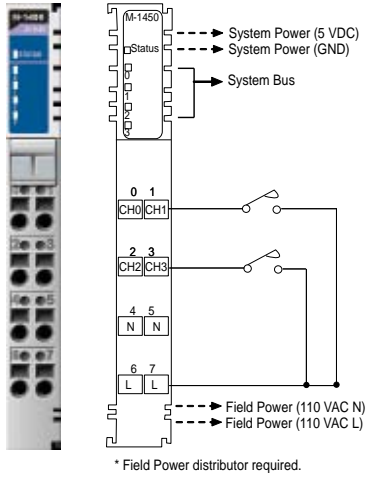

* Field Power distributor required.

M-1450 4 Digital inputs, 110 VAC

Input Specifications

- Inputs per module:** 4 points
- On-state voltage:** 120 VAC nominal, Min. 85 VAC to Max. 132 VAC
- Min. Off-state voltage:** Max. 45 VAC
- On-state current:** Max. 8 mA / point @ 132 VAC
- Input impedance:** Typ. 11 Kohm
- Common type:** 4 points/2 COM (single common)

General Specifications

- Power consumption:** Max. 35 mA @ 5 VDC
- Isolation:** I/O to logic: 2 KV rms optical isolation
- Field power:** Supply voltage: 110 VAC nominal
- Wiring:** I/O cable max. AWG14

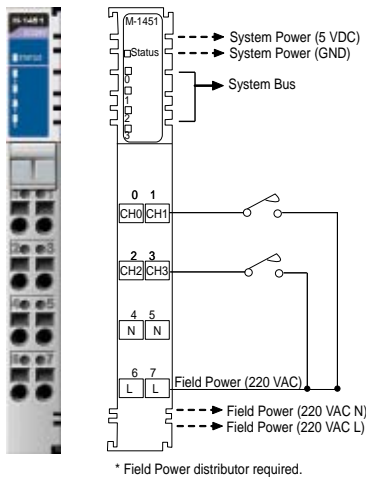

* Field Power distributor required.

M-1451 4 Digital inputs, 220 VAC

Input Specifications

- Inputs per module:** 4 points
- On-state voltage:** 240 VAC nominal, Min. 170 VAC to Max. 264 VAC
- Min. Off-state voltage:** Max. 45 VAC
- On-state current:** Max. 12 mA / point @ 264 VAC
- Input impedance:** Typ. 22 Kohm
- Common type:** 4 points/2 COM (single common)

General Specifications

- Power consumption:** Max. 35 mA @ 5 VDC
- Isolation:** I/O to logic: 2 KV rms optical isolation
- Field power:** Supply voltage: 220 VAC nominal
- Wiring:** I/O cable max. AWG14



Digital Output Modules

4/8-channel 24 VDC Digital Output Modules

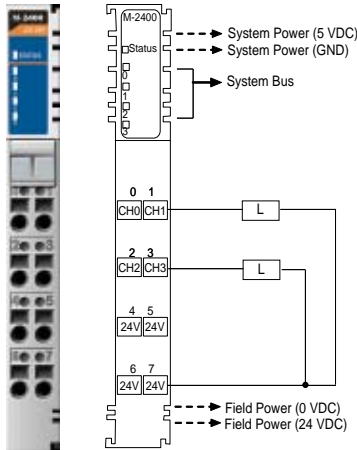

M-2400 4 Digital outputs, sink, 24 VDC, 0.5A

Output Specifications

- Outputs per module:** 4 points, sink type
- On-state voltage:** 24 VDC nominal, Min. 11 VDC to Max. 28.8 VDC
- Operating frequency:** 50 Khz on DC power
- On-state voltage drop:** Max. 0.3 VDC @ 25°C
- On-state current:** Min. 1 mA per channel
- Off leakage current:** Max. 50 μ A
- Output current rating:** Max. 0.5A per channel
Max. 2A per common
- Protection:** Over temperature shutdown: Typ. 175°C
Over current limit: 6.5A per 1/2/4 channels
Short circuit protection: 6.5A per 4 channels
ESD protection for output pin: 16.5 KV
- Surge current:** 1A for 10 ms, repeatable every 3 seconds
- Common type:** 4 points /4 COM (single common)

General Specifications

- Power consumption:** Max. 45 mA @ 5 VDC
- Isolation:** I/O to logic: 2 KV rms optical isolation
- Field power:** Supply voltage: 24 VDC nominal
- Wiring:** I/O cable max. AWG14

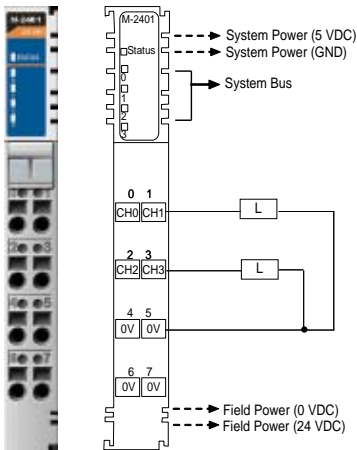

M-2401 4 Digital outputs, source, 24 VDC, 0.5A

Output Specifications

- Outputs per module:** 4 points, source type
- On-state voltage:** 24 VDC nominal, Min. 11 VDC to Max. 28.8 VDC
- Operating frequency:** 50 Khz on DC power
- On-state voltage drop:** Max. 0.3 VDC @ 25°C
- On-state current:** Min. 1 mA per channel
- Off leakage current:** Max. 50 μ A
- Output current rating:** Max. 0.5A per channel
Max. 2A per common
- Protection:** Over temperature shutdown: Typ. 175°C
Over current limit: 6.5A per 1/2/4 channels
Short circuit protection: 6.5A per 4 channels
ESD protection for output pin: 16.5 KV
- Surge current:** 1A for 10 ms, repeatable every 3 seconds
- Common type:** 4 points/4 COM (single common)

General Specifications

- Power consumption:** Max. 45 mA @ 5 VDC
- Isolation:** I/O to logic: 2 KV rms optical isolation
- Field power:** Supply voltage: 24 VDC nominal
- Wiring:** I/O cable max. AWG14

Digital Output Modules

4/8-channel 24 VDC Digital Output Modules

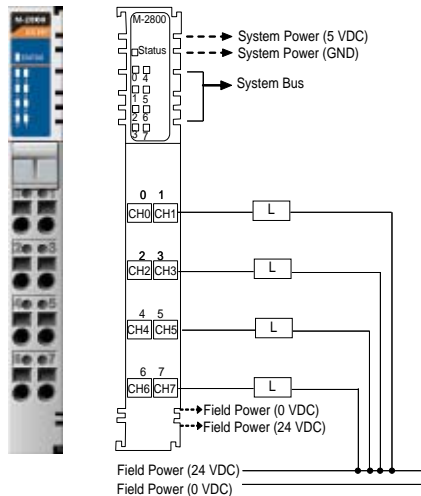

M-2800 8 Digital outputs, sink, 24 VDC, 0.5A

Output Specifications

- Outputs per module:** 8 points, sink type
- On-state voltage:** 24 VDC nominal, Min. 11 VDC to Max. 28.8 VDC
- Operating frequency:** 50 Khz on DC power
- On-state voltage drop:** Max. 0.3 VDC @ 25°C
- On-state current:** Min. 1 mA per channel
- Off leakage current:** Max. 50 μ A
- Output current rating:** Max. 0.5A per channel
Max. 4A per common
- Protection:** Over temperature shutdown: Typ. 175°C
Over current limit: 1.7A
ESD protection for output pin: 16.5 KV
- Surge current:** 1A for 10 ms, repeatable every 3 seconds
- Common type:** 8 points/External common (single common)

General Specifications

- Power consumption:** Max. 60 mA @ 5 VDC
- Isolation:** I/O to logic: 2 KV rms optical isolation
- Field power:** Supply voltage: 24 VDC nominal
- Wiring:** I/O cable max. AWG14

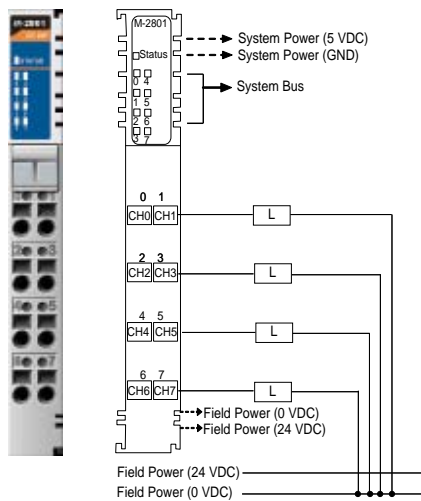

M-2801 8 Digital outputs, source, 24 VDC, 0.5A

Output Specifications

- Outputs per module:** 8 points, source type
- On-state voltage:** 24 VDC nominal, Min. 11 VDC to Max. 28.8 VDC
- Operating frequency:** 50 Khz on DC power
- On-state voltage drop:** Max. 0.3 VDC @ 25°C
- On-state current:** Min. 1 mA per channel
- Off leakage current:** Max. 50 μ A
- Output current rating:** Max. 0.5A per channel
Max. 4A per common
- Protection:** Over temperature shutdown: Typ. 175°C
Over current limit: 1.7A
ESD protection for output pin: 16.5 KV
- Surge current:** 1A for 10 ms, repeatable every 3 seconds
- Common type:** 8 points/External common (single common)

General Specifications

- Power consumption:** Max. 60 mA @ 5 VDC
- Isolation:** I/O to logic: 2 KV rms optical isolation
- Field power:** Supply voltage: 24 VDC nominal
- Wiring:** I/O cable max. AWG14



Digital Output Modules

4-channel Digital Output Modules with Self-Diagnostics

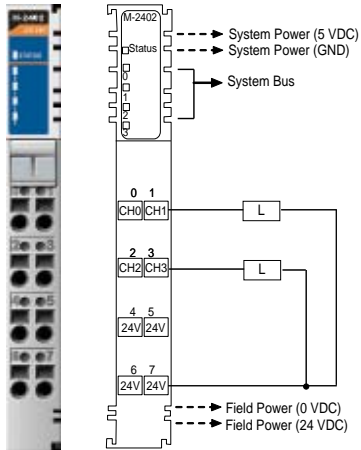

M-2402 4 Digital outputs, self-diagnostics, sink, 24 VDC, 0.5A

Output Specifications

- Outputs per module:** 4 points, sink type
- On-state voltage:** 24 VDC nominal, Min. 11 VDC to Max. 28.8 VDC
- Operating frequency:** 50 KHz on DC power
- On-state voltage drop:** Max. 0.3 VDC @25°C
- On-state current:** Min. 1 mA per channel
- Off leakage current:** Max. 50 μ A
- Output current rating:** Max. 0.5A per channel
Max. 2A per common

- Protection:** Over temperature shutdown: Typ. 175°C
Over current limit: 6.5A per 1/2/4 channels
Short circuit protection: 6.5A per 4 channels
ESD protection for output pin: 16.5 KV

- Surge current:** 1A for 10 ms, repeatable every 3 seconds
- Common type:** 4 points/4 COM (single common)
- Self diagnostics:** Yes

General Specifications

- Power consumption:** Max. 45 mA @ 5 VDC
- Isolation:** I/O to logic: 2 KV rms optical isolation
- Field power:** Supply voltage: 24 VDC nominal
- Wiring:** I/O cable max. AWG14

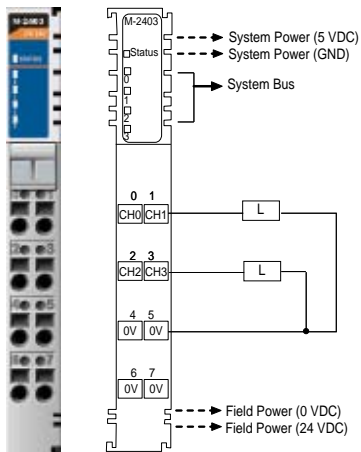

M-2403 4 Digital outputs, self-diagnostics, source, 24 VDC, 0.5A

Output Specifications

- Outputs per module:** 4 points, source type
- On-state voltage:** 24 VDC nominal, Min. 11 VDC to Max. 28.8 VDC
- Operating frequency:** 50 KHz on DC power
- On-state voltage drop:** Max. 0.3 VDC @ 25°C
- On-state current:** Min. 1 mA per channel
- Off leakage current:** Max. 50 μ A
- Output current rating:** Max. 0.5A per channel
Max. 2A per common

- Protection:** Over temperature shutdown: Typ. 175°C
Over current limit: 6.5A per 1/2/4 channels
Short circuit protection: 6.5A per 4 channels
ESD protection for output pin: 16.5 KV

- Surge current:** 1A for 10 ms, repeatable every 3 seconds
- Common type:** 4 points /4 COM (single common)
- Self diagnostics:** Yes

General Specifications

- Power consumption:** Max. 45 mA @ 5 VDC
- Isolation:** I/O to logic: 2 KV rms optical isolation
- Field power:** Supply voltage: 24 VDC nominal
- Wiring:** I/O cable max. AWG14



Digital Output Modules

4-channel Digital Output Modules with Self-Diagnostics

3

Expandable Remote I/O

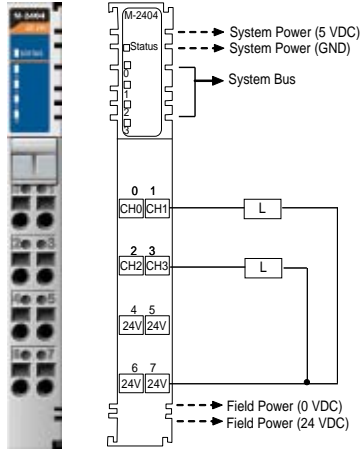

M-2404 4 Digital output, self-diagnostics, sink, 24 VDC, 2A

Output Specifications

- Outputs per module:** 4 points, sink type
- On-state voltage:** 24 VDC nominal, Min. 11 VDC to Max. 28.8 VDC
- Operating frequency:** 50 Khz on DC power
- On-state voltage drop:** Max. 0.3 VDC @ 25°C
- On-state current:** Min. 1 mA per channel
- Off leakage current:** Max. 50 μ A
- Output current rating:** Max. 2A per channel
Max. 8A per common
- Protection:** Over temperature shutdown: Typ. 175°C
Over current limit: 6.5A
Short circuit protection: 6.5A per 4 channels
ESD protection for output pin: 16.5 KV
- Surge current:** 1A for 10 ms, repeatable every 3 seconds
- Common type:** 4 points/4 COM (single common)
- Self diagnostics:** Yes

General Specifications

- Power consumption:** Max. 45 mA @ 5 VDC
- Isolation:** I/O to logic: 2 KV rms optical isolation
- Field power:** Supply voltage: 24 VDC nominal
- Wiring:** I/O cable max. AWG14

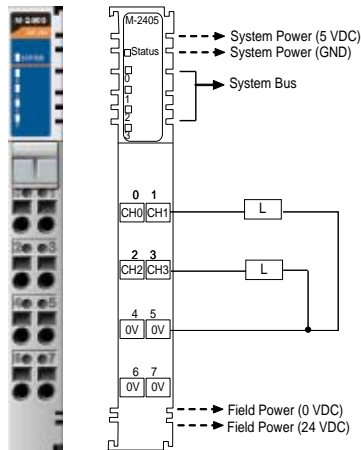

M-2405 4 Digital outputs, self-diagnostics, source, 24 VDC, 2A

Output Specifications

- Outputs per module:** 4 points, source type
- On-state voltage:** 24 VDC nominal, Min. 11 VDC to Max. 28.8 VDC
- Operating frequency:** 50 Khz on DC power
- On-state voltage drop:** Max. 0.3 VDC @ 25°C
- On-state current:** Min. 1 mA per channel
- Off leakage current:** Max. 50 μ A
- Output current rating:** Max. 2A per channel
Max. 8A per common
- Protection:** Over temperature shutdown: Typ. 175°C
Over current limit: 6.5A
Short circuit protection: 6.5A per 4 channels
ESD protection for output pin: 16.5 KV
- Surge current:** 1A for 10 ms, repeatable every 3 seconds
- Common type:** 4 points/4 COM (single common)
- Self diagnostics:** Yes

General Specifications

- Power consumption:** Max. 45 mA @ 5 VDC
- Isolation:** I/O to logic: 2 KV rms optical isolation
- Field power:** Supply voltage: 24 VDC nominal
- Wiring:** I/O cable max. AWG14

Digital Output Modules

16-channel Digital Output Modules

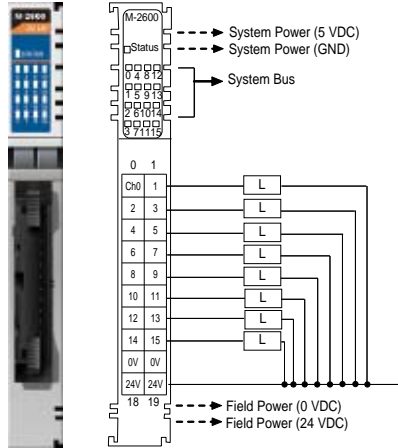

M-2600 16 Digital outputs, sink, 24 VDC, 0.3A

Output Specifications

- Outputs per module:** 16 points, sink type
- On-state voltage:** 24 VDC nominal, Min. 11 VDC to Max. 28.8 VDC
- Operating frequency:** 50 KHz on DC power
- On-state voltage drop:** Max. 0.3 VDC @ 25°C
- On-state current:** Min. 1 mA per channel
- Off leakage current:** Max. 50 μA
- Output current rating:** Max. 0.3A per channel
Max. 4A per common
- Protection:** Over temperature shutdown: Typ. 175°C
Over current protection: one time electrical fuse (125 VDC/6.3A)

Common type: 16 points / 2 COM (single common)

General Specifications

- Power consumption:** Max. 80 mA @ 5 VDC
- Isolation:** I/O to logic: optical isolation, 500 VAC/min, terminal to FG
- Field power:** Supply voltage: 24 VDC nominal
- Wiring:** Pin header, external relay board required

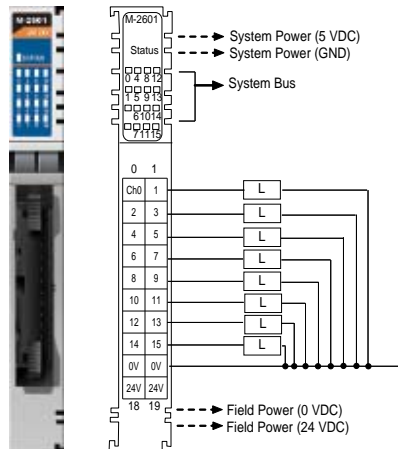

M-2601 16 Digital outputs, source, 24 VDC, 0.3A

Output Specifications

- Outputs per module:** 16 points, source type
- On-state voltage:** 24 VDC nominal, Min. 11 VDC to Max. 28.8 VDC
- Operating frequency:** 50 KHz on DC power
- On-state voltage drop:** Max. 0.3 VDC @ 25°C
- On-state current:** Min. 1 mA per channel
- Off leakage current:** Max. 50 μA
- Output current rating:** Max. 0.3A per channel
Max. 4A per common
- Protection:** Over temperature shutdown: Typ. 175°C
Over current protection: one time electrical fuse (125 VDC/6.3A)

Common type: 16 points / 2 COM (single common)

General Specifications

- Power consumption:** Max. 80 mA @ 5 VDC
- Isolation:** I/O to logic: optical isolation, 500 VAC/min, terminal to FG
- Field power:** Supply voltage: 24 VDC nominal
- Wiring:** Pin header, external relay board required

Digital Output Modules

2-channel Relay Output Module

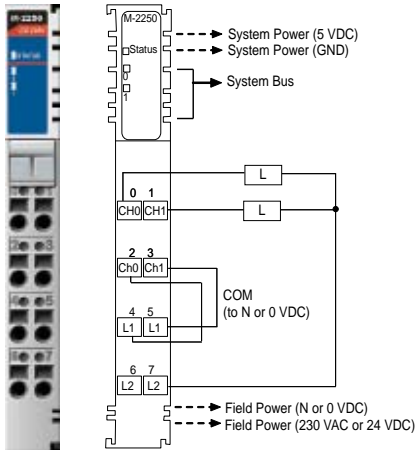

* Field Power distributor required when the field power is not 24 VDC.

M-2250 2 Digital outputs, relay, 24 VDC/ 230 VAC, 2A

Output Specifications

Outputs per module: 2 points, relay

Relay type: Form A, Normally Open (N.O.)

Single pole, single throw (SPST)

Output voltage range: Load dependent
 5 to 28.8 VDC @ 2A resistive
 48 VDC @ 0.8A resistive
 110 VAC @ 0.3A resistive
 250 VAC @ 2A resistive

Output current rating: at rated power
 2A @ 5 to 28.8 VDC
 0.8A @ 48 VDC
 0.5A @ 110 VAC
 2A @ 250 VAC

Min. Load: 100 μ A, 100 m VDC per point

Max. on-state voltage drop: 0.5V @ 2A, resistive load, 24 VDC

Off-state leakage current: Max. 1.5 mA

Common type: 1 point/1 COM

General Specifications

Power consumption: Max. 65 mA @ 5 VDC

Wiring: I/O cable Max. AWG14

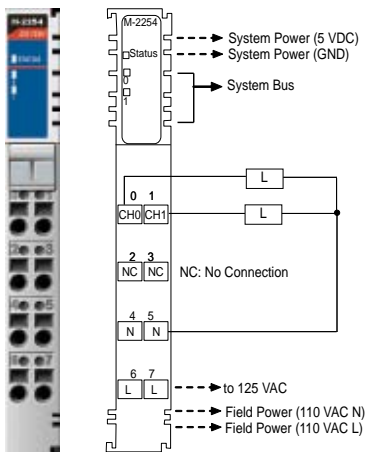

* Field Power distributor required when the field power is not 24 VDC.

M-2254 2 Digital outputs, Triac, 12 to 125 VAC, 0.5A

Output Specifications

Outputs per module: 2 points

Switch type: Zero crossing

Rated load voltage: 15 to 132 VAC

Output current rating: 0.05 to 0.5A

Frequency range: 47 to 63 Hz

Surge current: 40A (16 ms) /4A (30S)

On-state voltage drop: 1.3 Vrms (Max. load)

Off-state leakage current: Max. 1.5 mA

Common type: 2 points / 2 COM

General Specifications

Power consumption: Max. 35 mA @ 5 VDC

Wiring: I/O cable Max. AWG14



Analog Input Modules

General Resolution

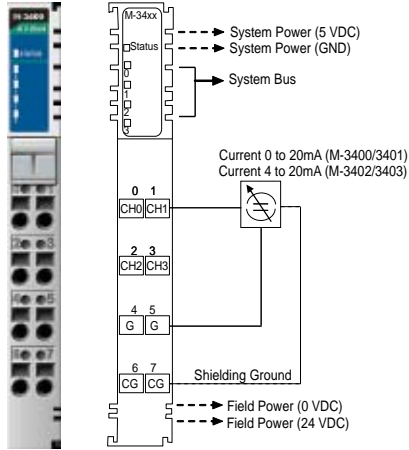

M-3400 4 Analog inputs, 0 to 20 mA, 12-bit
M-3402 4 Analog inputs, 4 to 20 mA, 12-bit

Input Specifications

Resolution in ranges: 12 bits, 4.88 μ A/bit (M-3400)
 12 bits, 3.91 μ A/bit (M-3402)

Input current range: 0 to 20 mA (M-3400)
 4 to 20 mA (M-3402)

Data format: 16-bit integer (2's complement)

Accuracy: +/- 0.1%, FSR @ 25°C
 +/- 0.3%, FSR @ 0°C, 60°C

Input impedance: 120 ohm

Conversion time: 4 msec. / all channels

General Specifications

Power consumption: Max. 150 mA @ 5 VDC

Isolation: I/O to logic: 1K VDC galvanic isolation

Wiring: I/O cable max. AWG14

Conversion Table (M-3400)

Current	0 mA	5 mA	10 mA	20 mA
Data (Hex)	H0000	H03FF	H07FF	H0FFF

Conversion Table (M-3402)

Current	4 mA	5 mA	10 mA	20 mA
Data (Hex)	H0000	H00FF	H05FF	H0FFF

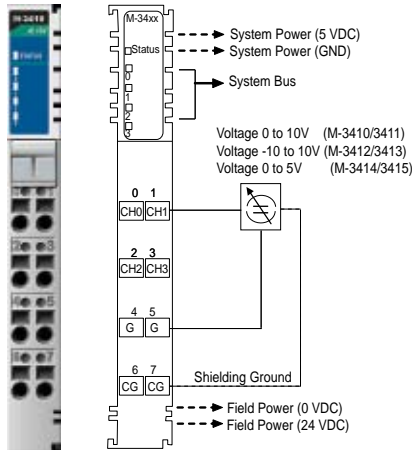

M-3410 4 Analog inputs, 0 to 10V, 12-bit
M-3412 4 Analog inputs, -10 to 10V, 12-bit
M-3414 4 Analog inputs, 0 to 5V, 12-bit

Input Specifications

Resolution in ranges: 12 bits, 2.44 mV/bit (M-3410)
 12 bits, 4.88 mV/bit (M-3412)
 12 bits, 1.22 mV/bit (M-3414)

Input current range: 0 to 10 VDC (M-3410)
 -10 to 10 VDC (M-3412)
 0 to 5 VDC (M-3414)

Data format: 16-bit integer (2's complement)

Accuracy: +/- 0.1%, FSR @ 25°C
 +/- 0.3%, FSR @ 0°C, 60°C

Input impedance: 500 Kohm

Conversion time: 4 msec. / all channels

General Specifications

Power consumption: Max. 150 mA @ 5 VDC

Isolation: I/O to logic: 1K VDC galvanic isolation

Wiring: I/O cable max. AWG14

Conversion Table (M-3410)

Voltage	0V	2V	5V	10V
Data (Hex)	H0000	H0333	H07FF	H0FFF

Conversion Table (M-3412)

Voltage	-10V	-5V	0V	5V	10V
Data (Hex)	HF800	HFC00	H0000	H3FFF	H07FF

Conversion Table (M-3414)

Voltage	0V	2V	4V	5V
Data (Hex)	H0000	H0666	HOCCC	H0FFF

Analog Input Modules

High Resolution

3

Expandable Remote I/O

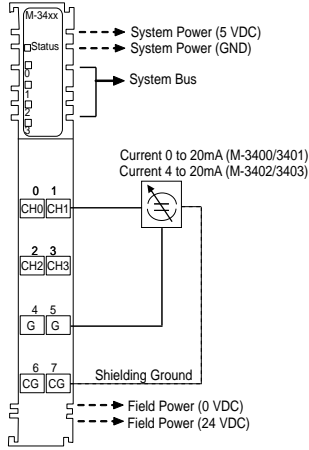

M-3401 4 Analog inputs, 0 to 20 mA, 14-bit
M-3403 4 Analog inputs, 4 to 20 mA, 14-bit

Input Specifications

Resolution in ranges: 14 bits, 1.22 μ A/bit (M-3401)
 14 bits, 0.98 μ A/bit (M-3403)

Input current range: 0 to 20 mA (M-3401)
 4-20 mA (M-3403)

Data format: 16-bit integer (2's complement)

Accuracy: +/- 0.1%, FSR @ 25°C
 +/- 0.3%, FSR @ 0°C, 60°C

Input impedance: 120 ohm

Conversion time: 4 msec. / all channels

General Specifications

Power consumption: Max. 150 mA @ 5 VDC

Isolation: I/O to logic: 1K VDC galvanic isolation

Wiring: I/O cable max. AWG14

Conversion Table (M-3401)

Current	0 mA	5 mA	10 mA	20 mA
Data (Hex)	H0000	H0FFF	H1FFF	H3FFF

Conversion Table (M-3403)

Current	4 mA	5 mA	10 mA	20 mA
Data (Hex)	H0000	H03FF	H17FF	H3FFF

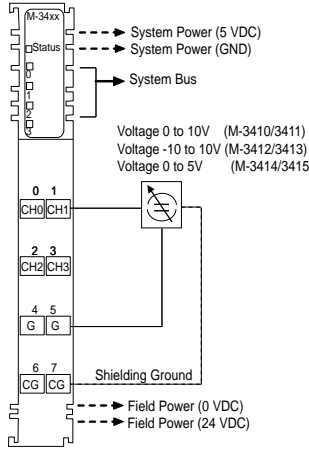

M-3411 4 Analog inputs, 0 to 10V, 14-bit
M-3413 4 Analog inputs, -10 to 10V, 14-bit
M-3415 4 Analog inputs, 0 to 5V, 14-bit

Input Specifications

Resolution in ranges: 14 bits, 0.61 mV/bit (M-3411)
 14 bits, 1.22 mV/bit (M-3413)
 14 bits, 0.31 mV/bit (M-3415)

Input current range: 0 to 10 VDC (M-3411)
 -10 to 10 VDC (M-3413)
 0 to 5 VDC (M-3415)

Data format: 16-bit integer (2's complement)

Accuracy: +/- 0.1%, FSR @ 25°C
 +/- 0.3%, FSR @ 0°C, 60°C

Input impedance: 500K ohm

Conversion time: 4 msec. / all channels

General Specifications

Power consumption: Max. 150 mA @ 5 VDC

Isolation: I/O to logic: 1K VDC galvanic isolation

Wiring: I/O cable max. AWG14

Conversion Table (M-3411)

Voltage	0V	2V	5V	10V
Data (Hex)	H0000	H0CCC	H1FFF	H3FFF

Conversion Table (M-3413)

Voltage	-10V	-5V	0V	5V	10V
Data (Hex)	HE000	HF000	H0000	H0FFF	H1FFF

Conversion Table (M-3415)

Voltage	0V	2V	4V	5V
Data (Hex)	H0000	H1999	H3332	H3FFF



Analog Input Modules

Temperature sensing

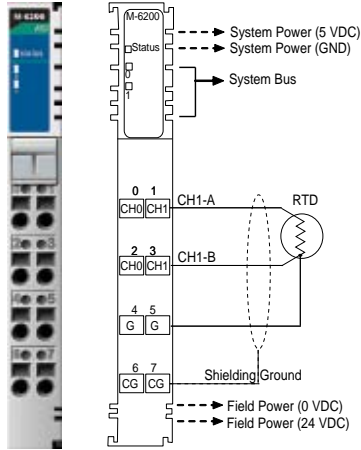

M-6200 2 Analog inputs, RTD: PT100, JPT100

Input Specifications

Sensor types: PT50, PT100, PT200, PT500, PT1000, JPT100, JPT200, JPT500, JPT1000, NI100, NI200, NI500, NI1000, NI120, CU10,
Resistance 100 mohm/bit,
Resistance 10 mohm/bit,
Resistance 20 mohm/bit

Data format: 16-bit integer (2's complement)

Resolution: 0.1°C / 10 mohm

Accuracy: +/- 0.1%, FSR @ 25°C
+/- 0.3%, FSR @ 0°C, 60°C

Input impedance: 500 Kohm

Conversion time: 200 msec. / all channels

Diagnostics: Range over (if range over, data=Dx8000)

General Specifications

Power consumption: Max. 80 mA @ 5VDC

Isolation: I/O to logic: 1K VDC galvanic isolation

Wiring: I/O cable max. AWG14

Conversion Table

Sensor PT100

Temp.	-200 °C	-100 °C	0 °C	200°C	400°C	640°C
Data (Hex)	HF830	HFC18	H0000	H07D0	H0FA0	H1900

Other Sensor Type Data

Sensor Type	Degree	Count	Resolution
Resistance 100 mOhm	1 to 2000 Ohm	10 to 20000	100 mOhm / 1 count
Resistance 10 mOhm	1 to 327 Ohm	10 to 3270	10 mOhm / 1 count
Resistance 20 mOhm	1 to 620 Ohm	10 to 6200	20 mOhm / 1 count
PT50, 0.00385	200 to 850°C	-2000 to 8500	0.1°C or 0.1°F / 1 count
PT100, 0.00385	-200 to 850°C	-2000 to 8500	0.1°C or 0.1°F / 1 count
PT200, 0.00386	-200 to 850°C	-2000 to 8500	0.1°C or 0.1°F / 1 count
PT500, 0.00385	-200 to 850°C	-2000 to 8500	0.1°C or 0.1°F / 1 count
PT1000, 0.00385	-200 to 350°C	-2000 to 3500	0.1°C or 0.1°F / 1 count
JPT100, 0.003916	-200 to 640°C	-2000 to 6400	0.1°C or 0.1°F / 1 count
JPT200, 0.003916	-200 to 640°C	-2000 to 6400	0.1°C or 0.1°F / 1 count
JPT500, 0.003916	-200 to 640°C	-2000 to 6400	0.1°C or 0.1°F / 1 count
JPT1000, 0.003916	-200 to 350°C	-2000 to 3500	0.1°C or 0.1°F / 1 count
NI100, 0.00618	-60 to 250°C	-600 to 2500	0.1°C or 0.1°F / 1 count
NI120, 0.00672	-80 to 250°C	-800 to 2500	0.1°C or 0.1°F / 1 count
NI200, 0.00618	-60 to 250°C	-600 to 2500	0.1°C or 0.1°F / 1 count
NI500, 0.00618	-60 to 250°C	-600 to 2500	0.1°C or 0.1°F / 1 count
NI1000, 0.00618	-60 to 180°C	-600 to 2500	0.1°C or 0.1°F / 1 count
CU10, 0.00427	-200 to 260°C	-2000 to 2600	0.1°C or 0.1°F / 1 count



Analog Input Modules

Temperature sensing

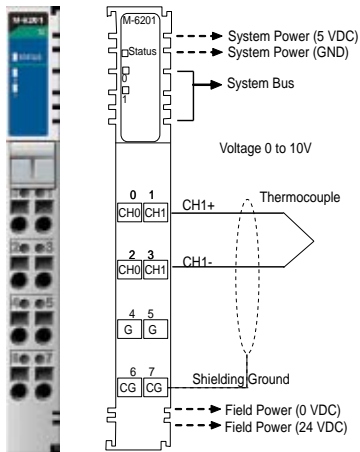

M-6201 2 Analog inputs, Thermocouple

Input Specifications

Sensor types: Type J/K/T/E/R/S/B/N/L/U/C/D
mV input 10 μ V/bit, 2 μ V/bit

Data format: 16-bit integer (2's compliment)

Resolution: 0.1°C / 10 mohm

Accuracy: +/- 0.1%, FSR @ 25°C
+/- 0.3%, FSR @ 0°C, 60°C

Input impedance: 500 Kohm

Conversion time: 200 msec. / all channels

Diagnostics: Range over (if range over, data=Dx8000)

General Specifications

Power consumption: Max. 80 mA @ 5 VDC

Isolation: I/O to logic: 1K VDC galvanic isolation

Wiring: I/O cable max. AWG14

Conversion Table

Type B

Temp.	0 °C	300°C	900 °C	1800°C
Data (Hex)	H0000	H0BB8	H2328	H4650

Other Sensor Type Data

Sensor Type	Degree	Count	Resolution
K	-200 to 12000°C	-6 to 54 mV	0.1°C, °F/bit
J	-40 to 11000°C	-8 to 69 mV	0.1°C, °F/bit
T	-200 to 350°C	-6 to 20 mV	0.1°C, °F/bit
B	600 to 1700°C	0 to 13 mV	0.1°C, °F/bit
R	0 to 1600°C	0 to 21 mV	0.1°C, °F/bit
S	0 to 1600°C	0 to 18 mV	0.1°C, °F/bit
E	-200 to 800°C	-9 to 76 mV	0.1°C, °F/bit
N	-200 to 1250°C	-4 to 47 mV	0.1°C, °F/bit
L	-150 to 850°C	-8 to 53 mV	0.1°C, °F/bit
U	-150 to 550°C	-5 to 34 mV	0.1°C, °F/bit
C	100 to 2200°C	0 to 37 mV	0.1°C, °F/bit
D	100 to 2300°C	0 to 41 mV	0.1°C, °F/bit
Voltage 10 μ V/bit			10 μ V/bit
Voltage 1 μ V/bit			1 μ V/bit
Voltage 2 μ V/bit			2 μ V/bit



Analog Output Modules

General Resolution

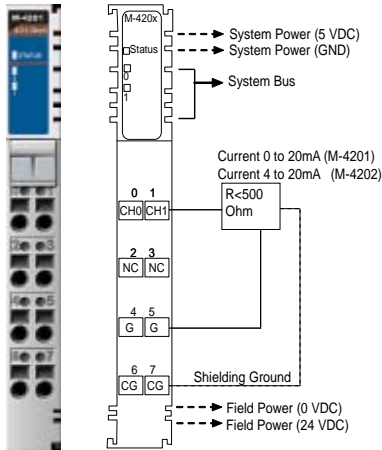

M-4201 2 Analog outputs, 0 to 20 mA, 12-bit
M-4202 2 Analog outputs, 4 to 20 mA, 12-bit

Output Specifications

Resolution in ranges: 12 bits, 4.88 μ A/bit (M-4201)
 12 bits, 3.91 μ A/bit (M-4202)

Output current range: 0 to 20 mA (M-4201)
 4 to 20 mA (M-4202)

Data format: 16-bit integer (2's complement)

Accuracy: +/- 0.1%, FSR @ 25°C
 +/- 0.3%, FSR @ 0°C, 60°C

Output impedance: Max. 500 ohm

Conversion time: 2 msec. / all channels

General Specifications

Power consumption: Max. 65 mA @ 5 VDC

Isolation: I/O to logic: 1K VDC galvanic isolation

Wiring: I/O cable max. AWG14

Conversion Table (M-4201)

Current	0 mA	5 mA	10 mA	20 mA
Data (Hex)	H0000	H03FF	H07FF	H0FFF

Conversion Table (M-4202)

Current	4 mA	5 mA	10 mA	20 mA
Data (Hex)	H0000	H00FF	H05FF	H0FFF

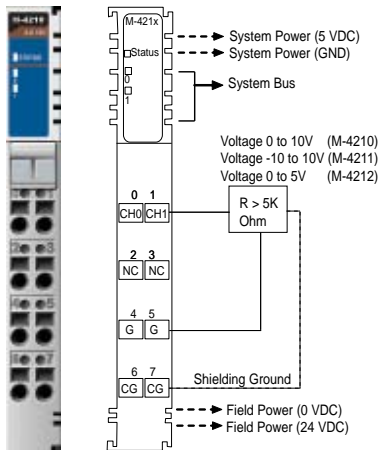

M-4210 2 Analog outputs, 0 to 10V, 12-bit
M-4211 2 Analog outputs, -10 to 10V, 12-bit
M-4212 2 Analog outputs, 0 to 5V, 12-bit

Input Specifications

Resolution in ranges: 12 bits, 2.44 mV/bit (M-4210)
 12 bits, 4.88 mV/bit (M-4211)
 12 bits, 1.22 mV/bit (M-4212)

Output current range: 0 to 10 VDC (M-4210)
 -10 to 10 VDC (M-4211)
 0 to 5 VDC (M-4212)

Data format: 16-bit integer (2's complement)

Accuracy: +/- 0.1%, FSR @ 25°C
 +/- 0.3%, FSR @ 0°C, 60°C

Output impedance: Min. 5 Kohm

Conversion time: 2 msec. / all channel

General Specifications

Power consumption: Max. 200 mA @ 5 VDC

Isolation: I/O to logic: 1K VDC galvanic isolation

Wiring: I/O cable max. AWG14

Conversion Table (M-4210)

Voltage	0V	2V	5V	10V
Data (Hex)	H0000	H0333	H07FF	H0FFF

Conversion Table (M-4211)

Voltage	-10V	-5V	0V	5V	10V
Data (Hex)	HF800	HFC00	H0000	H3FFF	H07FF

Conversion Table (M-4212)

Voltage	0V	2V	4V	5V
Data (Hex)	H0000	H0666	H0CCC	H0FFF



System Modules

When to Use a System Module

Power expansion module

The system power expansion module is designed to provide extra power for connected I/O expansion modules. Each network adapter can provide 1.5 Amp/5 VDC. When the overall I/O expansion module exceeds this limitation, you will need to use an M-7001 module. However, please note that M-7001 can only provide 1 Amp per 5 VDC.

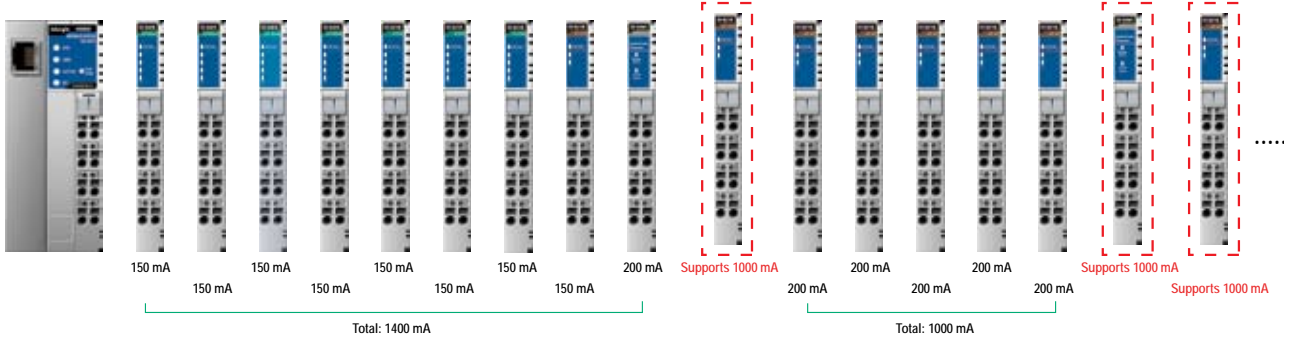

Field Power Distributor Module

The field power distributor is designed to isolate different field voltages. For example, before you connect a 48 VDC or 110 VAC I/O module to a 24 VDC I/O module, you will need an M-7002 Field power distributor.

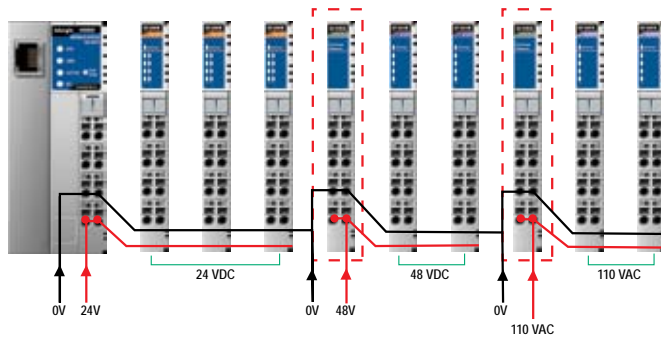

Potential Distributor Module

Three kinds of Potential Distributor Module provide extra wiring points, such as shielding ground, 0V field power, and 24V field power. For example, the 8-channel digital input (sink type) module by itself does not have a 24V wiring point. You may add an M-7805 for easier wiring.

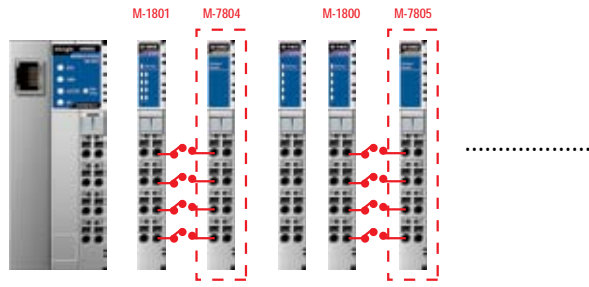



System Modules

System Power Module

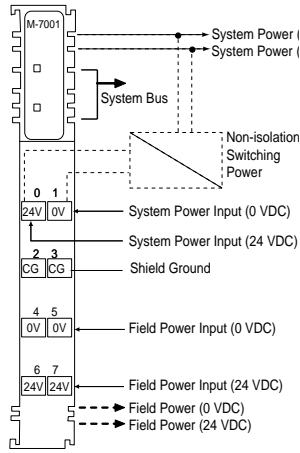

M-7001 System power expansion, 1.0A / 5 VDC

Input Specifications

System input voltage range: 11 to 28.8 VDC

System power input voltage: Nominal 24 VDC

Field power input voltage: Nominal 24 VDC (+/-20%)

Output Specifications

System bus output voltage: Max. 5 VDC

Field power contacts current: Max. 10A

Wiring: I/O cable max. AWG14

The system power expansion module is designed to provide extra power for connected I/O expansion modules.

When the overall I/O expansion module exceeds 1.5 Amp/ 5 VDC, you will need to use an M-7001 module.

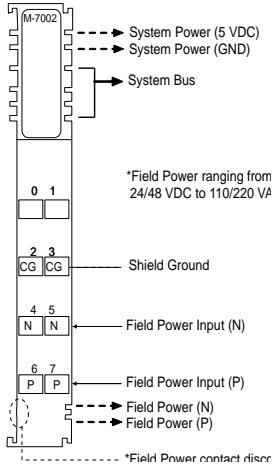

M-7002 Field power distributor

Input Specifications

Field power voltage: 5 VDC, 24 VDC, 48 VDC, 110 VAC, 220 VAC

Output Specifications

Field power contacts current: Max. 10A

Wiring: I/O cable max. AWG14

The field power distributor is designed to isolate different field voltages. For example, before you connect a 48 VDC or 110 VAC D/I/O module to a 24 VDC D/I/O module, you will need an M-7002 field power distributor.

System Modules

System Power Module

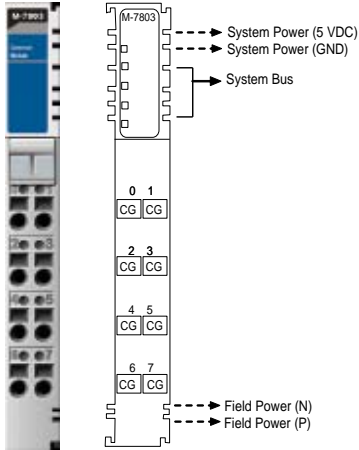

M-7803 Potential distributor, 8-ch, shield signal

Input Specifications

Field power voltage: Shield signal

Output Specifications

Field power contacts current: Max. 10A

Wiring: I/O cable max. AWG14

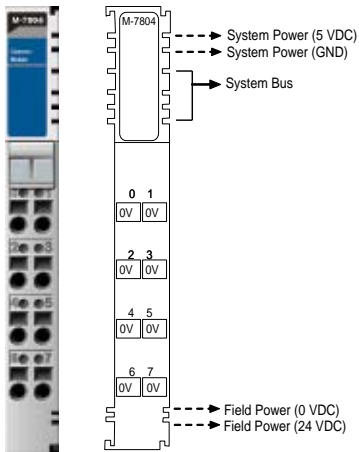

M-7804 Potential distributor, 8-ch, 0 VDC

Input Specifications

Field power voltage: 0 VDC

Output Specifications

Field power contacts current: Max. 10A

Wiring: I/O cable max. AWG14

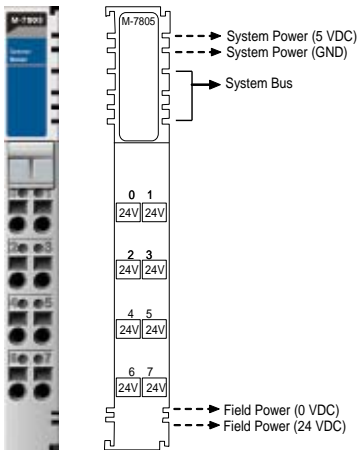

M-7805 Potential distributor, 8-ch, 24 VDC

Input Specifications

Field power voltage: 24 VDC

Output Specifications

Field power contacts current: Max. 10A

Wiring: I/O cable max. AWG14



System Modules

System Power Module

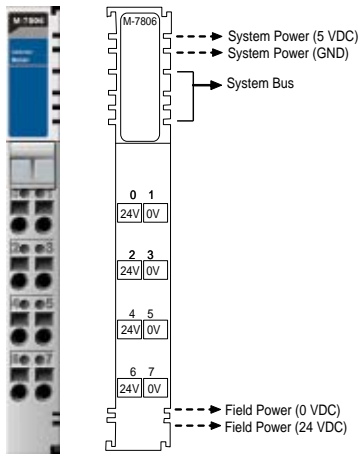

M-7806 Potential distributor, 4-ch/24 VDC, 4-ch/0 VDC

Input Specifications

Field power voltage: 24 VDC/0 VDC

Output Specifications

Field power contacts current: Max. 10A

Wiring: I/O cable max. AWG14

General Specifications

Environmental Specifications	
Operating Temperature	-20 to 60°C (Discrete I/O) 0 to 60°C (Analog I/O)
Non-Operating Temperature	-40 to 85°C
Relative Humidity	5 to 90% Non-condensing
Operating Altitude	2,000 m
Mounting	DIN-Rail
General Specifications	
Wiring I/O Cable	I/O Cable Max. 2.0m2 (AWG 14)
Shock (Operating)	2G
Shock (Non-Operating)	30G
Protect. Class	IP20
Product Certifications	UL 508, CE
Isolation	DC Module (Includes Analog Module): Terminal Block to F.G 500 VAC/1 min AC Module: Terminal Block to F.G 1500 VAC/1 min Relay Module: Terminal lock to F.G 2500 VAC/1 min
Gross Weight	Network Adapter: 180g I/O Modules: 70g
Waranty	2 years

Ordering Information

Model No.	Network Adapter
NA-4010	Ethernet Network Adapter Modbus/TCP
NA-4020	RS-485 Network Adapter Modbus/RTU
NA-4021	RS-232 Network Adapter Modbus/RTU
Model No.	Digital Input
M-1400	4 DI, Sink, 24 VDC, RTB
M-1401	4 DI, Source, 24 VDC, RTB
M-1410	4 DI, Sink, 48 VDC, RTB
M-1411	4 DI, Source, 48 VDC, RTB
M-1800	8 DI, Sink, 24 VDC, RTB
M-1801	8 DI, Source, 24 VDC, RTB
M-1600	16 DI, Sink, 24 VDC, 20-pin
M-1601	16 DI, Source, 24 VDC, 20-pin
M-1450	4 DI, 110 VAC, RTB
M-1451	4 DI, 220 VAC, RTB
Model No.	Digital Output
M-2400	4 DO, Sink, MOSFET, 24 VDC, 0.5A, RTB
M-2401	4 DO, Source, MOSFET, 24 VDC, 0.5A, RTB
M-2800	8 DO, Sink, MOSFET, 24 VDC, 0.5A, RTB
M-2801	8 DO, Source, MOSFET, 24 VDC, 0.5A, RTB
M-2600	16 DO, Sink, MOSFET, 24 VDC, 0.3A, 20-pin
M-2601	16 DO, Source, MOSFET, 24 VDC, 0.3A, 20-pin
M-2402	4 DO, Sink, MOSFET, self-diagnostics, 24 VDC, 0.5A, RTB
M-2403	4 DO, Source, MOSFET, self-diagnostics, 24 VDC, 0.5A, RTB
M-2404	4 DO, Sink, MOSFET, self-diagnostics, 24 VDC, 2.0A, RTB
M-2405	4 DO, Source, MOSFET, self-diagnostics, 24 VDC, 2.0A, RTB
M-2250	2 DO, Relay, 230 VAC, 24 VDC, 2.0A, RTB
M-2254	2 DO, Triac, 12 to 125 VAC, 0.5A, RTB

*RTB: Removable Terminal Block

*20-pin: 20-pin header

Model No.	Analog Input
M-3400	4 AI, Current, 0 to 20 mA, single-ended, 12-bit, RTB
M-3402	4 AI, Current, 4 to 20 mA, single-ended, 12-bit, RTB
M-3410	4 AI, Voltage, 0 to 10V, single-ended, 12-bit, RTB
M-3412	4 AI, Voltage, -10 to 10V, single-ended, 12-bit, RTB
M-3414	4 AI, Voltage, 0 to 5V, single-ended, 12-bit, RTB
M-3401	4 AI, Current, 0 to 20 mA, single-ended, 14-bit, RTB
M-3403	4 AI, Current, 4 to 20 mA, single-ended, 14-bit, RTB
M-3411	4 AI, Voltage, 0 to 10V, single-ended, 14-bit, RTB
M-3413	4 AI, Voltage, -10 to 10V, single-ended, 14-bit, RTB
M-3415	4 AI, Voltage, 0 to 5V, single-ended, 14-bit, RTB
M-6200	2 AI, RTD, PT100, JPT100, RTB
M-6201	2 AI, Thermocouple: 30 mV (1V/bit), RTB
Model No.	Analog Output
M-4201	2 AO, Current, 0 to 20 mA, 12-bit, RTB
M-4202	2 AO, Current, 4 to 20 mA, 12-bit, RTB
M-4210	2 AO, Voltage, 0 to 10V, 12-bit, RTB
M-4211	2 AO, Voltage, -10 to 10V, 12-bit, RTB
M-4212	2 AO, Voltage, 0 to 5V, 12-bit, RTB
Model No.	System Modules
M-7001	System expansion power supply, 1.0A (5 VDC)
M-7002	Field power distributor, 10A (24/48 VDC, 110/220 VAC)
M-7803	Potential distributor, 8-ch, Shield signal
M-7804	Potential distributor, 8-ch, 0 VDC
M-7805	Potential distributor, 8-ch, 24 VDC
M-7806	Potential distributor, 4-ch/24 VDC, 4-ch/0 VDC, Potential
M-8001-PK	Removable terminal block, 9 pcs per pack
M-8003-PK	Marker with 0-9 numbering, color, 100 pcs
M-8004-PK	Blank marker, 100 pcs

