

UC-8416 Series

RISC-based industrial embedded computers with 8 serial ports, 3 LANs, DIO, 8 built-in Ethernet switch ports, CompactFlash, USB



- > Intel XScale IXP435 533 MHz processor
- > 256 MB DDR2 SDRAM and 16 MB Flash ROM onboard
- > 32 MB NAND Flash for data storage
- > 256 KB battery backup SRAM
- > 8 RS-232/422/485 serial ports
- > 8 Ethernet switch ports
- > 4 digital input and 4 digital output channels
- > 3 10/100 Mbps Ethernet ports
- > 2 USB 2.0 hosts for mass storage devices
- > CompactFlash socket for storage expansion
- > Ready-to-run Linux platform
- > DIN-Rail or wall mounting installation
- > Robust, fanless design
- > -40 to 75°C wide temperature model available

The certification logos shown here apply to some or all of the products in this section. For details, see "Regulatory Approvals" under "Specifications" below.



Overview

The UC-8416 embedded computer comes with 8 RS-232/422/485 serial ports, 3 Ethernet ports, 8 Ethernet switch ports, 4 digital input channels, 4 digital output channels, a CompactFlash socket, and 2 USB 2.0 hosts.

The computer uses the Intel XScale IXP435 533 MHz RISC CPU. This powerful computing engine supports several useful communication functions, but will not generate too much heat. The built-in 16 MB NOR Flash ROM and 256 MB SDRAM give you enough memory to run your application software directly on the UC-8410, and the 32 MB NAND Flash can be used to provide additional data storage. Moreover, the 256 KB SRAM offers a better data retention mechanism for avoiding data loss.

The UC-8416 computer comes with 8 RS-232/422/485 serial ports, digital I/O, and has 3 LAN ports and 8 Ethernet switch ports, making it ideal as a communication platform for industrial applications that require network redundancy.

The UC-8416 comes with the Linux 2.6 platform pre-installed to provide an open software operating system for software program development. Software written for a desktop PC can be easily ported to the UC-8416 platform by using a common compiler, without needing to modify the code. This makes the UC-8416 an optimal solution for use with industrial applications, but with minimal cost and effort.

In addition to the standard model, the UC-8416 also comes in a -40 to 75°C wide temperature model for harsh industrial environments.

Appearance

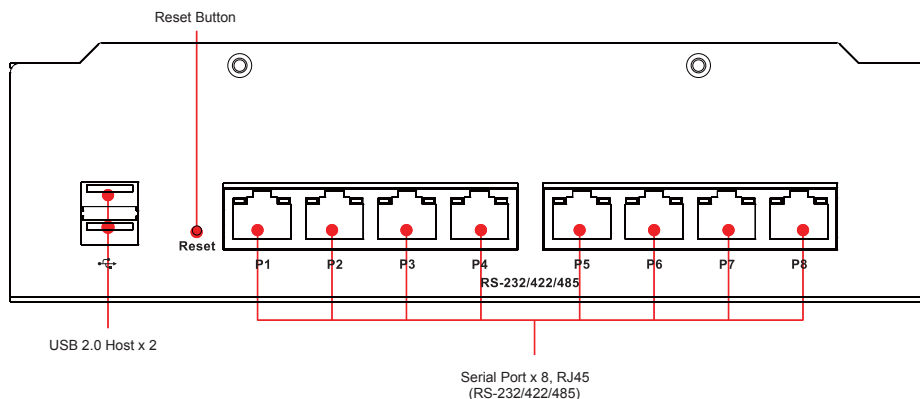

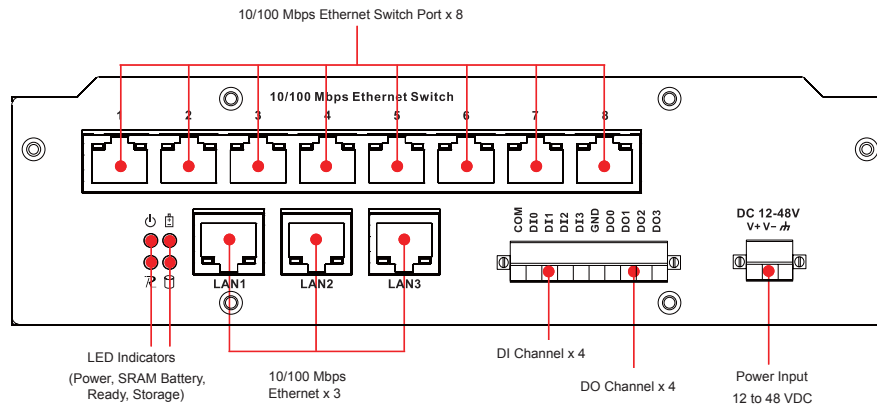

Hardware Specifications

Computer

CPU: Intel XScale IXP435, 533 MHz

OS (pre-installed): Linux

DRAM: 256 MB DDR2 SDRAM onboard (supports DDR2 up to 512 MB)

SRAM: 256 KB, battery backup

Flash:

16 MB NOR Flash onboard to store OS (supports up to 32 MB)

32 MB NAND Flash onboard to store data

USB: USB 2.0 full speed x 2 (OHCI)

Storage

Storage Expansion: CompactFlash socket

Ethernet Interface

LAN: 3 auto-sensing 10/100 Mbps ports (RJ45)

Switch Ports: 8 10/100 Mbps unmanaged ports

Magnetic Isolation Protection: 1.5 KV built-in

Serial Interface

Serial Standards: 8 RS-232/422/485 ports, software-selectable (8-pin RJ45)

Console Port: RS-232 (TxD, RxD, GND), 4-pin header output (115200, n, 8, 1)

Serial Communication Parameters

Data Bits: 5, 6, 7, 8

Stop Bits: 1, 1.5, 2

Parity: None, Even, Odd, Space, Mark

Flow Control: RTS/CTS, XON/XOFF, ADDC® (automatic data direction control) for RS-485

Baudrate: 50 bps to 921.6 Kbps (supports non-standard baudrates; see user's manual for details)

Serial Signals

RS-232: TxD, RxD, DTR, DSR, RTS, CTS, DCD, GND

RS-422: TxD+, TxD-, RxD+, RxD-, GND

RS-485-4w: TxD+, TxD-, RxD+, RxD-, GND

RS-485-2w: Data+, Data-, GND

Digital Input

Input Channels: 4, source type

Input Voltage: 0 to 30 VDC

Digital Input Levels for Dry Contacts:

- Logic level 0: Close to GND
- Logic level 1: Open

Digital Input Levels for Wet Contacts:

- Logic level 0: +3 V max.
- Logic level 1: +10 V to +30 V (COM to DI)

Connector Type: 10-pin screw terminal block (4 points, COM, GND)

Isolation: 3 KV optical isolation

Digital Output

Output Channels: 4, sink type

Output Current: Max. 200 mA per channel

On-state Voltage: 24 VDC nominal, open collector to 30 V

Connector Type: 10-pin screw terminal block (4 points, GND)

Isolation: 3 KV optical isolation

LEDs

System: Power, Ready, Storage, Battery for SRAM

LAN: 10M/Link x 2, 100M/Link x 2 (on connector)

Serial: TxD x 8, RxD x 8

Reset Button: Supports "Reset to Factory Default"

Physical Characteristics

Housing: SECC sheet metal (1 mm)

Weight: 930 g

Dimensions: 200 x 56 x 120 mm (7.87 x 2.20 x 4.72 in)

Mounting: DIN-Rail, wall

Environmental Limits

Operating Temperature:

Standard Models: -10 to 60°C (14 to 140°F)

Wide Temp. Models: -40 to 75°C (-40 to 167°F)

Operating Humidity: 5 to 95% RH

Storage Temperature:

Standard Models: -20 to 80°C (-4 to 176°F)

Wide Temp. Models: -40 to 85°C (-40 to 185°F)

Anti-vibration: 1g @ IEC-68-2-6, sine wave, 5-500 Hz, 1 Oct./min, 1 hr/axis

Anti-shock: 5g @ IEC-68-2-27, half sine wave, 30 ms

Power Requirements

Input Voltage: 12 to 48 VDC (3-pin terminal block)

Power Consumption: 15 W

• 300 mA @ 48 V

• 625 mA @ 24 VDC

• 1280 mA @ 12 V

Regulatory Approvals

EMC: CE (EN55022 Class B, EN55024-4-2, EN55024-4-3, EN55024-4-4), FCC (Part 15 Subpart B, Class B)

Safety: UL/cUL (UL60950-1), CCC (GB9254, GB 17625.1), LVD (EN60950)

Reliability

Alert Tools: Built-in buzzer and RTC (real-time clock)

Automatic Reboot Trigger: Built-in WDT (watchdog timer)

Warranty

Warranty Period: 5 years

Details: See www.moxa.com/warranty

Note: The Hardware Specifications apply to the embedded computer unit itself, but not to accessories. In particular, the wide temperature specification does not apply to accessories such as the power adaptor and cables.

Software Specifications

Linux

Kernel Version: 2.6.23

Protocol Stack: TCP, UDP, IPv4, SNMP V1, ICMP, ARP, HTTP, CHAP, PAP, SSH 1.0/2.0, SSL, DHCP, NTP, NFS, Telnet, FTP, PPP, PPPoE, OpenVPN

File System: JFFS2, NFS, Ext2, Ext3, VFAT/FAT

System Utilities: bash, busybox, tinylogin, telnet, ftp, ssh, scp

telnetd: telnet Server daemon

ftpd: FTP server daemon

sshd: secure shell server

Apache: web server daemon, supporting PHP and XML

openvpn: virtual private network service manager

pppd: dial in/out over serial port daemon

snmpd: snmpd agent daemon

openssl: open SSL

Application Development Software: Moxa Linux API device control

Linux Tool Chain:

- GCC (V4.2.1): C/C++ PC Cross Compiler

- Glibc (V2.2.5): POSIX standard C Library

- GDB (V6.3): source level debug server

Dimensions (unit = mm)

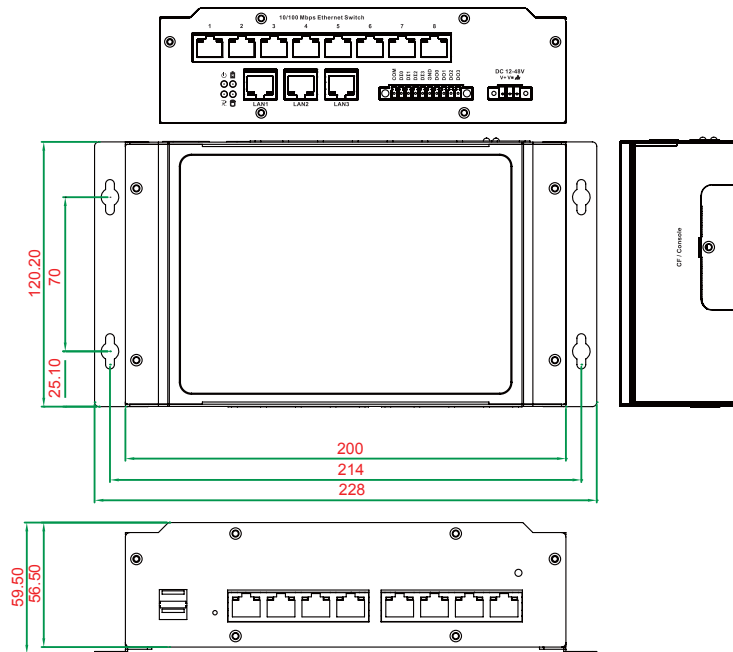

Ordering Information

Available Models

UC-8416-LX: RISC-based industrial embedded computer with 8 serial ports, 4 DIs, 4 DOs, 3 LANs, 8 switch ports, CompactFlash, USB, Linux OS, -10 to 60°C operating temperature

UC-8416-T-LX: RISC-based industrial embedded computer with 8 serial ports, 4 DIs, 4 DOs, 3 LANs, 8 switch ports, CompactFlash, USB, Linux OS, -40 to 75°C operating temperature

Package Checklist

- UC-8416 computer
- Wall mounting kit
- DIN-Rail mounting kit
- Ethernet cable: RJ45 to RJ45 cross-over cable, 100 cm
- CBL-4PINDB9F-100: 4-pin pin header to DB9 female console port cable, 100 cm
- Universal Power Adaptor (including power jack converter)
- Document and Software CD
- Quick Installation Guide (printed)
- Warranty Card