



Video Networking Solutions

Product Selection Guides

Industrial Video Networking Solutions 6-2

Video Networking Products

Introduction to Industrial Video Networking Solutions 6-3

VPort 354 Series Full motion, 4-channel MJPEG/MPEG4 industrial video encoders . . . 6-7

VPort 254 Series Rugged 4-channel MJPEG/MPEG4 industrial video encoders 6-10

VPort 351 Series Full motion, 1-channel MJPEG/MPEG4 industrial video encoders . . 6-13

VPort 3310 Series Rugged 1-channel MPEG4 industrial video servers (encoders) . . . 6-16

VPort 2141 Compact, 4-channel MJPEG video server (encoder) 6-18

VPort 251 Full motion, 1-channel MJPEG/MPEG4 video encoder 6-20

VPort D351 1-channel MJPEG/MPEG4 industrial video decoder 6-22

VPort 25 Series IP66, day-and-night fixed dome outdoor IP camera 6-24

SoftNVR Expandable, 64-channel IP surveillance software 6-27

SoftDVR™ Pro Easy-to-use 16-channel IP surveillance software 6-30

VPort SDK PLUS User-friendly software development kits 6-32

6

Video Networking Solutions



Video Networking Products



	VPort 354	VPort 254	VPort 351	VPort 3310	VPort 2141	VPort 251	VPort D351	VPort 25
Type of Product	Encoder	Encoder	Encoder	Encoder	Encoder	Encoder	Decoder	IP Camera
Form Factor								
Protection Rating	IP30	IP30	IP30	IP30	---	---	IP30	IP66
DIN-Rail Mounting	√	√	√	√	w/ optional Kit	w/ optional Kit	√	---
Panel Mounting	w/ optional Kit	w/ optional Kit	w/ optional Kit	w/ optional Kit	√	√	w/ optional Kit	---
Surface/Ceiling Mounting	---	---	---	---	---	---	---	√
Audio/Video Channels								
Video Inputs	4	4	1	1	4	1	0	0
Video Outputs	0	0	1	1	0	0	1	1
Audio Inputs	1	1	1	1	0	1	1	1
Audio Outputs	1	1	1	0	0	1	1	1
Compression Algorithm								
MJPEG	√	√	√	---	√	√	√	√
MPEG4	√	√	√	√	---	√	√	√
Video Performance								
QCIF (NTSC: 176 x 120)	30 FPS (max.)	---	---	30 FPS (max.)	30 FPS (max.)	---	---	---
QVGA (NTSC: 320 x 240)	---	30 FPS (max.)	30 FPS (max.)	---	---	30 FPS (max.)	---	30 FPS (max.)
CIF (NTSC: 352 x 240)	30 FPS (max.)	30 FPS (max.)	30 FPS (max.)	30 FPS (max.)	30 FPS (max.)	30 FPS (max.)	---	30 FPS (max.)
VGA (NTSC: 640 x 480)	---	7 FPS (max.)	30 FPS (max.)	10 FPS (max.)	---	30 FPS (max.)	---	30 FPS (max.)
2CIF (NTSC: 704 x 240)	30 FPS (max.)	---	---	---	---	---	---	---
4CIF (NTSC: 704 x 480)	30 FPS (max.)	7 FPS (max.)	30 FPS (max.)	10 FPS (max.)	30 FPS (max.)	30 FPS (max.)	---	30 FPS (max.)
Full D1 (NTSC: 720 x 480)	---	7 FPS (max.)	30 FPS (max.)	---	---	30 FPS (max.)	---	30 FPS (max.)
QCIF (PAL: 176 x 144)	25 FPS (max.)	---	---	25 FPS (max.)	25 FPS (max.)	---	---	---
QVGA (PAL: 320 x 288)	---	25 FPS (max.)	25 FPS (max.)	---	---	25 FPS (max.)	---	25 FPS (max.)
CIF (PAL: 352 x 288)	25 FPS (max.)	25 FPS (max.)	25 FPS (max.)	25 FPS (max.)	25 FPS (max.)	25 FPS (max.)	---	25 FPS (max.)
VGA (PAL: 640 x 576)	---	7 FPS (max.)	25 FPS (max.)	8 FPS (max.)	---	25 FPS (max.)	---	25 FPS (max.)
2CIF (PAL: 704 x 288)	25 FPS (max.)	---	---	---	---	---	---	---
4CIF (PAL: 704 x 576)	25 FPS (max.)	7 FPS (max.)	25 FPS (max.)	8 FPS (max.)	8 FPS (max.)	25 FPS (max.)	---	25 FPS (max.)
Full D1 (PAL: 720 x 576)	---	7 FPS (max.)	25 FPS (max.)	---	---	25 FPS (max.)	---	25 FPS (max.)
Quad View	---	---	---	---	15 FPS (max.)	---	---	---
Network Connections								
10/100BaseT(X) Ports	2	1	1	1	1	1	1	1
100BaseFX Ports	2	1	1	---	---	---	---	---
Number of COM Ports								
PTZ Ports	1	1	1	1	2	1	1	---
RS-232 Console Ports	1	1	1	---	---	1	1	---
Network Management and Control								
Web Browser	√	√	√	√	√	√	√	√
SNMP Protocols	v1/v2c/v3	v1/v2c/v3	v1/v2c/v3	v1/v2c/v3	---	v1/v2c/v3	v1/v2c/v3	v1/v2c/v3
RTSP (Real Time Streaming Protocol)	√	√	√	√	---	√	---	√
Multicast (IGMP)	v3	v3	v3	v3	---	v3	---	v3
QoS	√	√	√	---	---	√	---	√
UPnP	√	√	√	√	√	√	√	√
DDNS	√	√	√	√	√	√	√	√
PPPoE	---	---	---	√	√	---	---	---
IP Filtering	√	√	√	√	√	√	√	√
Power Requirements								
Power Redundancy	√	√	√	√	---	---	√	√
Power Inputs	2	2	2	2	1	1	2	1
Power Outputs	0	0	0	0	1	1	0	0
Power-over-Ethernet (PoE)	---	---	---	---	---	---	---	√
Alarms								
VMD (Video Motion Detection)	√	√	√	√	√	√	---	√
Digital Inputs	4	4	2	2	4	1	2	1
Relay (Digital) Outputs	2	2	2	2	4	1	2	1
Alarm Video Recording	√	---	√	---	---	---	---	---
Alarm Snapshot Image	√	√	√	√	√	√	---	√
Supported Operating Temperature Ranges								
0 to 60°C	√	√	√	√	√	√	√	---
-40 to 50°C	---	---	---	---	---	---	---	√
-40 to 75°C	√	√	√	√	---	---	---	---
Regulatory Approvals								
CE/FCC	√	√	√	√	√	√	√	√
UL508	Pending	√	√	---	---	---	√	Pending
Class 1, Div 2; ATEX Class 1, Zone 2	Pending	Pending	√	---	---	---	---	---

6

Video Networking Solutions > Product Selection Guides

Introduction to Industrial Video Networking

Empower Your Video Network System with Industrial-grade Reliability

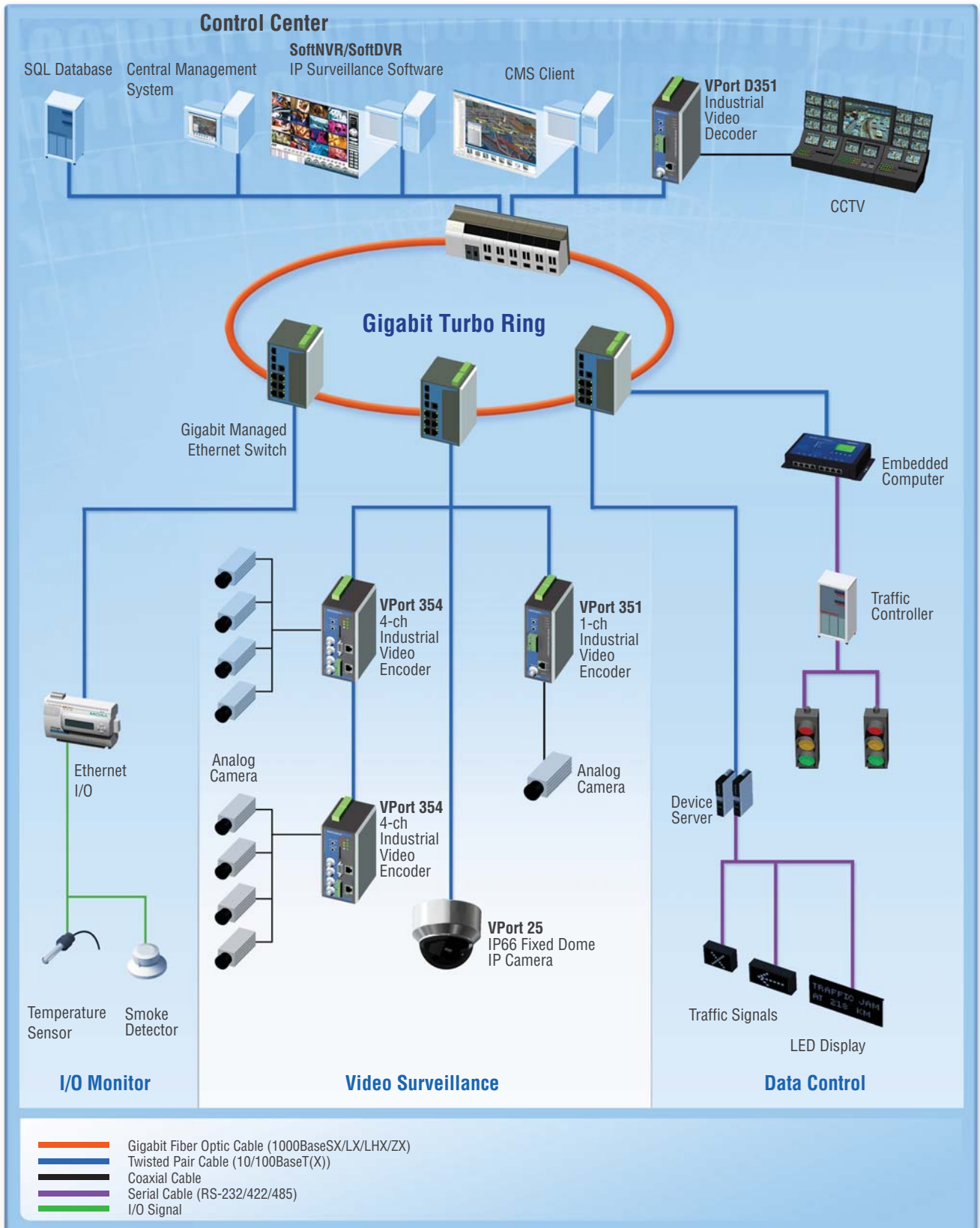

Leading the Industrial Video-over-IP Revolution

Thanks to the ever-increasing popularity of IP networks, transmitting video, voice, and data simultaneously over Ethernet networks, and even over the Internet, is now standard at locations around the world. Because of this, CCTV surveillance systems are also becoming more commonplace. Versatile and advanced video digitizing and compression technologies, such as MJPEG and MPEGx, make it possible to migrate CCTV surveillance systems to IP-based platforms. This means that video-over-IP solutions, which include IP cameras, video servers, and NVRs (Network Video Recorders), are used by some of the hottest products in the CCTV surveillance market. However, most video-over-IP solutions on the market today are designed for general purpose applications, which means they are not suitable for unpredictable industrial environments. In fact, some seemingly commonplace applications, such as road traffic control and monitoring, oil and gas refineries and pipelines, mining pits, etc., should be classified as industrial-grade, and as such require using rugged, well-designed video-over-IP solutions to ensure that the video surveillance system works properly.

To meet these stringent requirements, Moxa's new line of VPort industrial video-over-IP solutions feature an industrial-grade rugged design and extra-high reliability.



Integrated and Applicable Video Networking Solutions

Moxa's industrial video networking solutions include video servers and IP cameras that meet the requirements of a variety of application environments, such as transportation, utilities, factory monitoring, and automatic control systems. The video servers, which include video encoders and video decoders, are designed rugged to protect the hardware when it's used in demanding industrial environments. The IP camera, with vandal-proof protection and a high-quality day/night lens, is suitable for outdoor environments.

As a one-source provider, Moxa also provides a wide range of industrial Ethernet switches with redundant capability and high-performance Gigabit bandwidth for video networking infrastructures. This means that you can use Moxa's products to build a highly reliable video surveillance network for industrial automation applications.

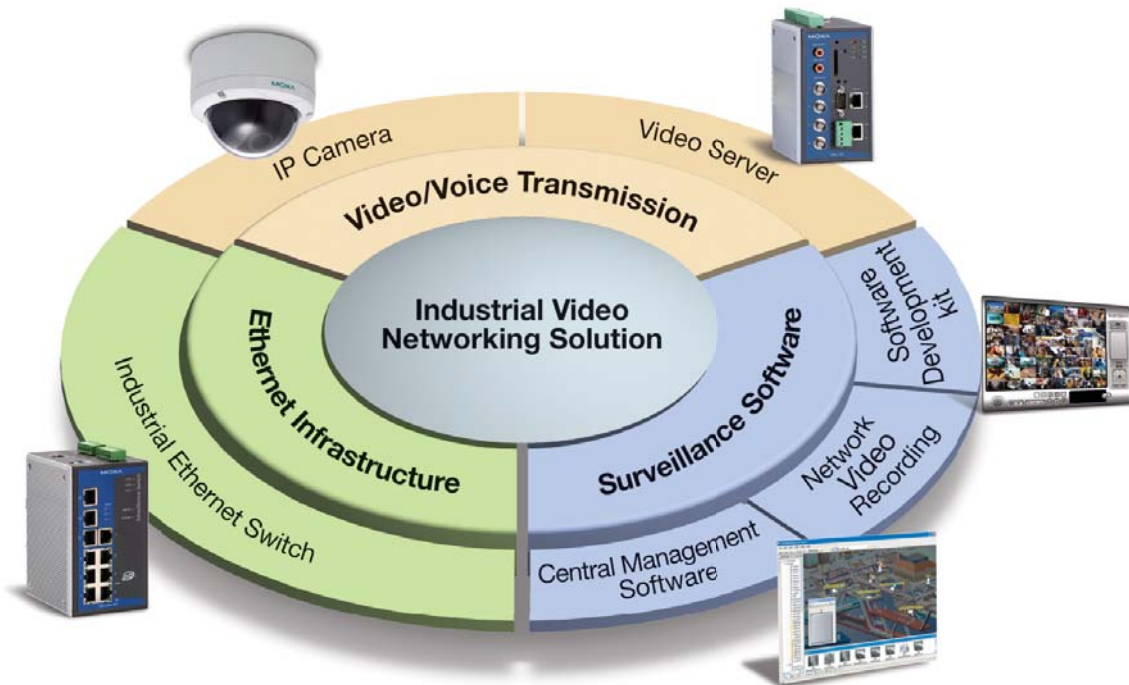

Industrial-grade Rugged Design and Reliability

Products used in industrial environments must have a rugged design to provide better protection against adverse conditions. In general, ruggedized products should have the following characteristics:

1. Power Redundancy

A backup power supply is required since power lines used in harsh industrial environments have a greater chance of failing. This means that industrial products should have at least 2 power inputs to provide sufficient redundancy.

2. Enclosure Protection

A rugged mechanism design means having good physical protection against unexpected damage from external factors. The Ingress Protection (IP) rating index (EN60529) is an international classification system that rates the effectiveness of sealing for enclosures of electrical equipment against the intrusion of foreign objects (e.g., tools, dust, fingers) and moisture. The IP rating system can be used to determine what kind of enclosure, if any, is required for the product.

3. EMI and Surge Protection

Compared to commercial-type environments, industrial environments are more likely to be subjected to severe electrical and magnetic influences. In order to protect electronic devices, higher EMI and surge protection are essential for industrial

applications. And for some industrial applications, safety approvals and demanding certifications, such as UL508 and ATEX (ATmosphere EXplosible), are also required.

4. High MTBF (Mean Time Between Failures)

The MTBF value is the “mean time between failures” for a device. A higher MTBF value indicates that a device is more reliable.

5. Wide Operating Temperature Range

The operating temperature range is also a key issue for industrial products. In fact, some industrial applications require products that are guaranteed to operate in temperatures ranging from as low as -40°C to as high as 75°C. For these types of applications, it is important to look for products that do not use a built-in fan, since products with fans tend to have a lower MTBF.

6. DIN-Rail Mounting and Panel Mounting

A 35 mm DIN-Rail is used for many industrial applications to provide a convenient means of mounting all of the devices used for the application. For this reason, it is essential that industrial products support both DIN-Rail mounting and panel mounting.

VPort Industrial Video Servers

- 12/24 VDC or 24 VAC redundant power inputs
- DIN-Rail mounting and panel mounting accessories available
- IP30 protection enclosure
- -40 to 75°C operating temperature range for T models
- Choose either RJ45 or fiber optic Ethernet ports
- Industrial EMI/ESD protection and UL508, ATEX Class 1 Div. 2 and DNV certifications

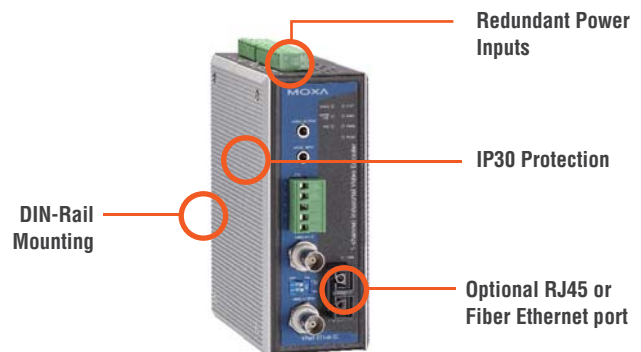

VPort Series IP Cameras

- -40 to 50°C operating temperature, heater or fan NOT required
- IP66-rated for protection from rain and dust
- PoE (Power-over-Ethernet) and direct-wired power supply for power redundancy
- Vandal-proof form factor for preventing damage from unexpected external forces
- Versatile installation options for outdoor environments



Advanced Network Capability for Efficient Video Transmissions

Moxa's VPort series industrial video encoders allow customers to deploy video surveillance network systems with better network management parameters for high-performance video transmissions. By supporting the Modus/TCP protocol, users can seamlessly integrate Moxa's video solutions with SCADA/HMI systems. Several advanced

network functions include RSTP video streaming for easy integration, IGMP protocols for efficient network transmission, QoS to increase the determinism of the video stream, and SNMP for easy network management.

▶ User-friendly Video-over-IP Surveillance Software for Application Versatility

In addition to video transmission and Ethernet infrastructure products, Moxa also provides video surveillance software solutions for building an IP video surveillance system. These software solutions contain NVR (network video recording) software that supports from 4 to 64 channels, plus CMS (central management system) software for managing multiple NVR systems, making it possible to manage much larger systems made up of an unlimited number of cameras.

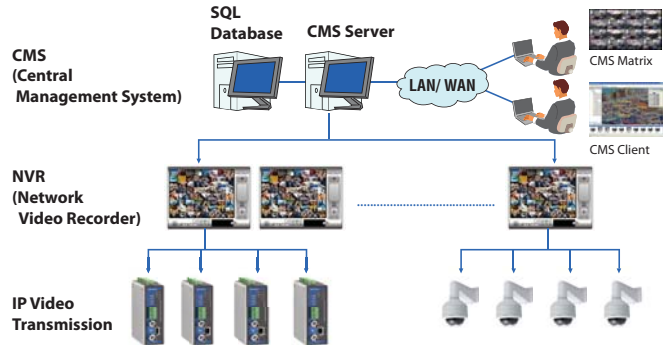

6

Video Networking Solutions > Introduction to Industrial Video Networking

SoftNVR

Expandable network video recording software for managing up to 64 channels of video cameras.



- Multi-screen viewing format
- Dual monitor capability
- Video analytics and instant response
- Video quality enhancement tools
- Intelligent and convenient video search

SoftDVR

Standalone network video recording software for managing up to 16 channels of video cameras.

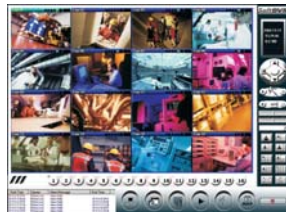

- Multi-screen viewing format
- Event-driven recording
- Search and playback are easy to use
- Store data to network hard disk
- Set schedule for recording and activating alarms
- Remote access by web browser

Free Software Development Kit for Third-party Software Developers and System Integrators

Most video surveillance systems require customized video management functions, or must be integrated with other applications, such as SCADA systems, access control systems, or fire alarm systems. For this reason, a user-friendly SDK (software development kit) is a good tool to have available for building customized video management systems. Moxa's VPort SDK PLUS, which includes CGI

Commands, ActiveX, and a C library, is available free of charge to system integrators and third-party software developers. Learning to use VPort SDK PLUS is easy, and detailed documentation and sample code is provided for quick reference. For detailed information about SDK PLUS, please refer to the "SDK" introduction in this catalog.

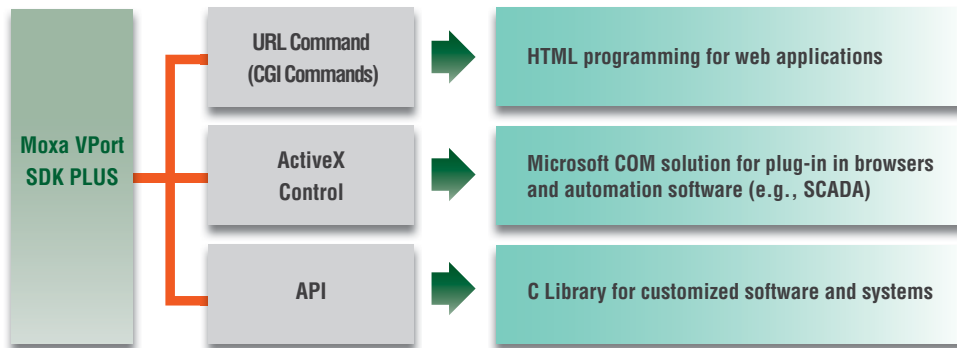

VPort 354 Series

Preliminary

Full motion, 4-channel MJPEG/MPEG4 industrial video encoders



- > Industrial design with -40 to 75°C operating temperature and fiber optic Ethernet port
- > 2 Ethernet ports for cascade and port redundancy
- > SD card slot for local storage capability
- > Modbus/TCP supported for easy communication with SCADA software
- > Video stream up to 120 frames/sec at 4CIF (704 x 480) resolution

The certification logos shown here apply to some or all of the products in this section. For details, see "Regulatory Approvals" under "Specifications" below.



Introduction

The VPort 354 is a high performance, 4-channel industrial video encoder that provides up to 4CIF full frame rate performance (NTSC: 704 x 480 @ 30 FPS; PAL: 704 x 576 @ 25 FPS) for each channel, and supports a dual MJPEG/MPEG4 algorithm, making it especially well-suited for use with distributed surveillance systems in critical industrial

applications. In addition, a continuous pre/post event trigger video record function can help system administrators determine why an alarm was triggered, and 2-way audio is provided for the convenience of real-time communication between system administrators located at the central site, and engineers in the field.

Rugged Design for Mission-critical Industrial Environments

- -40 to 75°C wide operating temperature
- Built-in single-mode or multi-mode fiber optic Ethernet port—media converter not required
- 2 Ethernet ports for cascade and port redundancy
- 1 RS-232/422/485 COM port for controlling external serial devices over Ethernet
- Redundant 12/24 VDC and 24 VAC power inputs for greater reliability
- Metal housing with IP30 protection against dust
- DIN-Rail mounting installation for industrial environments
- UL508 (Pending) and Class 1, Div. 2 (Pending) certified for hazardous locations
- Meets NEMA TS2, Section 2 requirements

Advanced Network Protocols Support Efficient Network Transmission and Integration

- Modbus/TCP for easy communication with SCADA software
- Standard RTSP (real-time streaming protocol) video streaming for easy integration
- Multicast (IGMP) protocols for efficient network transmission
- SNMPv1/v2c/v3 MIB-II for easy network management
- QoS (ToS) for configuring the transmission priority of video streams
- UPnP, DDNS, and IP filtering supported

Two Ethernet Ports for Cascading and Port Redundancy

The VPort 354 has two built-in 10/100 Mbps Ethernet ports for cascading multiple VPort 354 units. With the cascade feature, you'll need fewer switch ports, and also reduce your cable layout effort. An Ethernet by-pass function is also supported so that the cascade link will keep working if one of the VPort 354 units in the cascade chain goes offline. Port redundancy can be used to build a backup path for video transmission in case the primary path is broken.

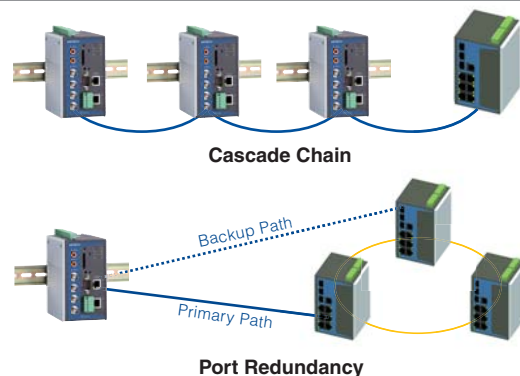

SD Card for Storing Video Locally when the Network is Down

The VPort 354 is equipped with an SD card socket (V2.0) for local storage purposes. Enable local storage to record events that occur

when the network is down and the video stream cannot be transmitted.

Transparent PTZ Control for Easy Control of PTZ Cameras

The VPort 354 uses Moxa's Real COM technology to implement transparent communication for RS-232/422/485 PTZ control. The benefit of the Transparent PTZ Control function is that it eliminates the need to build the PTZ control driver into the VPort product, allowing the use of a legacy PTZ control panel or keyboard to control a PTZ camera directly.

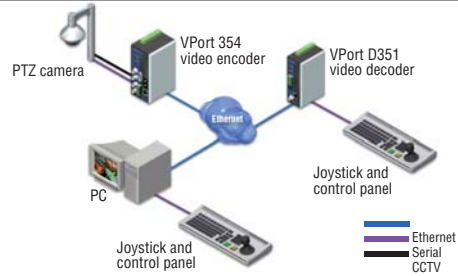

Specifications

Video

Video Compression: MJPEG or MPEG4 (ISO/IEC 14496-2)

Video Stream: Dual streams (one for MJPEG, the other for MPEG4) at the same video resolution (note that MJPEG only has one quality setting)

Video Inputs: 4, BNC connector (1.0 Vpp, 75 ohms)

NTSC/PAL: Auto-sensing or manual

Video Resolution and FPS (frames per second):

	NTSC		PAL	
	Size	Max. FPS	Size	Max. FPS
QCIF	176 x 120	30	176 x 144	25
CIF	352 x 240	30	352 x 288	25
2CIF	704 x 240	30	704 x 288	25
4CIF	704 x 480	30	704 x 576	25

Video Viewing:

- Adjustable image size and quality
- Timestamp and text overlay

Video Output: Via Ethernet port

Audio

Audio Inputs: 1 Line-in or MIC-in with RCA connector

Audio Outputs: 1 Line-out with RCA connector

Network

Protocols: TCP, UDP, HTTP, SMTP, FTP, Telnet, NTP, DNS, DHCP, UPnP, RTP, RTSP, ICMP, IGMPv3, QoS, SNMPv1/v2c/v3, DDNS

Ethernet: 2 10/100BaseT(X) auto negotiating RJ45 ports, or 2 100BaseFX fiber ports (single/multi-mode, SC connector)

Optical Fiber:

	100BaseFX	
	Multi-mode	Single-mode
Wavelength	1300 nm	1310 nm
Max. TX	-10 dBm	0 dBm
Min. TX	-20 dBm	-5 dBm
RX Sensitivity	-32 dBm	-34 dBm
Link Budget	12 dB	29 dB
Typical Distance	5 km ^a 4 km ^b	40 km ^c
Saturation	-6 dBm	-3 dBm

a. 50/125 μm, 800 MHz*km fiber optic cable

b. 62.5/125 μm, 500 MHz*km fiber optic cable

c. 9/125 μm single-mode fiber optic cable

Serial Port

PTZ Ports: 1, RS-232/422/485 port (terminal block connector), max. speed of 115.2 Kbps, with 15 KV ESD protection

COM Ports: 1, RS-232/422/485 (DB9 female connector), max. speed of 115.2 Kbps, with 15 KV ESD protection

Console Port: 1 RS-232 RJ45 port

GPIO

Digital Inputs: 4, max. 8 mA

- High: +13 to +30V
- Low: -30 to +3V

Relay Outputs: 2, max. 24 VDC @ 1 A

LED Indicators

STAT: Indicates if the system booted properly or not

PWR1: Power 1

PWR2: Power 2

FAULT: Can be configured to correspond to system alarm, power failure, video loss, or disconnected network

V1, V2, V3, V4: Video input signal activity

Local Storage

SD Socket: Standard SD socket, V2.0, with SD LED indicator

Power Requirements

Input Voltage: 2 12/24 VDC or 24 VAC inputs for redundancy

Power Consumption: Approx. 12 W

Physical Characteristics

Housing: Metal, IP30 protection

Dimensions: 80.2 x 135 x 105 mm (3.16 x 5.31 x 4.13 in)

Weight: 1200 g

Installation: DIN-Rail mounting, wall mounting (with optional kit)

Alarms

Pre/Post Alarm: 9 MB memory for video recordings

Video Motion Detection: Includes sensitivity tuning

Video Loss: Video loss alarm

Scheduling: Daily repeat timing schedule

Imaging: JPEG snapshots for pre/trigger/post alarm images

Email/FTP Messaging: Automatic transfer of stored images via email or FTP with event-triggered actions

Custom Alarms: HTTP event servers for setting customized alarm actions

PAN/TILT/ZOOM

PTZ Camera Control: Via RS-232/422/485 PTZ port or COM port

PTZ Control Functions: PAN, TILT, ZOOM, FOCUS, moving speed, preset position (max. 25 positions), and 10 custom commands

PTZ Function Updates: Driver upload supported

Supported Devices and Protocols: Pelco D, Pelco P, Dynacolor DynaDome, Custom Camera

Transparent PTZ Control: Control PTZ cameras with legacy PTZ control panel or keyboard connected to a PC or VPort decoder

Security

Password: User level password protection

Filtering: By IP address

Environmental Limits

Operating Temperature:

Standard Models: 0 to 60°C (32 to 140°F)

Wide Temp. Models: -40 to 75°C (-40 to 167°F)

Storage Temperature: -40 to 85°C (-40 to 185°F)
Ambient Relative Humidity: 5 to 95% (non-condensing)

Regulatory Approvals

Safety: UL508 (Pending)

EMS:

- EN61000-4-2 (ESD), level 2
- EN61000-4-3 (RS), level 3
- EN61000-4-4 (EFT), level 3
- EN61000-4-5 (Surge), level 3
- EN61000-4-6 (CS), level 3
- EN61000-4-12 (Oscillatory wave immunity), level 3

EMI: FCC Part 15, CISPR (EN55022) class A

Hazardous Location: UL/cUL Class I, Division 2, Groups A, B, C and D (Pending); ATEX Class I, Zone 2, Ex nC IIC (Pending)

Traffic Control: NEMA TS2

Shock: IEC 60068-2-27

Freefall: IEC 60068-2-32

Vibration: IEC 60068-2-6

Note: Please check Moxa's website for the most up-to-date certification status.

Warranty

Warranty Period: 5 years

Details: See www.moxa.com/warranty

System Requirements

CPU: Pentium 4, 2.4 GHz or above

Memory: 512 MB memory or above

OS: Windows XP/2000 with SP2 or above

Browser: Internet Explorer 6.x or above

Multimedia: DirectX 9.0c or above

Software Bundled Free

SoftDVR™ Lite: 1 to 4-ch IP surveillance software for viewing and recording

VPort SDK PLUS: Includes CGI commands, ActiveX Control, and API library for customized applications or system integration for third-party developers (the latest version of SDK is available for download from Moxa's website).

Dimensions (unit = mm)

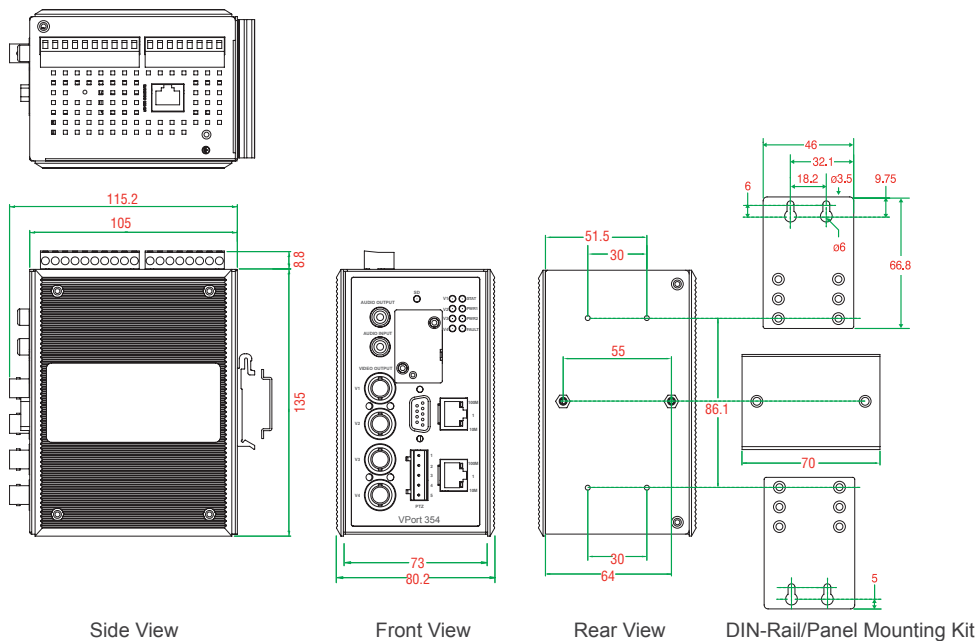

Ordering Information

Available Models		Port Interface		
Standard Temperature (0 to 60°C)	Wide Temperature (-40 to 75°C)	10/100BaseT(X)	Multi-mode, SC Connector	Single-mode, SC Connector
VPort 354	VPort 354-T	2	---	---
VPort 354-MM-SC	VPort 354-MM-SC-T	---	2	---
VPort 354-SS-SC	VPort 354-SS-SC-T	---	---	2

Optional Accessories (can be purchased separately)

SoftNVR: Expandable IP surveillance software for managing up to 64 video channels

SoftDVR™ Pro: 16-channel IP surveillance software for viewing and recording

DR-4524/75-24/120-24: 45/75/120 W DIN-Rail 24 VDC power supplies

MDR-40-24/60-24: 40/60 W DIN-Rail 24 VDC power supplies, -20 to 70°C operating temperature

WK-46: Wall mounting kit

RK-4U: 4U-high 19" rack mounting kit

VPort 254 Series

Rugged 4-channel MJPEG/MPEG4 industrial video encoders



- > Industrial design with -40 to 75°C operating temperature and fiber optic Ethernet port
- > Video stream up to 120 frames/sec at CIF (352 x 240) resolution
- > Modbus/TCP supported for easy communication with SCADA software
- > One RS-232/422/485 COM port for controlling external serial devices over Ethernet
- > Free VPort SDK PLUS and 4-channel video surveillance software

The certification logos shown here apply to some or all of the products in this section. For details, see "Regulatory Approvals" under "Specifications" below.



Introduction

The rugged VPort 254 is a 4-channel industrial video encoder that provides up to 120 FPS at CIF resolution (NTSC: 352 x 240; PAL: 352 x 288), and supports an optional MJPEG/MPEG4 algorithm, making it especially well suited for use with distributed surveillance systems in critical industrial applications. In addition, the VPort 254 supports

serial-to-Ethernet and Modbus/TCP communications for integrating automation systems, and 2-way audio is provided to allow real-time communication between system administrators located at a central site and engineers in the field.

Rugged Design for Mission-critical Industrial Environments

- Operates reliably in -40 to 75°C environments
- Built-in single-mode or multi-mode fiber optic Ethernet port (media converter not required)
- More reliable with redundant 12/24 VDC and 24 VAC power inputs

- Metal form factor with IP30 protection against dust
- DIN-Rail mounting installation suitable for industrial environments
- UL508 certified for industrial environments

Advanced Network Protocols for Efficient Network Transmission and Integration

- Modbus/TCP for easy communication with SCADA software
- Standard RTSP (real-time streaming protocol) video streaming for easy integration
- Multicast (IGMP) protocols for efficient network transmission

- SNMPv1/v2c/v3 MIB-II for easy network management
- QoS (ToS) for configuring the transmission priority of video streams
- UPnP, DDNS, and IP filtering supported

Specifications

Video

Video Compression: MJPEG or MPEG4 (ISO/IEC 14496-2)

Video Inputs: 4, BNC connector (1.0 Vpp, 75 ohms)

NTSC/PAL: Auto-sensing or manual

Video Resolution and FPS (frames per second):

	NTSC		PAL	
	Size	Max. FPS	Size	Max. FPS
QVGA	320 x 240	30	320 x 288	25
CIF	352 x 240	30	352 x 288	25
VGA	640 x 480	7	640 x 576	7
4CIF	704 x 480	7	704 x 576	7
Full D1	720 x 480	7	720 x 576	7

Video Viewing: Adjustable image size and quality

Audio

Audio Inputs: 1 Line-in or MIC-in with RCA connector

Audio Outputs: 1 Line-out with RCA connector

Network

Protocols: TCP, UDP, HTTP, SMTP, FTP, Telnet, NTP, DNS, DHCP, UPnP, RTP, RTSP, ICMP, IGMPv3, QoS (ToS), SNMPv1/v2c/v3, DDNS, Modbus/TCP

Ethernet: 1 10/100BaseT(X) auto negotiating RJ45 port, or 1 100BaseFX fiber port (single/multi-mode, SC connector)

Optical Fiber:

	100BaseFX	
	Multi-mode	Single-mode
Wavelength	1300 nm	1310 nm
Max. TX	-10 dBm	0 dBm
Min. TX	-20 dBm	-5 dBm
RX Sensitivity	-32 dBm	-34 dBm
Link Budget	12 dB	29 dB
Typical Distance	5 km ^a 4 km ^b	40 km ^c
Saturation	-6 dBm	-3 dBm

- a. 50/125 μm, 800 MHz*km fiber optic cable
- b. 62.5/125 μm, 500 MHz*km fiber optic cable
- c. 9/125 μm single-mode fiber optic cable

Serial Port

PTZ Ports: 1, RS-232/422/485 port (terminal block connector), max. speed of 115.2 Kbps, with 15 KV ESD protection

COM Ports: 1 RS-232/422/485 port (DB9 female connector), max. speed of 115.2 Kbps, with 15 KV ESD protection

Console Port: 1 RS-232 RJ45 port

GPIO

Digital Inputs: 4, max. 8 mA

- High: +13 to +30V
- Low: -30 to +3V

Relay Outputs: 2, max. 24 VDC @ 1 A

LED Indicators

STAT: Indicates if the system booted properly or not

PWR1: Power 1

PWR2: Power 2

FAULT: Can be configured to correspond to system alarm, power failure, video loss, or disconnected network

V1, V2, V3, V4: Video input signal activity

Power Requirements

Input Voltage: 2 12/24 VDC or 24 VAC inputs for redundancy

Power Consumption: Approx. 12 W

Physical Characteristics

Housing: Metal, IP30 protection

Dimensions: 80.2 x 135 x 105 mm (3.16 x 5.31 x 4.13 in)

Weight: 1100 g

Installation: DIN-Rail mounting, wall mounting (with optional kit)

Alarms

Video Motion Detection: Includes sensitivity tuning

Video Loss: Video loss alarm

Scheduling: Daily repeat timing schedule

Imaging: JPEG snapshots for pre/trigger/post alarm images

Email/FTP Messaging: Automatic transfer of stored images via email or FTP with event-triggered actions

Custom Alarms: HTTP event servers for setting customized alarm actions

PAN/TILT/ZOOM

PTZ Camera Control: Via RS-232/422/485 PTZ port or COM port

PTZ Control Functions: PAN, TILT, ZOOM, FOCUS, moving speed, preset position (max. 25 positions), and 10 custom commands

PTZ Function Updates: Driver upload supported

Supported Devices and Protocols: Pelco D, Pelco P, Dynacolor DynaDome, Custom Camera

Transparent PTZ Control: Control PTZ cameras with legacy PTZ control panel or keyboard connected to a PC or VPort decoder

Security

Password: User level password protection

Filtering: By IP address

Environmental Limits

Operating Temperature:

Standard Models: 0 to 60°C (32 to 140°F)

Wide Temp. Models: -40 to 75°C (-40 to 167°F)

Storage Temperature: -40 to 85°C (-40 to 185°F)

Ambient Relative Humidity: 5 to 95% (non-condensing)

Regulatory Approvals

Safety: UL508

EMS:

EN61000-4-2 (ESD), level 2

EN61000-4-3 (RS), level 3

EN61000-4-4 (EFT), level 3

EN61000-4-5 (Surge), level 3

EN61000-4-6 (CS), level 3

EN61000-4-12 (Oscillatory wave immunity), level 3

EMI: FCC Part 15, CISPR (EN55022) class A

Hazardous Location: UL/cUL Class I, Division 2, Groups A, B, C and D (Pending); ATEX Class I, Zone 2, Ex nC IIC (Pending)

Shock: IEC 60068-2-27

Freefall: IEC 60068-2-32

Vibration: IEC 60068-2-6

Note: Please check Moxa's website for the most up-to-date certification status.

MTBF (meantime between failures)

Time: 200,000 hrs

Database: MIL-HDBK-217F, GB 25°C

Warranty

Warranty Period: 5 years

Details: See www.moxa.com/warranty

System Requirements

CPU: Pentium 4, 2.4 GHz or above

Memory: 512 MB memory or above

OS: Windows XP/2000 with SP2 or above

Browser: Internet Explorer 6.x or above

Multimedia: DirectX 9.0c or above

Software Bundled Free

SoftDVR™ Lite: 1 to 4-ch IP surveillance software for viewing and recording

VPort SDK PLUS: Includes CGI commands, ActiveX Control, and API library for customized applications or system integration for third-party developers (the latest version of SDK is available for download from Moxa's website).

Dimensions (unit = mm)

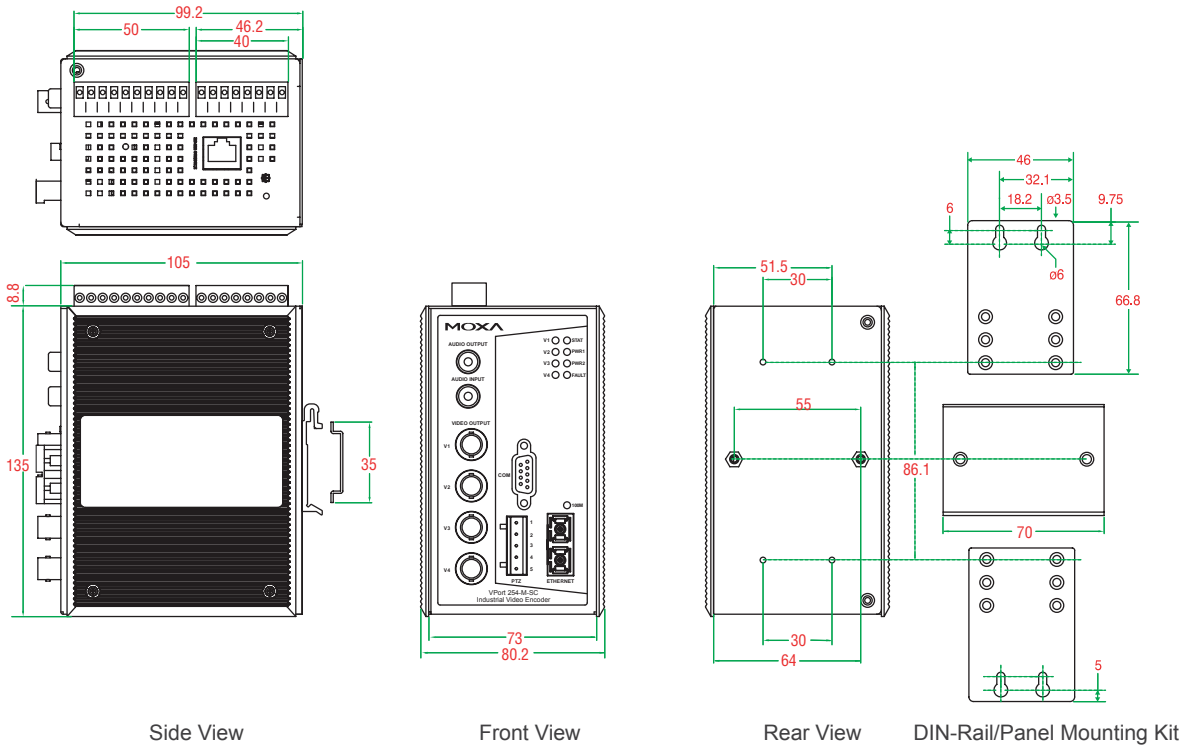

Ordering Information

Available Models		Port Interface		
Standard Temperature (0 to 60 °C)	Wide Temperature (-40 to 75 °C)	10/100BaseT(X)	Multi-mode, SC Connector	Single-mode, SC Connector
VPort 254	VPort 254-T	1	---	---
VPort 254-M-SC	VPort 254-M-SC-T	---	1	---
VPort 254-S-SC	VPort 254-S-SC-T	---	---	1

Optional Accessories (can be purchased separately)

SoftNVR: Expandable IP surveillance software for managing up to 64 video channels

SoftDVR™ Pro: 16-channel IP surveillance software for viewing and recording

DR-4524/75-24/120-24: 45/75/120 W DIN-Rail 24 VDC power supplies

MDR-40-24/60-24: 40/60 W DIN-Rail 24 VDC power supplies, -20 to 70°C operating temperature

WK-46: Wall mounting kit

RK-4U: 4U-high 19" rack mounting kit

VPort 351 Series

Full motion, 1-channel MJPEG/MPEG4 industrial video encoder



- > Industrial design with -40 to 75°C operating temperature and fiber optic Ethernet port
- > Video stream up to 30 frames/sec at full D1 (720 x 480) resolution
- > Pre/post-alarm video recording function for advanced surveillance
- > 2-way (1-in/1-out) audio supported
- > Free VPort SDK PLUS and 4-channel video surveillance software

The certification logos shown here apply to some or all of the products in this section. For details, see "Regulatory Approvals" under "Specifications" below.



Introduction

The VPort 351 is a high performance, 1-channel industrial video encoder that provides up to full D1, full frame rate performance (NTSC: 720 x 480 @ 30 FPS; PAL: 720 x 576 @ 25 FPS) and supports a dual MJPEG/MPEG4 algorithm, making it especially well-suited for use with distributed surveillance systems in critical industrial applications. In

addition, a continuous pre/post event trigger video record function can help system administrators determine why an alarm was triggered, and 2-way audio is provided for the convenience of real-time communication between system administrators located at the central site, and engineers in the field.

Rugged Design for Mission-critical Industrial Environments

- -40 to 75°C wide operating temperature
- Built-in single-mode or multi-mode optical fiber Ethernet port; no media converter required
- UL508 and Class 1, Div. 2 certified for hazardous locations
- Redundant 12/24 VDC and 24 VAC power inputs to ensure greater reliability
- Metal housing with IP30 protection against dust
- DIN-Rail mounting installation for industrial environments

Advanced Network Protocols Support Efficient Network Transmission and Integration

- Standard RTSP (real-time streaming protocol) video streaming for easy integration
- Multicast (IGMP) protocols for efficient network transmission
- SNMPv1/v2c/v3 MIB-II for easy network management
- QoS (ToS) for configuring the transmission priority of video streams
- UPnP, DDNS, and IP filtering supported

Transparent PTZ Control for Easy Control of PTZ Cameras

The VPort 351 adopts Moxa's Real COM technology to implement transparent communication for RS-232/422/485 PTZ control. The benefit of this transparent PTZ control function is that it eliminates

the need to build a PTZ control driver into the VPort product, since legacy PTZ control panels or keyboards can be used to control the PTZ camera directly.

Legacy PTZ Camera Control

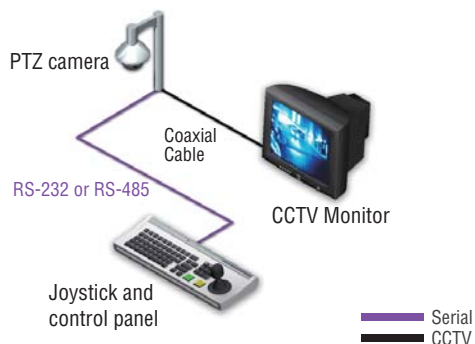

Transparent PTZ Camera Control over Ethernet

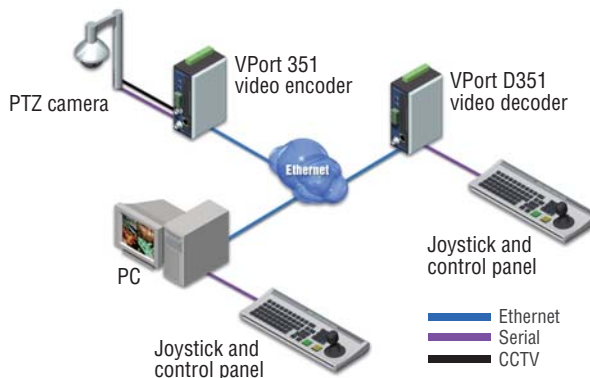

Specifications

Video

Video Compression: MJPEG or MPEG4 (ISO/IEC 14496-2)

Video Inputs: 1, BNC connector (1.0 Vpp, 75 ohms)

Video Outputs: 1, loop-through BNC connector

NTSC/PAL: Auto-sensing or manual

Video Resolution and FPS (frames per second):

	NTSC		PAL	
	Size	Max. FPS	Size	Max. FPS
QVGA	320 x 240	30	320 x 288	25
CIF	352 x 240	30	352 x 288	25
VGA	640 x 480	30	640 x 576	25
4CIF	704 x 480	30	704 x 576	25
Full D1	720 x 480	30	720 x 576	25

Video Viewing:

- Adjustable image size and quality
- Timestamp and text overlay

Audio

Audio Inputs: 1 Line-in or MIC-in with 3.5 mm phone jack

Audio Outputs: 1 Line-out with 3.5 mm phone jack

Network

Protocols: TCP, UDP, HTTP, SMTP, FTP, Telnet, NTP, DNS, DHCP, UPnP, RTP, RTSP, ICMP, IGMPv3, QoS, SNMPv1/v2c/v3, DDNS

Ethernet: 1 10/100BaseT(X) auto negotiating RJ45 port, or 1 100BaseFX fiber port (Single/multi mode, SC connector)

Optical Fiber:

	100BaseFX	
	Multi-mode	Single-mode
Wavelength	1300 nm	1310 nm
Max. TX	-10 dBm	0 dBm
Min. TX	-20 dBm	-5 dBm
RX Sensitivity	-32 dBm	-34 dBm
Link Budget	12 dB	29 dB
Typical Distance	5 km ^a 4 km ^b	40 km ^c
Saturation	-6 dBm	-3 dBm

a. 50/125 μm, 800 MHz*km fiber optic cable

b. 62.5/125 μm, 500 MHz*km fiber optic cable

c. 9/125 μm single-mode fiber optic cable

Serial Port

PTZ Ports: 1, RS-232/422/485 port (terminal block connector), max. speed of 115.2 Kbps

Console Port: 1 RS-232 RJ45 port

GPIO

Digital Inputs: 2, max. 8 mA

- High: +13 to +30V
- Low: -30 to +3V

Relay Outputs: 2, max. 24 VDC @ 1 A

LED Indicators

STAT: Indicates if the system booted properly or not

PWR1: Power 1

PWR2: Power 2

FAULT: Can be configured to correspond to system alarm, power failure, video loss, or disconnected network

VIDEO: Video input signal active

AUDIO TEST: Audio input signal in test mode

PTZ: PTZ control signal active

Power Requirements

Input Voltage: 2 12/24 VDC or 24 VAC inputs for redundancy

Power Consumption: Max. 8 W

Physical Characteristics

Housing: Metal, IP30 protection

Dimensions: 52.98 x 135 x 105 mm (2.09 x 5.31 x 4.13 in)

Weight: 960 g

Installation: DIN-Rail mounting, wall mounting (with optional kit)

Alarms

Pre/Post Alarm: 9 MB memory for video recordings

Video Motion Detection: Includes sensitivity tuning

Video Loss: Video loss alarm

Scheduling: Daily repeat timing schedule

Imaging: JPEG snapshots for pre/trigger/post alarm images

Email/FTP Messaging: Automatic transfer of stored images via email or FTP with event-triggered actions

Custom Alarms: HTTP event servers for setting customized alarm actions

PAN/TILT/ZOOM

PTZ Camera Control: Via RS-232/422/485 PTZ port

PTZ Control Functions: PAN, TILT, ZOOM, FOCUS, moving speed, preset position (max. 25 positions), and 10 custom commands

PTZ Function Updates: Driver upload supported

Supported Device Protocols: Pelco D, Pelco P, Dynacolor DynaDome, Custom Camera

Transparent PTZ Control: Control PTZ cameras with legacy PTZ control panel or keyboard connected to a PC or VPort decoder

Security

Password: User level password protection

Filtering: By IP address

Environmental Limits

Operating Temperature:

Standard Models: 0 to 60°C (32 to 140°F)

Wide Temp. Models: -40 to 75°C (-40 to 167°F)

Storage Temperature: -40 to 85°C (-40 to 185°F)

Ambient Relative Humidity: 5 to 95% (non-condensing)

Regulatory Approvals

Safety: UL508

EMS:

EN61000-4-2 (ESD), level 2

EN61000-4-3 (RS), level 3

EN61000-4-4 (EFT), level 3

EN61000-4-5 (Surge), level 3

EN61000-4-6 (CS), level 3

EN61000-4-12 (Oscillatory wave immunity), level 3

EMI: FCC Part 15, CISPR (EN55022) class A

Hazardous Location: UL/cUL Class I, Division 2, Groups A, B, C and D; ATEX Class I, Zone 2, Ex nC IIC

Shock: IEC 60068-2-27

Freefall: IEC 60068-2-32

Vibration: IEC 60068-2-6

Note: Please check Moxa's website for the most up-to-date certification status.

MTBF (mean time between failures)

Time: 272,000 hrs

Database: MIL-HDBK-217F, GB 25°C

Warranty

Warranty Period: 5 years

Details: See www.moxa.com/warranty

System Requirements

CPU: Pentium 4, 2.4 GHz or above

Memory: 512 MB memory or above

OS: Windows XP/2000 with SP2 or above

Browser: Internet Explorer 6.x or above

Multimedia: DirectX 9.0c or above

Software Bundled Free

SoftDVR™ Lite: 1 to 4-ch IP surveillance software for viewing and recording

VPort SDK PLUS: Includes CGI commands, ActiveX Control, and API library for customized applications or system integration for third-party developers (the latest version of SDK is available for download from Moxa's website).

Dimensions (unit = mm)

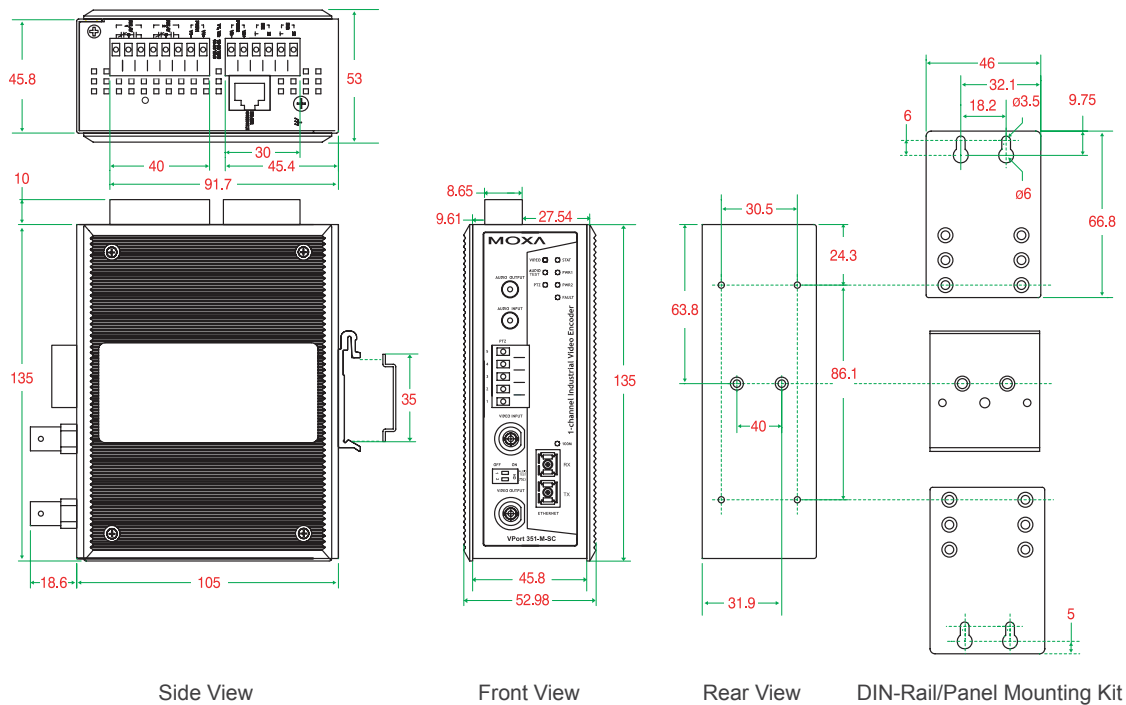

Ordering Information

Available Models		Port Interface		
Standard Temperature (0 to 60 °C)	Wide Temperature (-40 to 75 °C)	10/100BaseT(X)	Multi-mode, SC Connector	Single-mode, SC Connector
VPort 351	VPort 351-T	1	---	---
VPort 351-M-SC	VPort 351-M-SC-T	---	1	---
VPort 351-S-SC	VPort 351-S-SC-T	---	---	1

Optional Accessories (can be purchased separately)

SoftNVR: Expandable IP surveillance software for managing up to 64 video channels

SoftDVR™ Pro: 16-channel IP surveillance software for viewing and recording

DR-4524/75-24/120-24: 45/75/120 W DIN-Rail 24 VDC power supplies

MDR-40-24/60-24: 40/60 W DIN-Rail 24 VDC power supplies, -20 to 70°C operating temperature

WK-46: Wall mounting kit

RK-4U: 4U-high 19" rack mounting kit

VPort 3310 Series

Rugged 1-channel MPEG4 industrial video server (encoder)



- > Industrial design with -40 to 75°C operating temperature
- > Compress analog video/audio signals in MPEG4 video stream
- > Multicast (IGMP) for transmission efficiency
- > Video stream up to 30 frames/sec at CIF (352 x 240) resolution
- > Free VPort SDK and 4-channel video surveillance software

The certification logos shown here apply to some or all of the products in this section. For details, see "Regulatory Approvals" under "Specifications" below.



Introduction

The VPort 3310 is a 1-channel industrial video server (encoder) that uses the standard MPEG4 algorithm, and features DIN-Rail mounting capability, 24 VDC redundant power inputs, and IP30 protection to meet the requirements of industrial environments. A cutting edge MPEG4 algorithm gives the VPort 3310 an FPS of up

to 30 in CIF resolution (352 x 240), with maximum bandwidth of 1.6 Mbps, to provide high video performance and more efficient network transmission. In addition, the VPort 3310 also supports audio communication for a voice-over-IP solution, making the control of your video surveillance system more real-time.

Specifications

Video

- Video Compression:** MPEG4 (ISO/IEC 14496-2)
- Video Inputs:** 1, BNC connector (1.0 Vpp, 75 ohms)
- Video Outputs:** 1, loop-through BNC connector
- NTSC/PAL:** Auto-sensing or manual
- Video Resolution and FPS (frames per second):**

	NTSC		PAL	
	Size	Max. FPS	Size	Max. FPS
QCIF	176 x 120	30	176 x 144	25
CIF	352 x 240	30	352 x 288	25
VGA	640 x 480	10	640 x 576	8
4CIF	704 x 480	10	704 x 576	8

Video Viewing:

- Adjustable image size and quality
- B/W or color control
- Timestamp and text overlay

Audio

Audio Inputs: 1 Line-in or MIC-in with 3.5 mm phone jack

Network

Protocols: TCP, UDP, HTTP, SMTP, FTP, RTSP, RTP, RTCP, NTP, DNS, DDNS, IGMPv3, SNMPv1/v2c/v3, DHCP, UPnP, PPPoE

Ethernet: 1 10/100BaseT(X) auto negotiating RJ45 port

Serial Port

COM Ports: 1, RS-232 (DB9 male connector) or RS-485 (terminal block connector), max. speed of 115.2 Kbps

GPIO

- Digital Inputs:** 2, max. 8 mA
 - High: +13 to +30V
 - Low: -30 to +3V
- Relay Outputs:** 2, max. 24 VDC @ 1 A

LED Indicators

- PWR1:** Power 1
- PWR2:** Power 2
- FAULT:** Power failure
- VIDEO:** Video input
- AUDIO:** Audio input
- SERIAL:** COM port status

Power Requirements

- Input Voltage:** 2 24 VDC power inputs for redundancy
- Power Consumption:** Max. 7.5 W

Physical Characteristics

- Housing:** Metal, IP30 protection
- Dimensions:** 52.98 x 135 x 105 mm (2.09 x 5.31 x 4.13 in)
- Weight:** 790 g
- Installation:** DIN-Rail mounting, wall mounting (with optional kit)

Alarms

- Video Motion Detection:** Includes sensitivity tuning
- Scheduling:** Daily repeat timing schedule
- Imaging:** JPEG snapshots for pre/trigger/post alarm images
- Email/FTP Messaging:** Automatic transfer of stored images via email or FTP with event-triggered actions

PAN/TILT/ZOOM

PTZ Camera Control: Via RS-232/485 port
Supported Device Protocol: Sony VISCA, Cannon VC-C1/VC-C3/VC-C4, Samsung SmartDOME, Dynacolor DynaDOME, Pelco D protocol, Liling PIH-7x00, Ernitec, Custom Camera

Detection: Automatic PTZ camera model detection

Security

Password: User level password protection
Filtering: By IP address

Environmental Limits

Operating Temperature:
 Standard Models: 0 to 60°C (32 to 140°F)
 Wide Temp. Models: -40 to 75°C (-40 to 167°F)
Storage Temperature: -40 to 85°C (-40 to 185°F)
Ambient Relative Humidity: 5 to 95% (non-condensing)

Regulatory Approvals

EMI: FCC Part 15, CISPR (EN55022) class B
EMS:
 EN61000-4-2 (ESD), level 2
 EN61000-4-3 (RS), level 3
 EN61000-4-4 (EFT), level 4
 EN61000-4-5 (Surge), level 3
 EN61000-4-6 (CS), level 3
 EN61000-4-8
 EN61000-4-11
 EN61000-4-12

Shock: IEC 60068-2-27
Freefall: IEC 60068-2-32
Vibration: IEC 60068-2-6

Note: Please check Moxa's website for the most up-to-date certification status.

MTBF (meantime between failures)

Time: 152,000 hrs
Database: MIL-HDBK-217F, GB 25°C

Warranty

Warranty Period: 5 years
Details: See www.moxa.com/warranty

System Requirements

CPU: Pentium 4, 2.4 GHz or above
Memory: 512 MB memory or above
OS: Windows XP/2000 with SP2 or above
Browser: Internet Explorer 6.x or above
Multimedia: DirectX 9.0c or above

Software Bundled Free

SoftDVR™ Lite: 1 to 4-ch IP surveillance software for viewing and recording
VPort SDK: Includes CGI commands, ActiveX Control, and API library for customized applications or system integration for third-party developers (please contact a Moxa sales representative for details).

Dimensions (unit = mm)

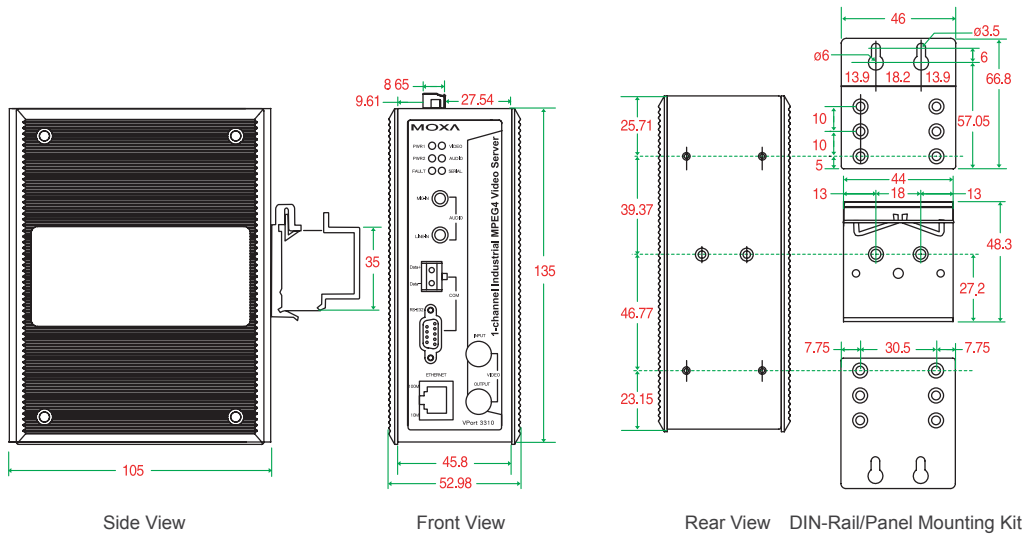

: Ordering Information

Available Models

VPort 3310: 1-channel MPEG4 industrial video server with 24 VDC redundant power inputs, 0 to 60°C operating temperature
VPort 3310-T: 1-channel MPEG4 industrial video server with 24 VDC redundant power inputs, -40 to 75°C operating temperature

Optional Accessories (can be purchased separately)

SoftDVR™ Pro: 16-channel IP surveillance software for viewing and recording
DR-4524/75-24/120-24: 45/75/120 W DIN-Rail 24 VDC power supplies
MDR-40-24/60-24: 40/60 W DIN-Rail 24 VDC power supplies, -20 to 70°C operating temperature
WK-46: Wall mounting kit
RK-4U: 4U-high 19" rack mounting kit

VPort 2141

Compact, 4-channel MJPEG video server (encoder)



- > Compress analog video signals in MJPEG video streams
- > Video stream up to 30 frames/sec at CIF (352 x 240) resolution, and 15 frames/sec at Quad view
- > PPPoE, DDNS, UPnP, and IP filtering supported
- > Free VPort SDK and 4-channel video surveillance software

The certification logos shown here apply to some or all of the products in this section. For details, see "Regulatory Approvals" under "Specifications" below.



Introduction

The VPort 2141 video server comes equipped with a 4-channel video input image digitizer, image compressor with MJPEG compression, and web server accessible through a 10/100 Mbps Ethernet port. With

the VPort 2141, you can digitize analog video sources and distribute digital images over an IP network to turn your CCTV system into a true "Video-over-IP" network system.

Specifications

Video

Video Compression: MJPEG

Video Inputs: 4, BNC connector (1.0 Vpp, 75 ohms)

NTSC/PAL: Auto-sensing or manual

Video Resolution and FPS (frames per second):

	NTSC		PAL	
	Size	Max. FPS	Size	Max. FPS
QCIF	176 x 120	30	176 x 144	25
CIF	352 x 240	30	352 x 288	25
4CIF	704 x 480	10	704 x 576	8
Quad		15		15

Video Viewing:

- Adjustable image size and quality
- B/W or color control
- Timestamp and text overlay
- 5 privacy masks for each camera

Network

Protocols: TCP, HTTP, SMTP, FTP, NTP, DNS, DHCP, PPPoE, DDNS, UPnP

Ethernet: 1 10/100BaseT(X) auto negotiating RJ45 port

Serial Port

COM1 Port: RS-232 (DB9 male connector), max. speed of 115.2 Kbps

COM2 Port: RS-485 (terminal block connector), max. speed of 115.2 Kbps

GPIO

Digital Inputs: 4, max. 12 VDC @ 50 mA

Relay Outputs: 4, max. 24 VDC @ 1 A, 125 VAC @ 0.5 A

LED Indicators

Network: ACTIVE, LINK, FDX (full duplex)

System: POWER, CONNECT, SERIAL

Power Requirements

Input Voltage: 12 VDC, 1.5 A

Power Consumption: Approx. 8 W

Alternative Power Input: Terminal block for 12 to 15 VDC/VAC, min. 1.5A

Power Output: Terminal block for 12 VDC, max. 500 mA

Physical Characteristics

Housing: Metal

Dimensions: 146.2 x 163.2 x 40 mm (5.76 x 6.43 x 1.57 in)

Weight: 820 g

Installation: DIN-Rail mounting (with optional kit), wall mounting

Alarms

Video Motion Detection: Includes sensitivity tuning

Scheduling: Daily repeat timing schedule

Imaging: JPEG snapshots for pre/trigger/post alarm images

Email/FTP Messaging: Automatic transfer of stored images via email or FTP with event-triggered actions

PAN/TILT/ZOOM

PTZ Camera Control: Via RS-232/485 port

Supported Device Protocol: Sony VISCA, Cannon VC-C1/VC-C3/VC-C4, Samsung SmartDOME, Dynacolor DynaDOME, Pelco D protocol, Liling PIH-7x00, Ernitec, Custom Camera

Detection: Automatic PTZ camera model detection

Security

Password: User level password protection

Filtering: By IP address

Environmental Limits

Operating Temperature: 0 to 60°C (32 to 140°F)
Storage Temperature: -40 to 70°C (-40 to 158°F)
Ambient Relative Humidity: 5 to 95% (non-condensing)

Regulatory Approvals

Safety: CE
EMI: FCC
Note: Please check Moxa's website for the most up-to-date certification status.

Warranty

Warranty Period: 5 years
Details: See www.moxa.com/warranty

System Requirements

CPU: Pentium 4, 2.4 GHz or above
Memory: 512 MB memory or above
OS: Windows XP/2000 with SP2 or above

Browser: Internet Explorer 6.x or above
Multimedia: DirectX 9.0c or above

Software Bundled Free

SoftDVR™ Lite: 1 to 4-ch IP surveillance software for viewing and recording
VPort SDK: Includes CGI commands, ActiveX Control, and API library for customized applications or system integration for third-party developers (please contact a Moxa sales representative for details).

Dimensions (unit = mm)

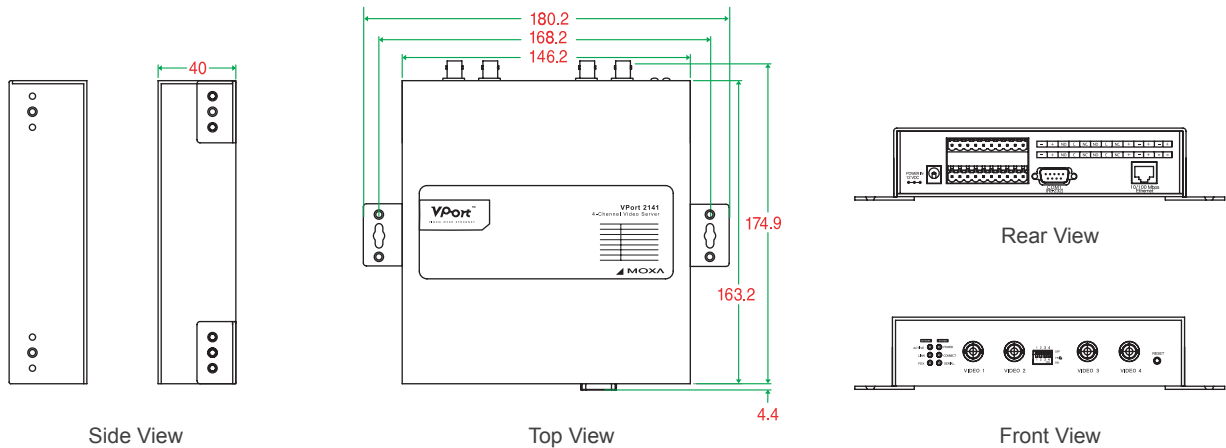

Ordering Information

Available Models

VPort 2141: 4-channel MJPEG video server with 100-240 V power adaptor (12 VDC, 1.5A, or 12 VDC, 1.25A for UK plug)

Optional Accessories (can be purchased separately)

SoftDVR™ Pro: 16-channel IP surveillance software for viewing and recording
DK-35A: DIN-Rail mounting kit (35 mm)

VPort 251

Full motion, 1-channel MJPEG/MPEG4 video encoder



- > Compress analog video/audio signals into MJPEG/MPEG4 video streams
- > Video stream up to 30 frames/sec at full D1 (720 x 480) resolution
- > 2-way (1-in/1-out) audio supported
- > Transparent PTZ control for using legacy PTZ control panel or keyboard
- > Loop-through power output for powering an analog camera
- > Free VPort SDK PLUS and 4-channel video surveillance software

The certification logos shown here apply to some or all of the products in this section. For details, see "Regulatory Approvals" under "Specifications" below.



Introduction

The VPort 251 is a high performance, 1-channel video encoder with compact form factor that is suitable for installation in a variety of locations, including outdoor camera cabinets. To make installation easier, the VPort 251 supports both panel mounting and DIN-Rail mounting (with DK-35A accessory), and 1 loop-through power output for powering an analog camera. In addition, the VPort 251 provides

up to full D1, full frame rate video performance (NTSC: 720 x 480 up to 30 FPS; PAL: 720 x 576 up to 25 FPS) and supports both MJPEG or MPEG4, making it especially well-suited for use with distributed video surveillance systems, and a 2-way audio function is provided for the convenience of real-time communication between system administrators located at the central site, and engineers in the field.

Specifications

Video

Video Compression: MJPEG or MPEG4 (ISO/IEC 14496-2)

Video Inputs: 1, BNC connector (1.0 Vpp, 75 ohms)

Video Outputs: Via Ethernet port (1.0 Vpp, 75 ohms)

NTSC/PAL: Auto-sensing or manual

Video Resolution and FPS (frames per second):

	NTSC		PAL	
	Size	Max. FPS	Size	Max. FPS
QVGA	320 x 240	30	320 x 288	25
CIF	352 x 240	30	352 x 288	25
VGA	640 x 480	30	640 x 576	25
4CIF	704 x 480	30	704 x 576	25
Full D1	720 x 480	30	720 x 576	25

Video Viewing:

- Adjustable image size and quality
- Timestamp and text overlay

Audio

Audio Inputs: 1 Line-in or MIC-in with 3.5 mm phone jack

Audio Outputs: 1 Line-out with 3.5 mm phone jack

Network

Protocols: TCP, UDP, HTTP, SMTP, FTP, Telnet, NTP, DNS, DHCP, UPnP, RTP, RTSP, ICMP, IGMPv3, QoS, DDNS, SNMPv1/v2c/v3

Ethernet: 1 10/100BaseT(X) auto negotiating RJ45 port

Serial Port

PTZ Ports: 1, RS-232/422/485 (terminal block connector), max. 115.2 Kbps

Console Port: 1 RS-232 RJ45 port

GPIO

Digital Inputs: 1, max. 8 mA

- High: +13 to +30V
- Low: -30 to +3V

Relay Outputs: 1, max. 24 VDC @ 1 A

LED Indicators

STAT: Indicates if the system booted properly or not

VIDEO: Video input signal active

PTZ: PTZ control signal active

Power Requirements

Input Voltage: 12/24 VDC or 24 VAC input

Power Consumption: Approx. 7.5 W

Power Output: 2-pin terminal block connector for loop-through from power input

Physical Characteristics

Housing: Metal

Dimensions: 88.2 x 106 x 50 mm (3.47 x 4.17 x 1.97 in)

Weight: 850 g

Installation: DIN-Rail mounting (with optional kit), wall mounting

Alarms

Video Motion Detection: Includes sensitivity tuning

Video Loss: Video loss alarm

Scheduling: Daily repeat timing schedule

Imaging: JPEG snapshots for pre/trigger/post alarm images

Email/FTP Messaging: Automatic transfer of stored images via email or FTP with event-triggered actions

Custom Alarms: HTTP event servers for setting customized alarm actions

PAN/TILT/ZOOM

PTZ Camera Control: Via RS-232/422/485 PTZ port

PTZ Control Functions: PAN, TILT, ZOOM, FOCUS, moving speed, preset position (max. 25 positions), and 10 custom commands

PTZ Function Updates: Driver upload supported

Supported Device Protocols: Pelco D, Pelco P, Dynacolor DynaDome, Custom Camera

Transparent PTZ Control: Control PTZ cameras with legacy PTZ control panel or keyboard connected to a PC or VPort decoder

Security

Password: User level password protection

Filtering: By IP address

Environmental Limits

Operating Temperature: 0 to 60°C (32 to 140°F)

Storage Temperature: -40 to 85°C (-40 to 185°F)

Ambient Relative Humidity: 5 to 95% (non-condensing)

Regulatory Approvals

EMS:

EN61000-4-2 (ESD), level 2

EN61000-4-3 (RS), level 3

EN61000-4-4 (EFT), level 3

EN61000-4-5 (Surge), level 3

EN61000-4-6 (CS), level 3

EN61000-4-12 (Oscillatory wave immunity), level 3

EMI: FCC Part 15, CISPR (EN55022) class A

Shock: IEC 60068-2-27

Freefall: IEC 60068-2-32

Vibration: IEC 60068-2-6

Note: Please check Moxa's website for the most up-to-date certification status.

MTBF (meantime between failures)

Time: 280,000 hrs

Database: MIL-HDBK-217F, GB 25°C

Warranty

Warranty Period: 5 years

Details: See www.moxa.com/warranty

System Requirements

CPU: Pentium 4, 2.4 GHz or above

Memory: 512 MB memory or above

OS: Windows XP/2000 with SP2 or above

Browser: Internet Explorer 6.x or above

Multimedia: DirectX 9.0c or above

Software Bundled Free

SoftDVR™ Lite: 1 to 4-ch IP surveillance software for viewing and recording

VPort SDK PLUS: Includes CGI commands, ActiveX Control, and API library for customized applications or system integration for third-party developers (the latest version of SDK is available for download from Moxa's website).

Dimensions (unit = mm)

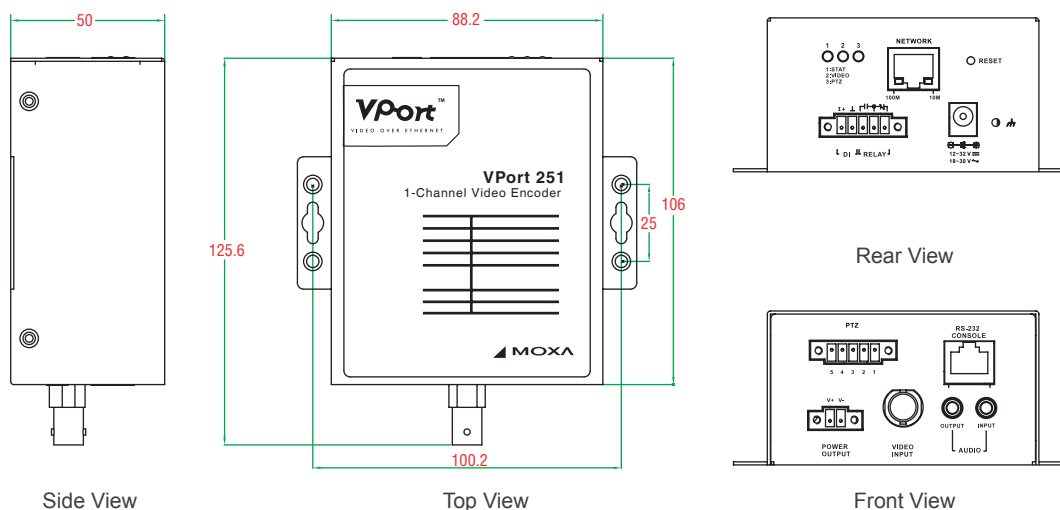

Ordering Information

Available Models

VPort 251: 1-channel MJPEG/MPEG4 video encoder, 0 to 60°C operating temperature

Optional Accessories (can be purchased separately)

SoftNVR: Expandable IP surveillance software for managing up to 64 video channels

SoftDVR™ Pro: 16-channel IP surveillance software for viewing and recording

Power Adaptors:

- PWR-12120-USJP-S2: L-type (5.5/2.1/9.5) power adaptor, 1.2 A @ 12 VDC output, US/JP plug
- PWR-12120-DT-S2: S-type (5.5/2.1/7.5) power adaptor, 1.2 A @ 12 VDC output
- PWR-12200-DT-S1: S-type (5.5/2.1/7.5) power adaptor, 2 A @ 12 VDC output
- PWR-12120-AU-S2: L-type (5.5/2.1/9.0) power adaptor, 1.2 A @ 12 VDC output, AU plug
- PWR-12150-EU-S2: L-type (5.5/2.1/9.0) power adaptor, 1.5 A @ 12 VDC output, Euro plug
- PWR-12150-UK-S2: L-type (5.5/2.1/9.0) power adaptor, 1.5 A @ 12 VDC output, UK plug

DK-35A: DIN-Rail mounting kit (35 mm)

VPort D351

1-channel MJPEG/MPEG4 industrial video decoder



- > Decode MJPEG and MPEG4 video streams to an analog video signal automatically
- > Manual selection or automatic scan with maximum of 64 video sources
- > 2-way (1-in/1-out) audio supported
- > Transparent PTZ control with legacy PTZ controller
- > SNMP for network management

The certification logos shown here apply to some or all of the products in this section. For details, see "Regulatory Approvals" under "Specifications" below.



Introduction

The VPort D351 is a 1-channel video decoder for decoding MPEG4/MJPEG video streams from VPort series video encoders (not including VPort 2110, VPort 2140, VPort 2310, VPort 2141, and VPort 3310) and VPort IP cameras back to analog video signals. The analog video signal can be sent to legacy CCTV devices, such as monitors, multiplexers, and matrix switches, which can be used as originally intended as part of CCTV systems. In addition, bi-directional audio enables ready-to-use voice-over-IP communication between the

video encoder and decoder. Monitoring your cameras that are part of a large CCTV system is easy with the VPort D351, which can be set up to switch between different video sources either manually or automatically within a given time interval. Up to 64 video sources can be included in the list. In addition, the 2 DIs located on the top panel of the VPort D351 can be used to create 2 control buttons for up and down video source selection.

Specifications

Video

Video Decoding: MPEG4, MJPEG (auto-detecting)

Video Inputs: Accepts video streams from VPort series video encoders and VPort series IP cameras over TCP/IP networks (not included: VPort 2110, VPort 2140, VPort 2310, VPort 2141, VPort 3310)

Video Outputs: 1, BNC connector (1.0 Vpp, 75 ohms), NTSC or PAL

Video Resolution: Max. of 540 TVL lines

Video Sources: Up to 64, selected manually by web server or digital inputs, or selected automatically by scanning within a set time interval

Video Viewing:

- Max. 30/25 FPS (NTSC/PAL) can be decoded
- OSD (on-screen display) with video source, video source IP, date/time, and customized information

Audio

Audio Inputs: 1 Line-in or Mic-in with 3.5 mm phone jack

Audio Outputs: 1 Line-out with 3.5 mm phone jack

Network

Protocols: TCP, UDP, HTTP, SMTP, Telnet, NTP, DNS, DHCP, UPnP, RTP, RTSP, SNMPv1/v2c/v3

Ethernet: 1 10/100BaseT(X) auto negotiating RJ45 port

Serial Port

PTZ Ports: 1, RS-232/422/485 (terminal block connector), max. 115.2 Kbps

Console Port: 1 RS-232 RJ45 port

GPIO

Digital Inputs: 2, max. 8 mA

- High: +13 to +30V
- Low: -30 to +3V

Relay Outputs: 2, max. 24 VDC @ 1 A

LED Indicators

STAT: Indicates if the system booted properly or not

PWR1: Power 1

PWR2: Power 2

FAULT: Can be configured to correspond to system alarm, power failure, video loss, or disconnected network

Power Requirements

Input Voltage: 2 12/24 VDC or 24 VAC inputs for redundancy

Power Consumption: Max. 7.5 W

Physical Characteristics

Housing: Metal, IP30 protection

Dimensions: 52.98 x 135 x 105 mm (2.09 x 5.31 x 4.13 in)

Weight: 910 g

Installation: DIN-Rail mounting, wall mounting (with optional kit)

PAN/TILT/ZOOM

PTZ Camera Control: Transparent PTZ camera control with legacy PTZ controller through the RS-232/422/485 PTZ port

Security

Password: User level password protection

Filtering: By IP address

Environmental Limits

Operating Temperature: 0 to 60°C (32 to 140°F)

Storage Temperature: -40 to 85°C (-40 to 185°F)

Ambient Relative Humidity: 5 to 95% (non-condensing)

Regulatory Approvals

Safety: UL508

EMS:

EN61000-4-2 (ESD), level 2

EN61000-4-3 (RS), level 3

EN61000-4-4 (EFT), level 3

EN61000-4-5 (Surge), level 3

EN61000-4-6 (CS), level 2

EN61000-4-12 (Oscillatory wave immunity), level 3

EMI: FCC Part 15, CISPR (EN55022) class A

Shock: IEC 60068-2-27

Freefall: IEC 60068-2-32

Vibration: IEC 60068-2-6

Note: Please check Moxa's website for the most up-to-date certification status.

MTBF (mean time between failures)

Time: 275,000 hrs

Database: MIL-HDBK-217F, GB 25°C

Warranty

Warranty Period: 5 years

Details: See www.moxa.com/warranty

Dimensions (unit = mm)

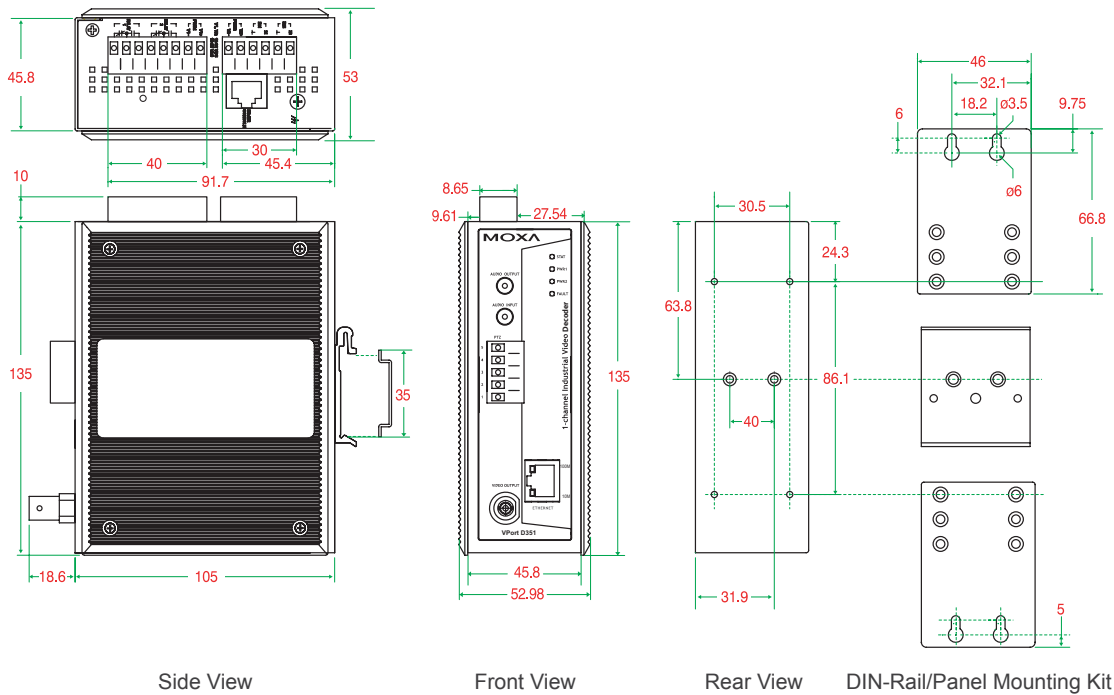

Ordering Information

Available Models

VPort D351: 1-channel MJPEG/MPEG4 industrial video decoder, 0 to 60°C operating temperature

Optional Accessories (can be purchased separately)

DR-4524/75-24/120-24: 45/75/120 W DIN-Rail 24 VDC power supplies

WK-46: Wall mounting kit

RK-4U: 4U-high 19" rack mounting kit

VPort 25 Series

IP66, day-and-night vandal-proof fixed dome IP camera for outdoors



- > -40 to 50°C operating temperature; heater or fan not required
- > IP66-rated for protection from rain and dust
- > Direct-wired power input and PoE for power redundancy
- > Up to 30 frames/sec at 720 x 480 resolution
- > One camera lens for both day and night use

The certification logos shown here apply to some or all of the products in this section. For details, see "Regulatory Approvals" under "Specifications" below.



6

Video Networking Solutions > VPort 25 Series

Introduction

The VPort 25 is a vandal-proof, IP66-rated, fixed dome IP camera for use in harsh, outdoor environments. With maximum resolution of 520 TVL and day-and-night CCD camera lens, the VPort 25 is especially well-suited for high performance video surveillance applications. To meet the outdoor environment requirements, the VPort 25 is IP66-

rated to protect it against dust and rain. In addition, the vandal-proof form factor design prevents damage from unexpected external forces, and the case-open sensor sends an alarm message when the VPort 25's outer case is opened.

Heater and fan not required, supports direct-wired power input and PoE for power redundancy

The VPort 25's no-heater/fan-less embedded system provides greater reliability for outdoor use. In addition, the camera comes with

redundant power inputs: (1) direct power connection (12/24 VDC and 24 VAC), and (2) PoE (IEEE 802.3af) power input.

High performance video, with full motion MJPEG/MPEG4 video stream

The VPort 25 uses the ASIC compression chip, which provides video performance up to full D1 (720 x 480) @ 30 FPS. To meet a wider

range of customer requirements, the VPort 25 supports dual-codecs, including the MJPEG and MPEG4 algorithms.

Specifications

Camera

Sensor: 1/3" Sony Super HAD or 1/3" Sony ExView

Lens:

Wide-end: F1.4, diagonal 115.4°, horizontal 90.3°

Tele-end: F2.4, diagonal 39.8°, horizontal 31.9°

Focal Length: F= 3.7-12 mm

Modulation: NTSC or PAL

Camera Angle: Pan: ±180°; tilt: ±85°, rotation: ±170° (camera angles controlled manually)

Illumination:

Color: 0.2 Lux at F1.2

Black and white: 0.03 Lux at F1.2

Synchronization: Internal

Gamma Correction: 0.45

White Balance: Auto tracking white balance

Electronic Shutter Speed: 1/60 (50) second to 1/100,000 second, automatic

S/N Ratio: More than 50 dB (AGC off)

AGC Control: On/Off

Flickerless Control: On/Off

Backlight Compensation: On/Off

Mirror: On/Off

Auto Exposure, Auto Iris:

On: Auto exposure

Off: Auto iris

Horizontal Resolution: 420/520 TVL

Effective Pixels:

NTSC: 510 x 492 (middle resolution), 768 x 494 (high resolution)

PAL: 500 x 582 (middle resolution), 752 x 582 (high resolution)

Video

Video Compression: MJPEG or MPEG4 (ISO/IEC 14496-2)

Video Resolution:

	NTSC		PAL	
	Size	Max. FPS	Size	Max. FPS
QVGA	320 x 240	30	320 x 288	25
CIF	352 x 240	30	352 x 288	25
VGA	640 x 480	30	640 x 576	25
4CIF	704 x 480	30	704 x 576	25
Full D1	720 x 480	30	720 x 576	25

Video Viewing:

- Adjustable image size and quality
- Timestamp and text overlay

Video Output: Via Ethernet port or BNC connector (1.0 Vpp, 75 ohms)

Audio

Audio Input: 1 Line-in or MIC-in with 2-pin terminal block connector

Audio Output: 1 Line-out with 2-pin terminal block connector

Network

Protocols: TCP, UDP, HTTP, SMTP, FTP, Telnet, NTP, DNS, DHCP, UPnP, RTP, RTSP, ICMP, IGMPv3, QoS, SNMPv1/v2c/v3, DDNS
Ethernet: 1 10/100BaseT(X) auto negotiating RJ45 port

GPIO

Digital Inputs: 1, max. 8 mA
 • High: +13 to +30V
 • Low: -30 to +3V

Relay Output: 1, max. 24 VDC @ 1A

LED Indicators

STAT: Indicates if the system booted properly
Network: 1 LED for 10 Mbps, 1 LED for 100 Mbps
System: Power On/Off

DIP Switch: To turn the LED light On/Off

Power Requirements

Input Voltage: Redundant power inputs
 • 12/24 VDC or 24 VAC with 2-pin terminal block connector
 • Power-over-Ethernet (IEEE 802.3af)

Physical Characteristics

Housing: IP66-rated for rain and dust protection, vandal-proof supports
Dimensions: 142 x 118.9 mm (5.60 x 4.68 in)
Weight: 1100 g
Installation: Surface mounting, wall mounting

Alarms

Video Motion Detection: Includes sensitivity tuning
Video Loss: Video loss alarm
Case-open Sensor: Built in case-open sensor alarm
Scheduling: Daily repeat timing schedule
Imaging: JPEG snapshots for pre/trigger/post alarm images
Custom Alarms: HTTP event servers for setting customized alarm actions

Security

Password: User level password protection
Filtering: By IP address

Environmental Limits

Operating Temperature: -40 to 50°C (-40 to 122°F)
Storage Temperature: -40 to 85°C (-40 to 185°F)
Ambient Relative Humidity: 5 to 95% (non-condensing)

Regulatory Approvals

Safety: UL508 (Pending)
EMS:
 EN61000-4-2 (ESD), level 2
 EN61000-4-3 (RS), level 3
 EN61000-4-4 (EFT), level 3
 EN61000-4-5 (Surge), level 3
 EN61000-4-6 (CS), level 3
 EN61000-4-12 (Oscillatory wave immunity), level 3
EMI: FCC Part 15, CISPR (EN55022) class A

Shock: IEC 60068-2-27
Freefall: IEC 60068-2-32
Vibration: IEC 60068-2-6

Note: Please check Moxa's website for the most up-to-date certification status.

Warranty

Warranty Period: 1 year
Details: See www.moxa.com/warranty

System Requirements

CPU: Pentium 4, 2.4 GHz or above
Memory: 512 MB memory or above
OS: Windows XP/2000 with SP2 or above
Browser: Internet Explorer 6.x or above
Multimedia: DirectX 9.0c or above

Software Bundled Free

SoftDVR™ Lite: 1 to 4-ch IP surveillance software for viewing and recording
VPort SDK PLUS: Includes CGI commands, ActiveX Control, and API library for customized applications or system integration for third-party developers (the latest version of SDK is available for download from Moxa's website).

Dimensions (unit = mm)

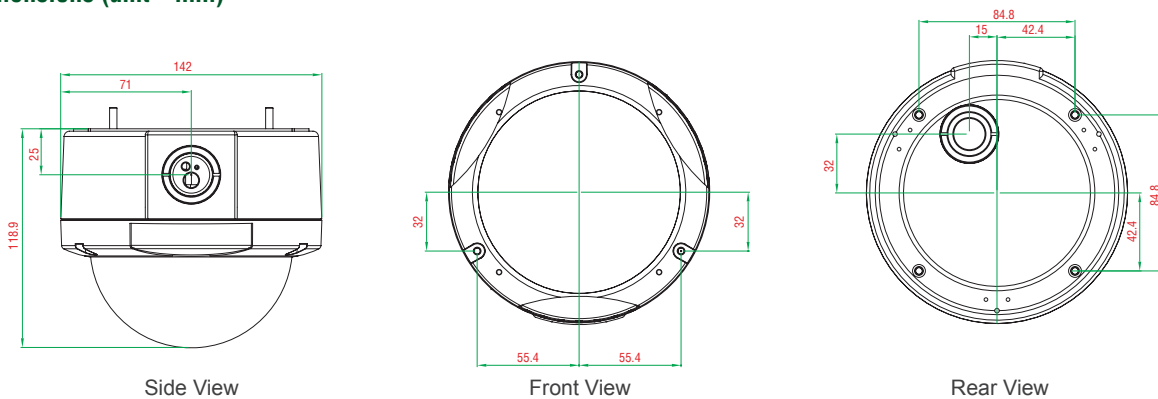

Ordering Information

Available Models	Camera Sensor		Modulation	
	SuperHAD	Exview	NTSC	PAL
VPort 25-CAM3S52N	√	---	√	---
VPort 25-CAM3S52P	√	---	---	√
VPort 25-CAM3E52N	---	√	√	---
VPort 25-CAM3E52P	---	√	---	√

IP Camera Mounting Accessories



Mounting Kit

For mounting dome camera onto straight tube, gooseneck tube, or mini pendant

VP-MK

Height: 71 mm (2.8 in)
Diameter: 132.4 mm (5.21 in)
Weight: 300 g (0.7 lbs)

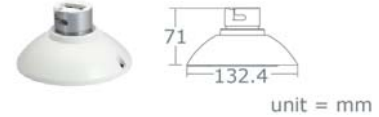

Straight Tube

VP-ST1 or VP-ST2

Height: 250 mm (9.84 in) or 500 mm (19.69 in)
Diameter: 50 mm (1.97 in)
Weight: 1000 g (2.2 lbs)/1800 g (4 lbs)

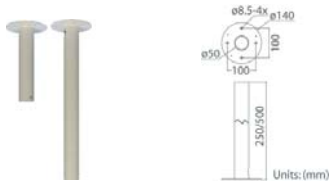

Gooseneck Tube

VP-GT

Dimensions: 323 x 385 mm (11.73 x 15.16 in)
Diameter: 92 x 42 mm (3.62 x 1.65 in)
Weight: 2100 g (4.6 lbs)



Mini Pendant

VP-MP

Dimensions: 184 x 104 x 115.2 mm (7.24 x 4.09 x 4.54 in)
Diameter: 44.5 mm (1.75 in)
Weight: 600 g (1.3 lbs)

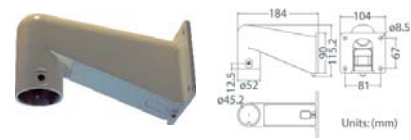

Wall Box Mounting

For mounting gooseneck and mini pendants on a wall

VP-WBM

Dimensions: 270 x 166 x 95 mm (10.63 x 6.54 x 3.74 in)
Weight: 2200 g (4.8 lbs)



Standard Corner Mounting Plate

For mounting gooseneck and mini pendants in a corner

VP-CST

Dimensions: 222 x 204 x 117 mm (8.74 x 8.03 x 4.61 in)
Weight: 2000 g (4.4 lbs)

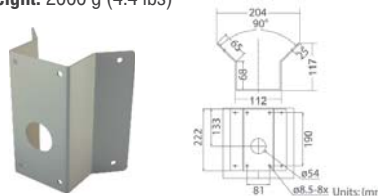

Mini Corner Plate

For mounting gooseneck and mini pendants in a corner

VP-CSTM

Dimensions: 270 x 166 x 95 mm (10.63 x 6.54 x 3.74 in)
Weight: 800 g (1.8 lbs)



Outdoor Thin Pole Direct Mounting

For mounting gooseneck and mini pendants on a pole

VP-PTD

Dimensions: 232 x 136 x 50 mm (9.13 x 5.35 x 1.97 in)
Recommended Pole Diameter: 112 to 140 mm (4.4 to 5.5 in)
Weight: 700 g (1.6 lbs)

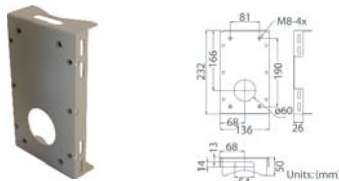

Outdoor Wide Pole Direct Mounting

For mounting gooseneck and mini pendants on a pole

VP-PWD

Dimensions: 270 x 170 x 60 mm (10.63 x 6.69 x 2.36 in)
Recommended Pole Diameter: 112 to 130 mm (4.4 to 5 in)
Weight: 1000 g (2.2 lbs)

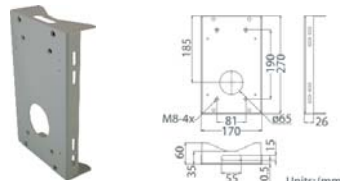

Stainless Steel Straps

For direct pole mounting or mounting a pole box on a pole

VP-SS1

Length: 700 mm (27.56 in)
Width: 16 mm (0.63 in)
Weight: 20 g (0.04 lbs)
Note: Four straps are shipped with each order



SoftNVR

Expandable IP surveillance software for managing up to 64 video channels



Moxa's SoftNVR IP surveillance software can be used to record video over the network and manage up to 64 video stream channels generated by VPort series products (not including the VPort 2000 series and VPort 3310) simultaneously. Features include dual monitor display, video analysis, instant alarm, event recording, and video enhancement tools. SoftNVR gives users an advanced video management tool for medium to large video surveillance networking systems.

Features

- Up to 64 channels in one system
- Dual monitor display capability for convenient viewing
- Video analysis with moving objects, and video loss detection



- Instant response for alarm notification
- Simple and user-friendly setup for recording schedules
- Multifunction playback system with intelligent search

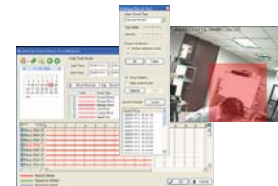

- Video enhancement tools for image quality tuning
- I/O device integration
- Live viewing from popular web browsers



Introduction

Live Display

- Display a maximum of 64 channels, which could be configured for different modes, and in full screen.
- Dual monitor support:
 - Focus on important areas: Users can set one screen to monitor general cameras and the other to monitor important cameras.
 - Live view and playback at the same time: Users can set one screen to watch a live view, and use the other to play back images.
- A "Detected Event" for the spot monitor application can pop up in the secondary monitor while the primary one is viewing live video.
- Adjustable monitor windows: Supports 1, 4, 6, 9, 10, 13, 16, 25, 36, 49, or 64 divided windows in full screen and when using the "display in turns" function.
- Multiple views: Show images from one video source on multiple screens.

PTZ control

- PTZ preset point: Save the definition of PTZ camera lens as a preset point and allow camera to move quickly to that location.
- Patrol: Allow camera to patrol an area based on a combined set of preset points.
- Digital PTZ:
 - Focus on any location you would like to highlight.
 - “Digital PTZ” and “Multiple Show” allow you to put the focus from single video resource anywhere you want.

Smart Detection

- Smart detection of 9 different events
 - General Motion
 - Lose Focus
 - Signal Digital Input
 - System alarm at System Health Unusual
 - Missing Object
 - Camera Occlusion
 - System alarm at Disk Space Exhausted
 - Foreign Object
 - Signal Lost
- Instant response for event alarms
 - On Screen Display
 - PTZ Preset Go
 - Play Sound
 - Signal Digital Output
 - Send E-mail

Recording and Schedule

- Video compression with MPEG4 and MJPEG.
- Record synchronized audio and video.
- Auto recycling when storage disk is full.
- Recording modes: Continuous record, record by event, record by digital input, record by motion, record by schedule, and manual recording.
- Recording schedule: Record daily, weekly, or by repeat schedule.
- Videos and images can be saved in outer storage devices such as DAS, NAS, or SAN without any limitations; useful if you need to increase your storage space in the future.

Remote Access

- Remote Live View by client program and web browser.
- Remote Playback by client program and web browser.
- Remote control PTZ camera.

Playback & Search

- Play back a maximum of 16 channels under different modes and in full screen.
- Intelligent search and smart search modes by event, area, camera, date, time, or log file.
- Administrator can configure the path to the recording database, without limitation. Unlimited support for additional storage devices.
- A search for a recorded video is based on the time period and event, which is the easiest and most efficient way to find the target recorded video.
- Complete playback control: Playback, reverse playback, fast forward.
- Digital zoom in to a specific area.
- Export video to AVI or ASF files.
- Export a single frame to a BMP or JPEG file and print it out.
- Back up the video by burning it to a disc and onto the hard disk.
- Video enhancement: Visibility, sharpness, brightness, contract, grayscale.

System

- User-friendly control interface; no complicated control window, making it easy for anyone with basic computer knowledge to use.
- Administrator can auto login from a certain account, and enable, add, edit, and delete users without limitation. Configure access rights for users.
- Only the users in the administrator group can exit the Main Console.
- Can monitor connection conditions, such as Account, log in time, flow rate, and IP address. Includes remote control information for analyzing data and sorting out responsibilities.
- Log data: Unusual event, system log, counting application can export to “xls” or “txt” file.
- Execute recording, smart guard, and other functions in the background after logging out of the system.
- Supports 22 languages: English, Traditional Chinese, Simplified Chinese, Japanese, French, Spanish, German, Italian, Turkish, Danish, Hungarian, Greece, Finnish, Russian, Thai, Czech, Slovak, Korean, Portuguese, Portuguese (Brazil), Hebrew, Persian

: System Requirements

Total FPS at CIF	600 or more	480 to 600	240 to 480	120 to 240	less than 120
CPU	Intel Core 2 Duo QX6700	Intel Core 2 Duo E6400	Intel Pentium D 930	Intel P4 2.8 GHz	Intel P4 2.4 GHz
RAM	2 GB	1 GB	1 GB	512 MB	512 MB
Motherboard	Intel 945 or 965 chip, Intel chipset recommended				
Display	ATI Radeon 9200, nVIDIA GeForce FX-5200, Intel 945 / 965, or above (ATI recommended)				
Ethernet	100BaseT(X) or above, Gigabit LAN recommended				
Hard Disk	80 GB or above				
OS	MS Windows 2000/XP Pro SP2/2003				

: Ordering Information

Available Models

- SoftNVR-4:** SoftNVR with 4-channel license Key Pro
- SoftNVR-8:** SoftNVR with 8-channel license Key Pro
- SoftNVR-16:** SoftNVR with 16-channel license Key Pro
- SoftNVR-25:** SoftNVR with 25-channel license Key Pro
- SoftNVR-32:** SoftNVR with 32-channel license Key Pro
- SoftNVR-64:** SoftNVR with 64-channel license Key Pro

Package Checklist

- SoftNVR CD:** Includes the SoftNVR software and related documents
- Key Pro:** Plugs into the USB port
- Printed Manual:** Moxa SoftNVR Quick Installation Guide

SoftDVR™ Pro

Easy-to-use 16-channel IP surveillance software



Moxa's SoftDVR™ Pro IP surveillance software is designed for video-over-IP surveillance systems that use Moxa's VPort series of video servers as their distributed video networking solution. With the help of Moxa SoftDVR™, system integrators can seamlessly integrate other applications, such as I/O sensors and alarms, with CCTV systems over an IP-based network.

Introduction

Viewing and Playback—Anywhere, Anytime

- Remote access from popular web browsers
- Supports 1, 4, 6, 8, 9, 10, 13, 16 camera viewing formats
- Maximum of 16 cameras in a system
- Synchronized video/audio viewing and recording (for VPort MPEG4 video servers)
- Historical playback by time and event
- Zoom-in/Zoom-out function for individual cameras when playing back images
- Take snapshots in playback mode to get JPEG images for printing or to save as evidence
- Can adjust the contrast, brightness, sharpness, blur, and grayscale of the snapshot image



Record and Store over the Network

- Recording action can be triggered in round-the-clock mode or event mode of VMD (Video Motion Detection) and DI
- Record video in AVI format—compatible with popular media players
- Dynamically adjust recording frame rate over the LAN/Internet to match the real frame transmit speed, to keep the video synchronized with the actual time
- Recorded video format can be selected as adjustable FPS MJPEG, or MPEG4 standard, for VPort MJPEG video servers
- Recyclable override of hard disk space in FIFO (First-In-First-Out) sequence
- Recorded video files can be stored on a local PC or Windows-based networked storage server



Schedule Jobs for Recording and Remote Service

- Administrators can set up the time schedule of remote service and the recording action for each camera

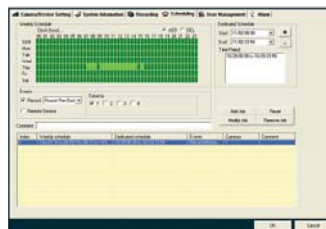

Trigger and Send Alarm Messages

- Area-selectable Video Motion Detection (VMD) function for each camera
- Sensitivity tuning for the VMD
- Alarm can be triggered by VMD, video lost, communication failure, storage failure, storage full, DIs, and then sent by email, or trigger relays (DOs), sound, or a PTZ camera to a preset position

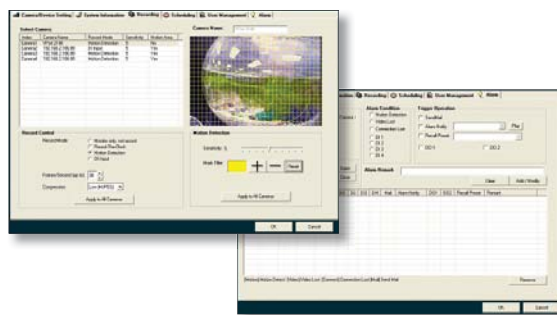

Video Server Configuration and System Management

- Can configure each camera's name, video quality, and video resolution separately
- Supports PTZ camera controls (same as VPort series video servers' support list)
- Supports Moxa's VPort series of video servers
- Up to 32 users can be added to one system
- Supports remote VPort's firmware upgrade
- Can set up the camera view and system operation for each user
- Automatically resume viewing and recording after system reboot
- Cameras can be managed easily with your own e-map

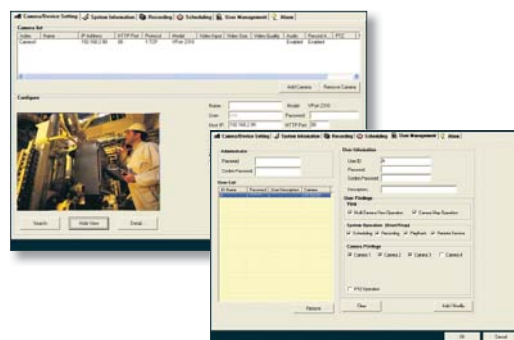

: System Requirements

Operating System: MS Windows XP

SDRAM: 1 GB or more

DirectX: 9.0C or above

Intel Dual Core: 2.0 GHz or more

Nvidia GeForce or ATI TNT2 Graphics Card: At least 64 MB of display memory required

: Ordering Information

Available Models

SoftDVR™ Pro: 16-channel IP surveillance software for viewing and recording

Package Checklist

SoftDVR™ Pro CD: Includes the SoftDVR™ Pro software, SQL database software, and user's manual

Key Pro: Plugs into the USB port

Printed Manual: Moxa SoftDVR™ Pro Quick Installation Guide

SoftDVR™ Lite Bundled FREE with VPort Series Video Servers

- 1 to 4-ch (Quad) viewing format; max. 4 cameras
- Supports viewing and recording on local PCs
- Full image VMD with sensitivity tuning
- Schedule jobs for recording
- System requirements:
 - MS Windows XP
 - 512 MB SDRAM or above
 - Nvidia GeForce or ATI TNT2 graphics card with 32 MB display memory or above
 - Intel Pentium 4 , 2.4 GHz HT (Hyper-Threading) or above
 - DirectX 9.0C or above



VPort SDK PLUS

User-friendly software development kits for third-party developers to customize video-over-IP management systems

: Introduction

Moxa IVN (Industrial Video Networking) solutions, which include VPort series video servers and SoftDVR™ IP surveillance software, are future-proof, ready-to-use video-over-IP solutions for video surveillance applications. With the growing popularity of IP networks, more and more users need to integrate their video management system with other monitoring and control systems (e.g., SCADA

or HMI) to get the benefits of centralization and inter-operation. To assist third-party developers with this intergration, we are providing Moxa VPort SDK PLUS, which supports VPort 25/251/254/351/354 and future products, for building customized video management systems and for integrating VPort series products into comprehensive monitoring and control systems.

URL Commands

URL commands are easy-to-use CGI commands used with HTML programming for web systems. Users can acquire video images and control VPort series products from their own customized web pages

by embedding these CGI commands into the HTML source code. All of the URL commands are listed in the VPort user's manual, or a CGI command manual.

ActiveX Control SDK PLUS

Sample code available

ActiveX Control is an OCX component that uses Microsoft COM (Component Object Model) technology to enable software components to communicate. ActiveX Control is used widely with platforms that support WIN32, IE Plug-in, and Visual Basic, and is also popular in automation system software, such as SCADA. Moxa ActiveX Control SDK PLUS is a user-friendly, customized tool for programmers that supports versatile parameters for customized viewing, recording, PTZ camera control, event triggering, and recorded video playback. Moxa ActiveX Control SDK PLUS is provided free of charge, and supports VB, VC, and C# developing environments, as well as plug-ins for web applications and automation tools (e.g., SCADA software). Third-party developers who want to use ActiveX SDK can download it from Moxa's website.

ActiveX Work Process

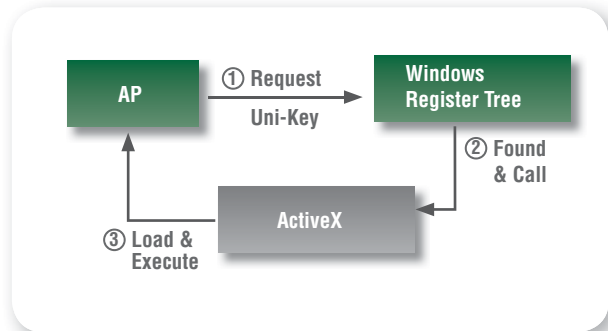

API SDK PLUS

Sample code available

For some video management applications, ActiveX Control SDK PLUS may not provide users with enough functionality. In this case, API SDK PLUS, which includes a detailed C library, can be used to program customized solutions in a Visual C++ or C# environment. API SDK PLUS includes a total of 4 DLL modules, and currently supports the WIN32, Linux, and WIN CE pocket 2003 platforms. API SDK

PLUS is provided free of charge. However, since API SDK PLUS uses proprietary technology and the programmer must be an experienced, professional C programmer, we are not releasing API SDK PLUS for general use. Third-party developers who would like to use API SDK PLUS should request support on Moxa's website to apply for a free copy. Some verification is required.

API Module Structure

