

General Standards Corporation

High Performance Bus Interface Solutions

PMC66-16AO16

16-Channel 16-Bit Differential High-Speed PMC Analog Output Board
With 450,000 Samples per Second per Channel, and 66 MHz PCI Support



Available also in PCI, cPCI and PC104-Plus form factors as:

PCI66-16AO16: PCI, short length
cPCI66-16AO16: cPCI, 3U
PC104P66-16AO16: PC104-Plus

See Ordering Information for details.

Features Include:

- 16 Precision 3-Wire Balanced Differential High-Speed Analog Output Channels
- 16-Bit Resolution; D/A Converter per Channel
- 66MHz PCI Bus Support
- Data Rates to 450K Samples per Second per Channel; 7.2 MSPS Aggregate Rate
- Software-Selectable Output Ranges of $\pm 10V$, $\pm 5V$, $\pm 2.5V$ or $\pm 1.25V$
- Optional 2-Wire Single-Ended Analog Outputs
- 256K-Sample Output Data FIFO Buffer; Configurable as Open or Circular
- Simultaneous or Sequential Output Clocking
- Multiboard Synchronization Supported
- Continuous and Burst (One-Shot) Output Modes Support Seamless Waveform Sequencing
- Data Rate Controlled Internally or Externally
- Software-Selectable Differential Clock I/O for Synchronizing Sigma-Delta A/D Boards
- High Accuracy Ensured by On-Demand Autocalibration of all Channels
- Remote Ground Sensing
- Available on Adapters for Alternate Form Factors: PCI, cPCI, PC104-Plus

Applications Include:

- ✓ Precision Voltage Source
- ✓ Acoustic Research
- ✓ Waveform Synthesis
- ✓ Audio Synthesis
- ✓ Process Control
- ✓ Industrial Robotics

REV: 031406

General Standards Corporation

8302A Whitesburg Drive · Huntsville, AL 35802

Phone: (256) 880-8787 or (800) 653-9970 FAX: (256) 880-8788 Email: Solutions@GeneralStandards.com

Overview:

The PMC66-16AO16 board contains sixteen 16-bit D/A converters (DAC's), and all supporting functions necessary for adding precision high-speed differential or single-ended analog output capability to a PMC, PCI, cPCI or PC104-Plus application. Output ranges are software-selectable as ± 10 Volts, ± 5 Volts or ± 2.5 Volts. The board is functionally compatible with the IEEE PCI local bus specification Revision 2.3, and supports both 66MHz and 33MHz PCI bus speeds with universal signaling. Unique FIFO buffer controls support the seamless sequencing of successive waveforms through a single buffer port. In less demanding applications, the outputs can be updated individually. Hardware clock I/O permits synchronization with a variety of GSC products, including Sigma-Delta ADC boards.

A PCI interface adapter provides the interface between the controlling PCI bus and the internal local controller (Figure 1). Sixteen output channels are controlled through an analog output FIFO buffer, and can be updated either simultaneously or sequentially. The output sample rate can be controlled by an internal rate generator or by an external clock. The local controller manages all input/output configuration and data manipulation functions, including autocalibration. Analog output levels are initialized to zero (midrange). Multiboard synchronization is supported.

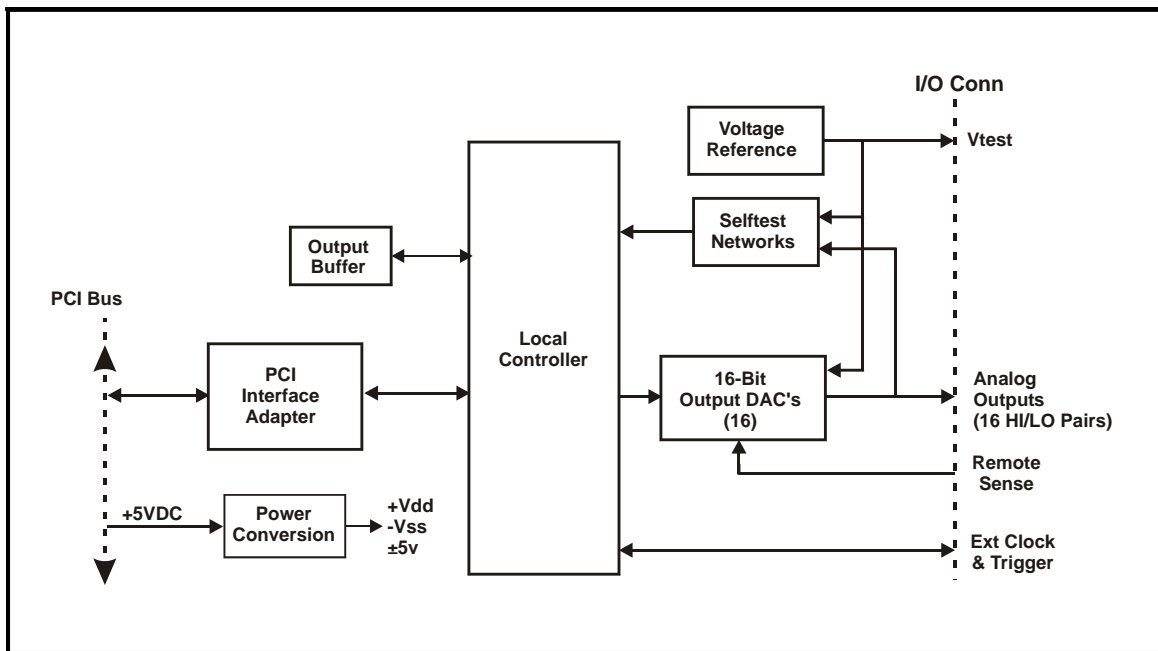

Figure 1. PMC66-16AO16 Board; Functional Organization

This product is designed for minimum off-line maintenance. On-demand autocalibration eliminates the need for disconnecting or removing the module from the system for calibration. All analog input and output system connections are made through a single 68-pin I/O connector. Power requirements consist of +5 VDC, in compliance with the PCI specification, and operation over the specified temperature range is achieved with conventional convection cooling.

Electrical Specifications

(At +25 °C, with specified operating conditions)

Analog Output Channels

Output Characteristics:

Configuration:	Sixteen 3-wire balanced differential analog output channels, with a dedicated 16-Bit DAC per channel. Each 3-Wire output consists of complementary 'HI' and 'LO' signal lines, with 'output return' as the center (balance) reference. All output returns are electrically common internally. Optional 12-channel and 8-Channel configurations are available, as well as 2-wire single-ended analog outputs.
Voltage Ranges:	Software-selected as $\pm 10V$, $\pm 5V$, $\pm 2.5V$ or $\pm 1.25V$, Line-to-Line for differential configuration. Line-to-Ground with Single-Ended option (Output-HI relative to output return). See Ordering information.
Output Resistance:	1.0 Ohm maximum
Protection:	Withstands sustained short-circuiting to ground without damage
Load Current:	± 3 ma maximum; ± 2 ma recommended for minimum crosstalk and line loss
Load Capacitance:	Stable with zero to 10,000 pF shunt capacitance; all ranges, all loads.
Settling Time (Typical):	No Filter : 5 us to 0.1%, 8 us to 0.01% 100 kHz Filter: 14 us to 0.1%, 18 us to 0.01% 10 kHz Filter: 100 us to 0.1%, 140 us to 0.01%
Noise:	No Filter: 1.3 mVRMS, 10Hz-10MHz 10 kHz Filter: 0.4 mVRMS, 10Hz-10MHz
Glitch Impulse:	$\pm 2.5V$ Range: 3 nV-Sec max.. $\pm 10V$ Range: 8 nV-Sec
Remote Sensing:	Single input pin compensates for ground potential at load.. Max range $\pm 1.0V$. Enabled or disabled through application software. Correction ± 1 percent. Input resistance: 15K typical.

Transfer Characteristics:

Resolution:	16 Bits (0.0015 percent of FSR)															
Sample Clocking Rate:	Internal Rate Clock: 172 to 450,000 samples per second per channel External Rate Clock: 0 to 450,000 samples per second per channel															
DC Accuracy, Line-Line: (Max error, no-load)	<table><thead><tr><th>Range</th><th>Midscale Accuracy</th><th>\pmFullscale Accuracy</th></tr></thead><tbody><tr><td>$\pm 10V$</td><td>$\pm 2.4mv$</td><td>$\pm 3.3mv$</td></tr><tr><td>$\pm 5V$</td><td>$\pm 1.7mv$</td><td>$\pm 2.2mv$</td></tr><tr><td>$\pm 2.5V$</td><td>$\pm 1.4mv$</td><td>$\pm 1.6mv$</td></tr><tr><td>$\pm 1.25V$</td><td>$\pm 1.2mv$</td><td>$\pm 1.4mv$</td></tr></tbody></table>	Range	Midscale Accuracy	\pm Fullscale Accuracy	$\pm 10V$	$\pm 2.4mv$	$\pm 3.3mv$	$\pm 5V$	$\pm 1.7mv$	$\pm 2.2mv$	$\pm 2.5V$	$\pm 1.4mv$	$\pm 1.6mv$	$\pm 1.25V$	$\pm 1.2mv$	$\pm 1.4mv$
Range	Midscale Accuracy	\pm Fullscale Accuracy														
$\pm 10V$	$\pm 2.4mv$	$\pm 3.3mv$														
$\pm 5V$	$\pm 1.7mv$	$\pm 2.2mv$														
$\pm 2.5V$	$\pm 1.4mv$	$\pm 1.6mv$														
$\pm 1.25V$	$\pm 1.2mv$	$\pm 1.4mv$														
Output Balance:	10mV maximum HI/LO unbalance.															
Bandwidth	10 kHz, 100 kHz and No-Filter (>300 kHz) options, Typical at -3dB. (Single-pole lowpass)															
Crosstalk Rejection:	80 dB minimum, DC-50 kHz															
Integral Nonlinearity:	± 0.007 percent of FSR, maximum															
Differential Nonlinearity:	± 0.003 percent of FSR, maximum															

Operating Modes and Control

DAC Clocking Source:	Internal rate generator, external hardware input, or software clock. The internal rate generator is software-controlled with 0.2% setting resolution, and $\pm 0.02\%$ accuracy.
Multiboard Clocking Configurations:	To support the simultaneous clocking of DAC outputs on multiple boards, the 16AO16 can be software-designated as either a clock initiator or a clock target. Initiators provide an output clock for target boards, each of which can retransmit the clock signal to subsequent boards connected in a daisy-chain configuration.
Burst Trigger:	Software control bit, or external TTL/LVDS trigger input (Same as clock I/O option). Burst triggering also can be obtained from an external source.
Update Mode:	Simultaneous or channel-sequential output updating
Active Buffer Size:	From 8 output values to 256K-values, in 2:1 steps, software-selectable.
Buffer Mode:	Selected as Circular for periodic waveforms, or as Open for one-shot functions
Data Format:	Software selected as Offset Binary or Two's complement

PCI Compatibility

Conforms to PCI Specification 2.3, with 66 MHz or 33 MHz bus and D32 read/write transactions.
Universal I/O supports both 3.3V and 5V signaling.
Multifunction interrupt.
Supports block-mode DMA transfers as bus master.

Power, Mechanical and Environmental Specifications

Power Requirements:

+5VDC ± 0.25 VDC at 1.5Amps maximum, 1.1 Amp typical. Outputs fully loaded.
Power Dissipation: 7.5 Watts max; 5.5 Watts typical

*Mechanical Characteristics: **

Height: 13.5 mm (0.53 in)
Depth: 149.0 mm (5.87 in)
Width: 74.0 mm (2.91 in)
Shield: Side-1 is protected by an EMI shield.

* Mechanical dimensions are shown for the native PMC form factor. See Ordering Information.

Power, Mechanical and Environmental Specifications (Continued)

Environmental Requirements:

Ambient Temperature Range :	Operating: 0 to +65 degrees Celsius inlet air Storage: -40 to +85 degrees Celsius
Relative Humidity:	Operating: 0 to 80%, non-condensing Storage: 0 to 95%, non-condensing
Altitude:	Operation to 10,000 ft.
Cooling:	Conventional convection cooling.

Ordering Information

Specify the basic model number followed by an option suffix "-A-B", as indicated below. For example, model number PMC66-16AO16-12-F10 describes a PMC module with 12 differential output channels and 10 kHz output filters.

Basic Model Number	Form Factor
PMC66-16AO16	PMC (Native)
PCI66-16AO16 *	PCI, short length
cPCI66-16AO16 *	cPCI, 3U
PC104P66-16AO16 **	PC104-Plus

* PMC module installed and tested on an adapter, with mechanical and functional equivalency.

** PMC module installed and tested on an adapter, with functional equivalency.

Contact factory for availability in native form factors.

Optional Parameter	Value	Specify Option As:
Number of Output Channels:	8 Channels	A = 8
	12 Channels	A = 12
	16 Channels	A = 16
Output Lowpass Filter: (Single-pole)	No output Filters (>300kHz)	B = F0
	10 kHz Output Filters	B = F10
	100 kHz Output Filters	B = F100
Output Configuration:	Differential	C = DF
	Single-Ended	C = SE

System I/O Connections

I/O CONNECTOR PIN ASSIGNMENTS

ROW-A		ROW-B	
PIN	FUNCTION	PIN	FUNCTION
1	OUTPUT 00 LO	1	OUTPUT 09 LO
2	OUTPUT 00 HI	2	OUTPUT 09 HI
3	OUTPUT RETURN	3	OUTPUT 10 LO
4	OUTPUT RETURN	4	OUTPUT 10 HI
5	OUTPUT 01 LO	5	OUTPUT RETURN
6	OUTPUT 01 HI	6	OUTPUT RETURN
7	OUTPUT RETURN	7	OUTPUT 11 LO
8	OUTPUT RETURN	8	OUTPUT 11 HI
9	OUTPUT 02 LO	9	OUTPUT 12 LO
10	OUTPUT 02 HI	10	OUTPUT 12 HI
11	OUTPUT RETURN	11	OUTPUT RETURN
12	OUTPUT RETURN	12	OUTPUT RETURN
13	OUTPUT 03 LO	13	OUTPUT 13 LO
14	OUTPUT 03 HI	14	OUTPUT 13 HI
15	OUTPUT RETURN	15	OUTPUT 14 LO
16	OUTPUT RETURN	16	OUTPUT 14 HI
17	OUTPUT 04 LO	17	OUTPUT RETURN
18	OUTPUT 04 HI	18	OUTPUT RETURN
19	OUTPUT RETURN	19	OUTPUT 15 LO
20	OUTPUT RETURN	20	OUTPUT 15 HI
21	OUTPUT 05 LO	21	OUTPUT RETURN
22	OUTPUT 05 HI	22	REM GND SENSE
23	OUTPUT RETURN	23	OUTPUT RETURN
24	OUTPUT RETURN	24	VTEST OUT
25	OUTPUT 06 LO	25	VTEST RETURN
26	OUTPUT 06 HI	26	DIGITAL RETURN
27	OUTPUT RETURN	27	TRIG IN HI *
28	OUTPUT RETURN	28	TRIG IN LO *
29	OUTPUT 07 LO	29	TRIG OUT HI *
30	OUTPUT 07 HI	30	TRIG OUT LO *
31	OUTPUT RETURN	31	DAC CLK OUT HI *
32	OUTPUT RETURN	32	DAC CLK OUT LO *
33	OUTPUT 08 LO	33	CLOCK I/O HI **
34	OUTPUT 08 HI	34	CLOCK I/O LO **

The differential analog output configuration is shown. For optional single-ended outputs, OUTPUT XX HI is an output, and OUTPUT XX LO is not used.

* Software-selectable as LVDS differential pairs. In TTL mode, 'HI' pins are signal pins, and 'LO' inputs should be connected to digital return.

** Bidirectional synchronization signal.

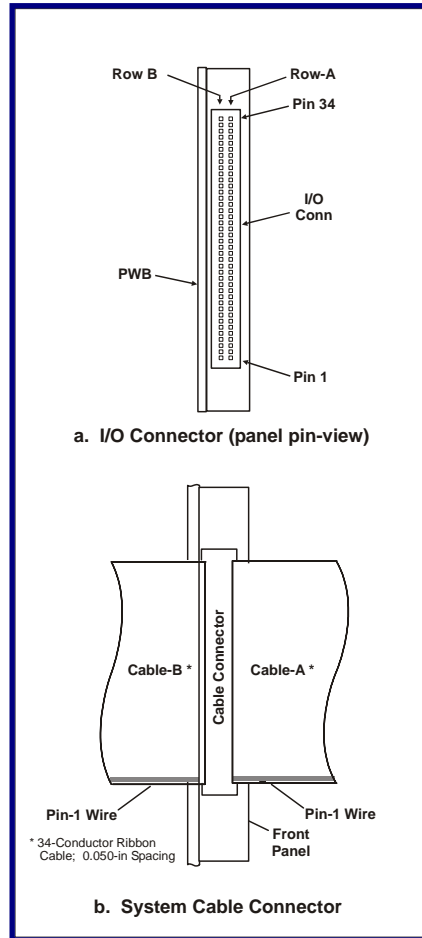

Figure 2. System I/O Connector

System Cable Mating Connector:

68-pin 0.050" Subminiature connector: with metal shield:
AMP #749621-7 or equivalent.

I/O Connector Installed on Board (Ref):

Amp # 787170-7

Channels available in 8-Channel and 12-Channel configurations:

8-Channel Board: Channels 00-07,
12-Channel board: Channels 00-11.

General Standards Corporation assumes no responsibility for the use of any circuits in this product. No circuit patent licenses are implied. Information included herein supersedes previously published specifications on this product and is subject to change without notice.