

General Standards Corporation

High Performance Bus Interface Solutions

PMC-24DSI12

12-Channel 24-Bit Delta-Sigma PMC Analog Input Board

With 200 KSPS Sample Rate per Channel

Available also in PCI, cPCI and PC104-Plus form factors as:

PCI-24DSI12:	PCI, short length
cPCI-24DSI12:	cPCI, 3U
PC104--24DSI12:	PC104-Plus

See Ordering Information for details.

FEATURES:

- ♦ **12 Differential 24-Bit Analog Input Channels**
- ♦ **Delta-Sigma Converter per Channel, with Linear Phase Digital Antialias Filtering**
- ♦ **Sample rates from 2 KSPS to 200 KSPS per Channel**
- ♦ **Software-Selectable Input Ranges: $\pm 2.5V$, $\pm 5V$, $\pm 10V$**
- ♦ 256 K-sample FIFO Buffer
- ♦ Synchronous or Independent ADC Clocking
- ♦ Internal Sample Rate Generators
- ♦ Hardware Sync and Clock I/O for Multiboard Synchronization
- ♦ Low Phase Skew; Typically Less than 55ns with $F_{sig} < 0.35 * F_{samp}$
- ♦ DMA Engine Supports both Block-Mode and Demand-Mode Transfers
- ♦ Low Power Consumption. 6 Watts Typical. Only +5VDC Required from PCI bus.
- ♦ 100dB Dynamic Range to 100KSPS; 93 dB SINAD
- ♦ On-demand Autocalibration Ensures DC Precision as well as AC performance
- ♦ Integrated DC/DC Conversion and Regulation of Precision Internal Supply Voltages
- ♦ Conforms to PCI Bus Specification, Revision 2.3, with Universal Signaling
- ♦ Available on Adapters for Alternate Form Factors: PCI, cPCI, PC104-Plus

TYPICAL APPLICATIONS:

- | | | |
|-----------------|-----------------------|---------------------------|
| ✓ Sonar Arrays | ✓ Voltage Acquisition | ✓ Phase Comparison |
| ✓ Analog Inputs | ✓ Acoustic Research | ✓ Audio Waveform Analysis |

REV 090406

General Standards Corporation

8302A Whitesburg Drive · Huntsville, AL 35802

Phone: (256) 880-8787 or (800) 653-9970 FAX: (256) 880-8788 Email: Solutions@GeneralStandards.com

Overview:

The 12-channel PMC-24DSI12 analog input board provides high-density 24-bit analog input resources on a standard single-width PMC. Optimized for flexibility and performance, the board is ideal for a wide variety of applications, ranging from simple precision voltage measurements, to the analysis of complex audio signals and waveforms.

Functional Description:

Each of 12 analog input channels contains a lowpass image filter, and a delta-sigma A/D converter that provides digital antialias filtering. An internal voltage reference can be applied to all channels to support self-test operations and autocalibration. Gain and offset trimming is performed by applying correction values that are determined during on-demand autocalibration. A linear-phase digital antialiasing filter rejects out-of-band signals, and a lowpass analog filter reject those interference signals that fall within the harmonic images of the digital filter.

An internal sample-rate generator is adjustable over a 2:1 frequency range, and is divided down within the local controller to provide individual channel sample rates from 2KSPS to 200KSPS. Conversion data from all active channels is transferred to the PCI bus through a 256K-sample data buffer that is supported by two DMA channels. Multiple channels can be synchronized to perform sampling in "lockstep", either by a software command, or by external hardware sync and clock input signals.

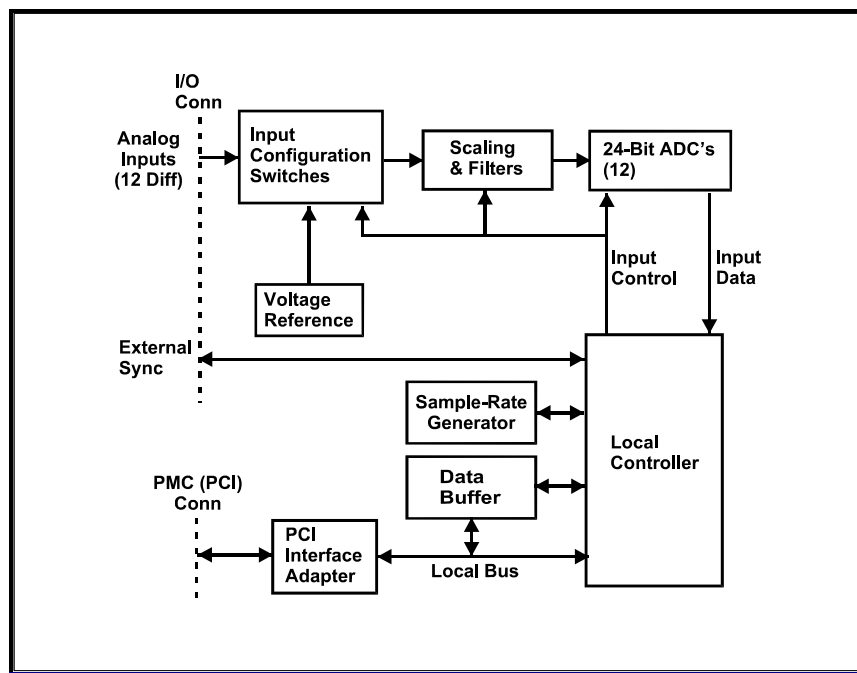

Figure 1. PMC-24DSI12; Functional Organization

This product is functionally compatible with the IEEE PCI local bus specification Revision 2.3. System input/output connections are made at the front panel through a high-density 68-Pin I/O connector. Power requirements consist of +5 VDC, in compliance with the PCI specification, and operation over the specified temperature range is achieved with conventional 200 LFPM air cooling.

ELECTRICAL SPECIFICATIONS

At +25 °C, with specified operating conditions.

Input Characteristics:

Configuration:	12 differential input channels. 8 and 4-channel configurations available.
Voltage Range:	Software Configurable as ± 2.5 Volts, ± 5 Volts or ± 10 Volts
Input Impedance:	1.0 Megohm typical, in parallel with 20 pF. 2.0 Megohms line-line.
Common Mode Rejection:	80dB to 1kHz; 60dB to 50kHz.; typical
Common Mode Range:	± 11 Volts with zero normal-mode input
Overvoltage Protection:	± 25 -Volt transients with power applied; ± 45 Volts with power removed

Transfer Characteristics:

Quantizing Resolution:	24 Bits				
Sample Rate:	2,000 to 200,000 samples per second per channel				
Oversampling Factor:	2-50ksps: x128; 50-100ksps: x64; 100-200ksps: x32				
DC Accuracy: (Mean composite error after autocalibration)	Input Range	Midrange (Zero) Accuracy	Gain Accuracy at Fsamp		
	$\pm 10V$	$\pm 0.5mv$	2-4ksps $\pm 0.9\%$	4-15ksps $\pm 0.3\%$	15-200ksps $\pm 0.1\%$
	$\pm 5V$	$\pm 0.3mv$	$\pm 0.9\%$	$\pm 0.3\%$	$\pm 0.1\%$
	$\pm 2.5V$	$\pm 0.1mv$	$\pm 0.9\%$	$\pm 0.3\%$	$\pm 0.1\%$
Bandwidth (-3dB)	DC to typically 49 percent of selected sample rate for sample rates to 100KSPS, or to 35 percent of sample rate from 100kSPS to 200KSPS. Typically DC to 70 kHz overall. 0.1dB to 0.45Fsamp; 2-100KSPS; 0.24Fsamp 100-200KSPS.				
Passband Ripple:	± 0.06 dB maximum				
Phase Skew:	Typically less than 55ns (0.1-Degree for Fsig = 5kHz), with Fsig/Fsmp < 0.35; channel-channel (board-board for multiboard configurations), excluding noise, with high-frequency image filter.				
ADC Stopband:	Sample Rate:	Threshold*	Rejection*		
	2-50KSPS:	0.58 Fsamp	93dB		
	50-100KSPS:	0.68 Fsamp	90dB		
	100-200KSPS:	0.78 Fsamp	95dB		
	* Typical values. (Fsamp = sample rate)				
Antialias Filtering:	Each ADC provides linear-phase digital antialias filtering as indicated for "ADC Stopband." A 2-pole Butterworth lowpass analog filter in each channel provides a software-selected cutoff frequency of either 40kHz or 270kHz, and suppresses images from the digital filter. Optional alternative filter frequencies are available.				
Dynamic Range:	100dB; typical 2 KSPS to 100 KSPS; 80dB from 100ksps to 200ksps.				
SINAD:	(Signal to Noise-and-Distortion ratio): 93dB typical to 10 kHz input bandwidth; 85 dB typical to 50 kHz.				
Interchannel Crosstalk:	-96dB typical to 50kHz				

Operating Modes and Controls:

Organization:	Two analog input channel groups. All channels in each group1 operate at the same sample rate, which is further controlled by division of the selected rate generator frequency. Each channel group contains one-half of the channels on the board, and can operate either synchronously from a single rate generator, or independently from either of two generators.
Sample Rate Generators:	Two independent internal PLL rate generators provide sample rates from 2.0 KSPS to 200 KSPS. The frequency of each generator is controlled by the ratio of two 10-Bit integers, and setting accuracy is 25 PPM. Older (legacy) products control each rate generator with a single integer, and are not recommended for new applications. This version will remain available however, as an ordering option.
External Clock I/O:	An LVDS or TTL hardware input clock can be derived either from a 25.6-51.2 MHz external hardware input or from an internal rate generator. Multiple boards can be locked to a common clock by daisy-chaining the output clock from each board to the input clock of the next board in the chain. Any number of boards can be daisy-chained together, with a typical propagation delay of 10ns introduced per board. The 'star-configuration' also is supported.
Synchronization:	Sampling of multiple channel groups can be phase-synchronized through software, or each group can be synchronized to an external hardware clock input. Daisy-chained hardware sync inputs and outputs can be used to synchronize sampling among multiple boards.
Data Format:	Software-selectable as either offset binary or two's complement. Width of the data-field is selectable as 16, 18, 20 or 24 bits.
Channel Tags:	A 4-bit channel tag is appended to each input data value.
Buffer Threshold Flag:	Asserted when the number of samples in the selected buffer exceeds the selected threshold. The threshold can be any integer from zero to 3 FFFEh.
Buffer Access:	The input buffer FIFO is accessed through either of two DMA channels, with both block-mode and demand-mode transfers supported.

PCI Compatibility:

- Conforms to PCI Specification 2.3: D32, 33MHz, universal (3.3V/5V) signaling.
- Supports "plug-n-play" initialization.
- Single multifunction interrupt on INTA#.
- Two-Channel DMA as bus master in block and demand modes.

Power Requirements:

- +5.0 VDC \pm 0.25 VDC at 1.2 Amps typical, 1.5 Amps, maximum
- Maximum Power Dissipation: Side-1: 6.5 Watts. Side 2: 1.0 Watt.

Mechanical Characteristics:

(HxWxD): 13.5 mm (0.53 in) x 74.0 mm (2.91 in) x 149.0 mm (5.87 in)

(Mechanical dimensions are shown for the native PMC form factor. See Ordering Information.)

Environmental Specifications:

Ambient Temperature Range: Operating: Standard: 0 to +65 degrees Celsius inlet air
 Extended: -40 to +80 degrees Celsius inlet air
 Storage: -40 to +85 degrees Celsius.

Relative Humidity: Operating: 0 to 80%, non-condensing
 Storage: 0 to 95%, non-condensing

Altitude: Operation to 10,000 ft.

Cooling: Conventional convection cooling; 150 LFPM

Ordering Information:

Specify the basic product model number followed by an option suffix "-A-B-C", as indicated below. For example, model number PMC-24DSI12-12-SF describes a PMC module with 12 input channels, standard lowpass analog filter frequencies and standard operating temperature range.

Basic Model Number	Form Factor
PMC-24DSI12	PMC (Native)
PCI-24DSI12 *	PCI, short length
cPCI-24DSI12 *	cPCI, 3U
PC104P-24DSI	PC104-Plus (Native)

* PMC module installed and tested on an adapter, with mechanical and functional equivalency. Contact factory for availability in native form factors.

Optional Parameter	Value	Specify Option As:
Number of Input Channels	4 Channels	A = 4
	8 Channels	A = 8
	12 Channels	A = 12
Lowpass Filter Frequencies	Standard 40kHz and 270kHz	B = SF
	Custom Frequencies	B = CF *
Operating Temperature	Standard Range: 0 to +65 Deg-C	C = S (or Blank)
	Extended Range: -40 to +80 Deg-C	C = ET *
Rate Generator	Legacy rate generator	D = L (or Blank)
	PLL Rate Generator (recommended)	D = PLL

* Contact factory for availability.

General Standards Corporation

8302A Whitesburg Drive · Huntsville, AL 35802

Phone: (256) 880-8787 or (800) 653-9970 FAX: (256) 880-8788 Email: Solutions@GeneralStandards.com

SYSTEM I/O CONNECTIONS

I/O CONNECTOR PIN ASSIGNMENTS

ROW-A		ROW-B	
PIN	FUNCTION	PIN	FUNCTION
1	INPUT RETURN	1	INPUT RETURN
2	INPUT RETURN	2	INPUT RETURN
3	INP CHAN 00 LO	3	INP CHAN 06 LO
4	INP CHAN 00 HI	4	INP CHAN 06 HI
5	INPUT RETURN	5	INPUT RETURN
6	INPUT RETURN	6	INPUT RETURN
7	INP CHAN 01 LO	7	INP CHAN 07 LO
8	INP CHAN 01 HI	8	INP CHAN 07 HI
9	INPUT RETURN	9	INPUT RETURN
10	INPUT RETURN	10	INPUT RETURN
11	INP CHAN 02 LO	11	INP CHAN 08 LO
12	INP CHAN 02 HI	12	INP CHAN 08 HI
13	INPUT RETURN	13	INPUT RETURN
14	INPUT RETURN	14	INPUT RETURN
15	INP CHAN 03 LO	15	INP CHAN 09 LO
16	INP CHAN 03 HI	16	INP CHAN 09 HI
17	INPUT RETURN	17	INPUT RETURN
18	INPUT RETURN	18	INPUT RETURN
19	INP CHAN 04 LO	19	INP CHAN 10 LO
20	INP CHAN 04 HI	20	INP CHAN 10 HI
21	INPUT RETURN	21	INPUT RETURN
22	INPUT RETURN	22	INPUT RETURN
23	INP CHAN 05 LO	23	INP CHAN 11 LO
24	INP CHAN 05 HI	24	INP CHAN 11 HI
25	VTEST RETURN	25	INPUT RETURN
26	VTEST	26	INPUT RETURN
27	DIGITAL RETURN	27	DIGITAL RETURN
28	DIGITAL RETURN	28	DIGITAL RETURN
29	EXT CLK INP LO	29	EXT CLK OUT LO
30	EXT CLK INP HI *	30	EXT CLK OUT HI *
31	DIGITAL RETURN	31	DIGITAL RETURN
32	DIGITAL RETURN	32	DIGITAL RETURN
33	EXT SYNC INP LO	33	EXT SYNC OUT LO
34	EXT SYNC INP HI *	34	EXT SYNC OUT HI *

* TTL signal levels when TTL sync I/O is selected.

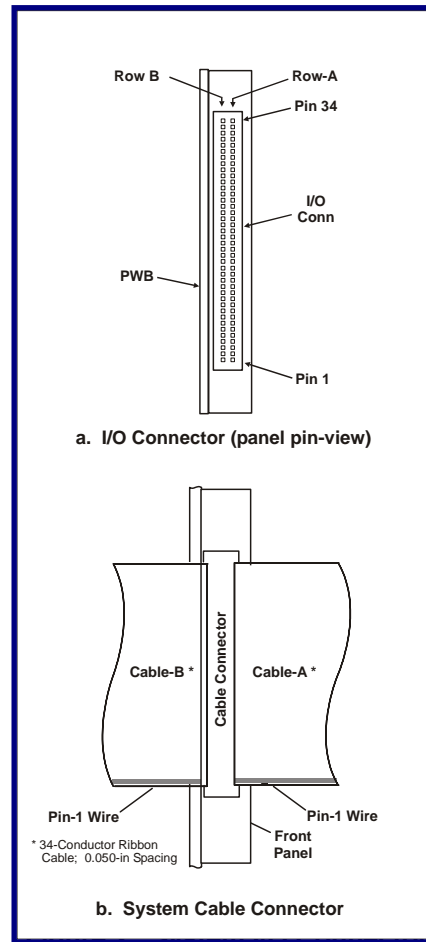

System Cable Mating Connector:

68-pin 0.050" Subminiature connector: with metal shield:
AMP #749621-7 or equivalent.

I/O Connector Installed on Board (Ref):

Amp # 787170-7

General Standards Corporation assumes no responsibility for the use of any circuits in this product. No circuit patent licenses are implied. Information included herein supersedes previously published specifications on this product and is subject to change without notice.

General Standards Corporation

8302A Whitesburg Drive · Huntsville, AL 35802

Phone: (256) 880-8787 or (800) 653-9970 FAX: (256) 880-8788 Email: Solutions@GeneralStandards.com