

General Standards Corporation

High Performance Bus Interface Solutions

PMC-16AI088

16-Channel 16-Bit PMC Analog I/O Board

With 8 Input Channels, 8 Output Channels, and Autocalibration

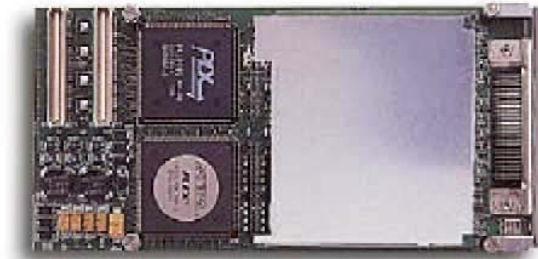

Features

- Eight 16-Bit Analog Output Channels with 16-Bit D/A Converter per Channel
- Eight 16-Bit Analog Input Channels with 8 Single-Ended or 4 Differential Inputs
- Input and Output Ranges available as $\pm 10V$, $\pm 5V$ or $\pm 2.5V$
- Input and Output FIFO Buffers; 32K-Sample Input, 16K-Sample Output Capacity
- ADC Inputs Scanned at up to 73 KSPS Aggregate Rate; 9.5-16.2 KSPS per Channel
- Aggregate Analog Output Data Rates to 250K Channels per Second
- Simultaneous Updating of Outputs with Hardware or Software Strobe
- Continuous and Burst Input Scanning Modes; Hardware and Software Triggering
- Programmable Rate Generator Supports Inputs and Outputs
- Autocalibration Correction Implemented in Hardware; No Missing Codes
- Supports Block-Mode and 2-Channel Demand-Mode DMA Transfers as Bus Master
- Loopback Feature for Built-in-Test Support (BITE) and Autocalibration
- Integrated Dual-Conversion Precision Power Conversion
- Single-width PMC Form Factor, with EMI shield

Typical Applications

- ✓ Data Acquisition Systems
- ✓ Industrial Robotics
- ✓ Precision Voltage Sources
- ✓ Automatic Test Equipment
- ✓ Function Generation
- ✓ Research Instrumentation

REV-032505

General Standards Corporation

8302A Whitesburg Drive · Huntsville, AL 35802

Phone: (256) 880-8787 or (800) 653-9970 FAX: (256) 880-8788 Email: Solutions@GeneralStandards.com

Functional Description

The PMC-16AIO-88 board contains eight 16-Bit D/A converters, an 8-channel 16-bit scanning A/D converter, and all supporting functions necessary for adding flexible analog I/O capability to a PMC host. The board is functionally compatible with the IEEE PCI local bus specification Revision 2.3, and supports the "plug-n-play" system initialization concept. Designed for minimum off-line maintenance, the PMC-16AIO-88 board includes internal monitoring and loopback features that eliminate the need for disconnecting or removing the module from the system for calibration. A shared programmable rate generator provides a time base for controlling either output clocking or input scanning, or permits input scanning be synchronized to the output clock. All system analog input and output connections are made through a single 50-pin subminiature-D front-access I/O connector.

Offset and gain trimming of the input and output channels is performed by calibration DAC's (Figure 1) that are loaded with channel correction values during initialization. During autocalibration, system analog inputs are replaced with either a precision voltage standard or the eight analog output channels. This arrangement is used to determine the necessary offset and gain correction values for the calibration DAC's. The correction values determined during autocalibration are stored in an EEPROM for subsequent transfer to the calibration DAC's during board initialization.

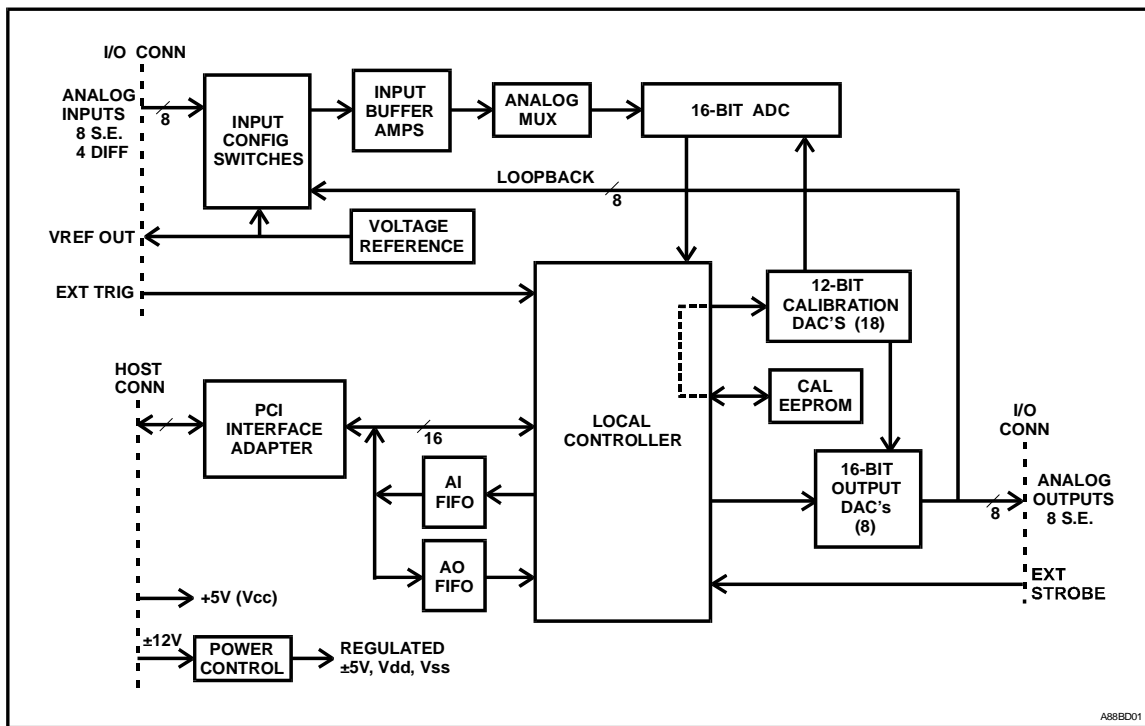

Figure 1. PMC-16AIO-88 Analog I/O Board, Simplified Functional Diagram

The board receives output data and channel identification values through an analog output (AO) buffer. Analog input conversion values are transferred to the bus through an analog input (AI) FIFO buffer. A PCI Interface Adapter provides communication with the host PCI bus, and furnishes a 16-bit local bus for exchanging information between the FIFO buffers, the adapter, and the Local Controller. The Local Controller manages all internal operations.

Performance Specifications

At +25 °C, with specified operating voltages

Analog Input Electrical Characteristics:

Configuration:	8 single-ended or 4 differential input channels; software selected
Voltage Ranges:	Factory configured as ± 10 Volts, ± 5 Volts or ± 2.5 Volts
Input Impedance:	1.0 Megohms in parallel with 20 pF
Common Mode Rejection:	80 dB minimum, DC-60 Hz (Differential mode)
Common Mode Range:	Input range plus 1.0 Volt; e.g.: ± 6 V for the ± 5 V range (Differential mode)
Offset Voltage:	± 2.0 millivolts, maximum
Noise:	2 mVRMS, 10Hz-10KHz
Remote Ground Sensing:	All single-ended inputs are measured relative to an external return
Overvoltage Protection:	± 30 Volts with power applied; ± 15 Volts with power removed

Analog Input Transfer Characteristics:

Resolution:	16 Bits (0.0015 percent of FSR)
Conversion Rate:	73KSPS (thousand samples per second), minimum in single-ended mode, 66KSPS in differential mode.
Scan Rate:	Fixed at the maximum scan rate unless the rate generator is invoked. The rate generator provides programmable scan rates from 305 scans per second, up to the maximum scan rate.
Maximum Scan Rate:	9,500 scans per second in single-ended mode; 16,200 in differential mode.
Accuracy:	± 0.007 percent of reading, ± 0.01 percent of Full-Scale-Range, ± 2.0 mV. e.g.: ± 3.3 mV, while reading +4 Volts on the ± 5 V range (10V FSR).
Crosstalk Rejection:	80dB minimum, adjacent channels; 85dB, nonadjacent channels; DC-1000Hz
Integral Nonlinearity:	± 0.006 percent of FSR, maximum
Differential Nonlinearity:	± 0.003 percent of FSR, maximum

Analog Input Operating Modes and Controls

Analog Input Modes:	Continuous Scan: Analog inputs are scanned continuously
	Burst Scan: A hardware or software trigger initiates a single scan
	Single-Ended: Eight single-ended analog input channels
	Differential: Four differential analog input channels
	Loopback: Monitors a selected output channel with the analog input
	Reference: Monitors the internal reference with the analog input

Software Burst Trigger: Initiates an input burst-scan when asserted. Active only in burst modes.
Input Data Buffer: A 16-bit FIFO buffer provides analog input conversion data to the PCI bus.
Input Buffer Flags: Input buffer empty or almost-full. Available as interrupt conditions.

Analog Output Electrical Characteristics:

Configuration: Eight single-ended output channels
Voltage Ranges: Factory configured as ± 10 Volts, ± 5 Volts or ± 2.5 Volts
Output Resistance: 1.0 Ohm, maximum
Output protection: Withstands sustained short-circuiting to ground, and overvoltage transients to ± 50 Volts through 80 Ohms for 10 milliseconds.
Load Current: ± 5 ma maximum; ± 2 ma for minimum crosstalk and line loss
Load Capacitance: Stable with zero to 2000 pF shunt capacitance
Noise: 1.2 kHz Filter: 2 mVRMS, 10Hz-10KHz
4 kHz Filter: 4 mVRMS, 10Hz-10KHz
No Filter (75 kHz): 10 mVRMS, 10Hz-10KHz

Analog Output Transfer Characteristics

Resolution: 16 Bits (0.0015 percent of FSR)
Output Sample Rate: Fixed at the maximum sample rate unless the rate generator is invoked. The rate generator provides an output strobe that updates (samples) all output channels simultaneously. The strobe rate is programmable from 305 strobes per second, up to the maximum scan rate divided by the number of active channels.
Maximum Sample Rate: 250K channels per second, aggregate rate. Host-dependent.
Accuracy (No load): ± 0.009 percent of reading, ± 0.010 percent of Full-Scale-Range, ± 1.5 mV. E.g.: ± 2.9 mV, while generating +4 Volts on the ± 5 V range (10V FSR). Add ± 1.0 mV per milliamp of loading.
Settling Time (0.01%): No output filter: 40 us
4 kHz Filter: 0.40 ms
1.2 kHz Filter: 1.50 ms
Crosstalk Rejection: 75 dB minimum, DC-1000Hz
Integral Nonlinearity: ± 0.007 percent of FSR, maximum
Differential Nonlinearity: ± 0.003 percent of FSR, maximum

Analog Output Operating Modes and Controls

Software Output Strobe: Transfers data in all output channels to the output DAC's simultaneously
Output Data Buffer: A 16-bit FIFO buffer receives analog output data and channel. Output channel number is accepted first, followed by the output value.
Buffer Flags: Buffer-full and almost-empty flags. Available as interrupt conditions.

PCI Compatibility:

- Conforms to PCI Specification 2.3, with D32, 33MHz and universal (5/3.3 Volt) signaling
- Supports "plug-n-play" initialization.
- Provides one multifunction interrupt.
- Supports DMA transfers as bus master in both block and 2-channel demand modes.

Power Requirements

- +5VDC \pm 0.2 VDC at 1.1 Amp maximum, 0.8 Amp typical.
- Maximum Power Dissipation: Side-1: 3.9 Watts. Side 2: 1.6 Watts.

Physical Parameters

- Height: 13.5 mm (0.53 in)
- Depth: 149.0 mm (5.87 in)
- Width: 74.0 mm (2.91 in)
- Shield: Side-1 is protected by an EMI shield.

Environmental Specifications

- Ambient Temperature Range: Operating: 0 to +65 Degrees Celsius inlet air
Storage: -40 to +85 Degrees Celsius
- Relative Humidity: Operating: 0 to 80%, non-condensing
Storage: 0 to 95%, non-condensing
- Altitude: Operation to 10,000 ft.
- Cooling: Conventional convection cooling; 150 LFPM

Ordering Information

Specify the basic product model number followed by an option suffix "-AB", as indicated below. For example, model number PMC-16AIO-88-32 describes a card with \pm 10 Volt input/output ranges and 1.2 kHz output filters.

Optional Parameter	Value	Specify Option As:
Input/output Range	\pm 2.5 Volts	A = 1
	\pm 5 Volts	A = 2
	\pm 10 Volts	A = 3
Output Lowpass Filter	No output Filter *	B = 1
	1.2 kHz Output Filter	B = 2
	4 kHz Output Filter	B = 3
	8 kHz Output Filter	B = 4

* Output frequency response with no output filter is approximately 75 kHz.

General Standards Corporation assumes no responsibility for the use of any circuits in this product. No circuit patent licenses are implied. Information included herein supersedes previously published specifications on this product and is subject to change without notice.

System Interface Connector

P5-A		P5-B: SINGLE-ENDED INPUTS		P5-B: DIFFERENTIAL INPUTS	
PIN	SIGNAL	PIN	SIGNAL	PIN	SIGNAL
1	OUTPUT RETURN	1	DIGITAL RETURN	1	DIGITAL RETURN
2	OUTPUT CHAN 00	2	INPUT TRIGGER	2	INPUT TRIGGER
3	OUTPUT RETURN	3	DIGITAL RETURN	3	DIGITAL RETURN
4	OUTPUT CHAN 01	4	INPUT TRIG RDY	4	INPUT TRIG RDY
5	OUTPUT RETURN	5	DIGITAL RETURN	5	DIGITAL RETURN
6	OUTPUT CHAN 02	6	DIGITAL RETURN	6	DIGITAL RETURN
7	OUTPUT RETURN	7	DIGITAL RETURN	7	DIGITAL RETURN
8	OUTPUT CHAN 03	8	(Reserved)	8	(Reserved)
9	OUTPUT RETURN	9	INPUT RETURN	9	INPUT RETURN
10	OUTPUT CHAN 04	10	INPUT CHAN 00	10	INPUT CHAN 00 HI
11	OUTPUT RETURN	11	INPUT RETURN	11	INPUT RETURN
12	OUTPUT CHAN 05	12	INPUT CHAN 01	12	INPUT CHAN 01 HI
13	OUTPUT RETURN	13	INPUT RETURN	13	INPUT RETURN
14	OUTPUT CHAN 06	14	INPUT CHAN 02	14	INPUT CHAN 02 HI
15	OUTPUT RETURN	15	INPUT RETURN	15	INPUT RETURN
16	OUTPUT CHAN 07	16	INPUT CHAN 03	16	INPUT CHAN 03 HI
17	OUTPUT RETURN	17	INPUT RETURN	17	INPUT RETURN
18	(Reserved)	18	INPUT CHAN 04	18	INPUT CHAN 00 LO
19	DIGITAL RETURN	19	INPUT RETURN	19	INPUT RETURN
20	OUTPUT STROBE	20	INPUT CHAN 05	20	INPUT CHAN 01 LO
21	DIGITAL RETURN	21	INPUT RETURN	21	INPUT RETURN
22	OUTPUT STRB RDY	22	INPUT CHAN 06	22	INPUT CHAN 02 LO
23	ADC RETURN	23	INPUT RETURN	23	INPUT RETURN
24	RANGE REFERENCE	24	INPUT CHAN 07	24	INPUT CHAN 03 LO
25	ADC RETURN	25	INPUT RETURN	25	INPUT RETURN

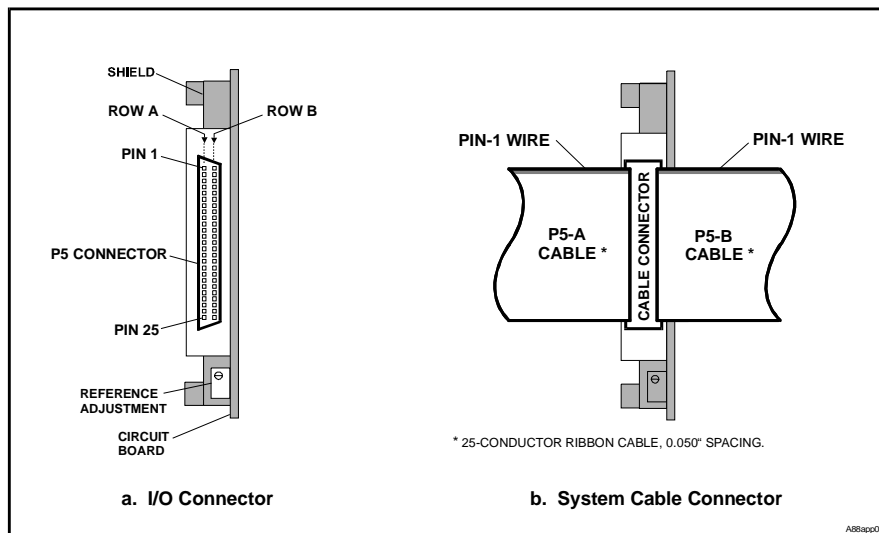

P5 Mating Cable Connector:
 Standard male 50-pin 0.05" dual-ribbon subminiature D connector,
 equivalent to AMP #1-750913-5.