

# **General Standards Corporation**

## **High Performance Bus Interface Solutions**

### ***PC104P-16AIO168***

#### **16-Bit Analog Input/Output PC104-Plus Board**

*With 16 Input Channels and 8 Output Channels*

Available also in PMC, PCI and cPCI form factors as:

<b>PMC-16AIO168:</b>	<b>PMC</b>
<b>PCI-16AIO168:</b>	<b>PCI</b> , short length
<b>cPCI-16AIO168:</b>	<b>cPCI</b> , 3U

See Ordering Information for details.

#### ***Features Include:***

- 16 Single-Ended or 8 Differential 16-Bit Scanned Analog Input Channels
- Eight Analog Output Channels, 16-Bit D/A Converter per Channel
- Software-Selectable Analog Input/Output Ranges of  $\pm 10V$ ,  $\pm 5V$  or  $\pm 2.5V$
- Independent 32K-Sample Analog Input and Output FIFO Buffers
- 300K Samples per Second Aggregate Analog Input Sample Rate
- Multiple-Channel and Single-Channel Input Scanning Modes
- Low Crosstalk, Noise and Input Bias Current; Buffer Amplifiers on all Analog Input Lines
- 300K Samples per Second per Channel Analog Output Clocking Rate
- Supports Waveform and Arbitrary Function Generation; Continuous and One-shot Modes
- Internal Rate Generator Controls Input Sampling, Output Sampling, or Both Simultaneously
- Supports Multiboard Synchronization of Analog Inputs and Outputs
- Four Auxiliary Digital Output Lines
- Internal Auto calibration of Analog Input and Output Channels
- Continuous and Burst (One-Shot) Input and Output Modes
- DMA Engine Minimizes Host I/O Overhead

#### ***Applications:***

- |   |   |
|---|---|
| <input type="checkbox"/> Data Acquisition Systems                   | <input type="checkbox"/> Automatic Test Equipment         |
| <input type="checkbox"/> Industrial Robotics                        | <input type="checkbox"/> Function and Waveform Generation |
| <input type="checkbox"/> Precision Voltage Sourcing and Measurement | <input type="checkbox"/> Research Instrumentation         |

Rev: 092807A

## **General Standards Corporation**

8302A Whitesburg Drive · Huntsville, AL 35802

Phone: (256) 880-8787 FAX: (256) 880-8788 Email [Solutions@generalstandards.com](mailto:Solutions@generalstandards.com)

# General Standards Corporation

## High Performance Bus Interface Solutions

### Functional Description:

The PC104P-16AIO168 board provides high-speed 16-bit analog input/output resources in a standard PC104-Plus module. Eight analog output channels can be updated either synchronously or asynchronously, and support waveform generation. Each analog output channel contains a dedicated 16-bit D/A converter and an output range control network. The board receives analog output data from the PCI bus through a 32K-sample FIFO buffer.

The analog inputs are software-configurable either as 16 single-ended channels or as eight differential signal pairs. Buffer amplifiers on all input lines eliminate multiplexer input switching noise, and minimize crosstalk and input bias currents. Analog input data accumulates in a 32K-sample buffer until retrieved through the PCI bus.

Internal autocalibration networks permit the calibration of all analog input and output channels without removing the board from the system. Gain and offset corrections of the analog input and output channels are performed by calibration DAC's that are loaded with channel correction values during autocalibration. Software-controlled test configurations include a loopback mode for monitoring any analog output channel. Trigger input and output connections support external triggering and multiboard synchronization.

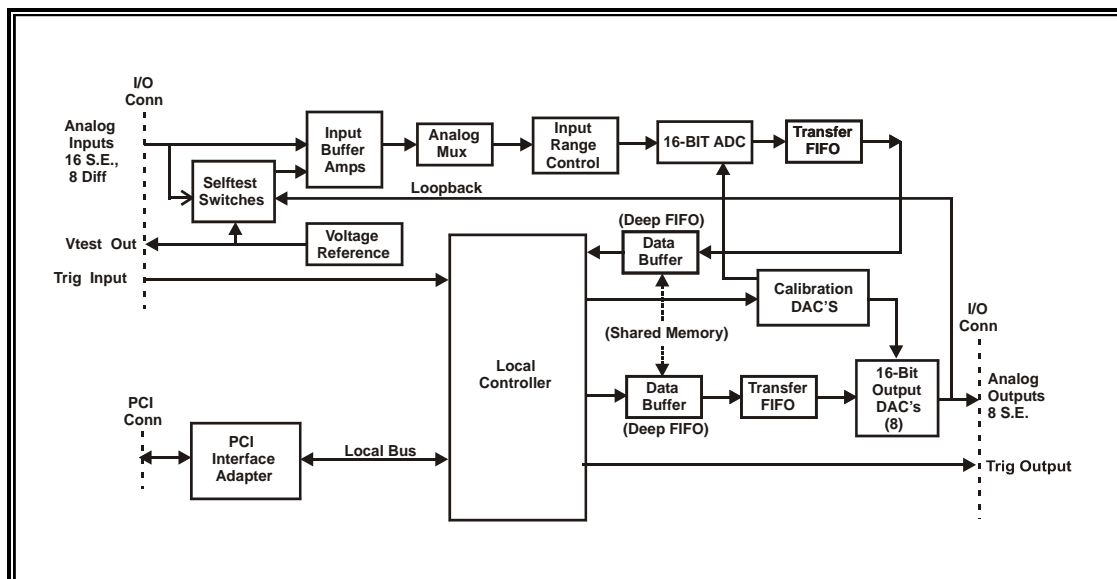

Figure 1. PMC-16AIO168; Functional Organization

This product is functionally compatible with the IEEE PCI local bus specification Revision 2.2, and the PC/104-Plus Specification, Version 1.1. System input/output connections are made through a standard 50-pin I/O connector. Power requirements consist of +5 VDC, in compliance with the PCI specification, and operation over the specified temperature range is achieved with conventional convection cooling.

# General Standards Corporation

## High Performance Bus Interface Solutions

### ELECTRICAL SPECIFICATIONS

At +25 °C, with specified operating voltages

#### ANALOG INPUT CHANNELS

##### □ Input Characteristics:

Configuration:	16 input lines, configurable as 16 single-ended or 8 differential channels
Voltage Ranges:	Software configurable as $\pm 10$ , $\pm 5$ or $\pm 2.5$ Volts
Input Impedance:	1.0 Megohms line-to-ground, 2.0 Megohms line-to-line, in parallel with 100Pfd. Independent of scan rate.
Bias Current:	80 nanoamps maximum
Noise:	2.0LSB-RMS typical
Common Mode Rejection:	60 dB typical, DC-60 Hz, differential input mode
Common Mode Range:	$\pm 10$ Volts; differential input configuration
Overvoltage Protection:	Standard: $\pm 30$ Volts with power applied; $\pm 15$ Volts with power removed

##### □ Transfer Characteristics:

Resolution:	16 Bits; 0.0015 percent of FSR		
Maximum Conversion Rate:	300K conversions per second, minimum		
Channels per scan:	1, 2, 4, 8, or 16 Channels per scan (16 channels available only in single-ended mode)		
Maximum Scan Rate:	150 KSPS in multiple-channel scanning mode. 300KSPS in single-channel mode. Scan rate equals the conversion rate divided by the number of channels per scan.		
Minimum Scan Rate:	460 scans per second, using a single internal rate generator; 0.007SPS using both generators. Zero, using a software sync flag or an externally supplied sync input.		
DC Accuracy: (Maximum composite error, referred to inputs)	<u>Range</u>	<u>Midscale Accuracy</u>	<u><math>\pm</math>Fullscale Accuracy</u>
	$\pm 10$ V	$\pm 3.2$ mV	$\pm 4.2$ mV
	$\pm 5$ V	$\pm 2.3$ mV	$\pm 2.8$ mV
	$\pm 2.5$ V	$\pm 1.6$ mV	$\pm 2.0$ mV
Crosstalk Rejection:	85dB, DC-10kHz		
Integral Nonlinearity:	$\pm 0.003$ percent of FSR, maximum		
Differential Nonlinearity:	$\pm 0.0015$ percent of FSR, maximum		

##### □ Analog Input Operating Modes and Controls

Analog Input Modes:	Single Scan:	Software or hardware trigger initiates a single scan of all active channels at the maximum conversion rate.
---------------------	--------------	---

# General Standards Corporation

## High Performance Bus Interface Solutions

Continuous Scan:	Inputs are scanned continuously at the selected scan rate.
Selftest:	Reference and loopback tests; autocalibration
Multiple-Channel:	2, 4, 8, 16 channels per scan (Includes 2-Channel mode).
Single-Channel:	Any single channel can be selected for digitizing at the maximum conversion rate.
Input Data Buffer:	32K-sample FIFO with 0000h-7FFEh adjustable threshold flag; DMA is supported

### ANALOG OUTPUT CHANNELS

#### □ Output Characteristics:

Configuration:	Eight single-ended output channels. (Ordering option)
Voltage Ranges:	Same as selected for analog inputs; $\pm 10$ , $\pm 5$ or $\pm 2.5$ Volts
Output Resistance:	1.0 Ohm, maximum
Output protection:	Withstands sustained short-circuit to output return
Load Current:	Zero to $\pm 5$ ma per individual channel; maximum total of 30ma total for all channels.
Load Capacitance:	Stable with zero to 2000 pF shunt capacitance
Noise:	2.0mV-RMS, 10Hz-100KHz typical
Glitch Impulse:	5 nV-Sec typical, $\pm 2.5$ V range

#### □ Transfer Characteristics:

Resolution:	16 Bits (0.0015 percent of FSR)												
Output Sample Rate:	Software adjustable from 400SPS to 300KSPS per channel; 0.006SPS to 300KSPS using both internal rate generators. DC to 300KSPS with hardware or software sync.												
DC Accuracy: (Maximum composite error, no-load)	<table><thead><tr><th>Range</th><th>Midscale Accuracy</th><th><math>\pm</math>Fullscale Accuracy</th></tr></thead><tbody><tr><td><math>\pm 10</math>V</td><td><math>\pm 2.7</math>mV</td><td><math>\pm 3.0</math>mV</td></tr><tr><td><math>\pm 5</math>V</td><td><math>\pm 1.9</math>mV</td><td><math>\pm 2.2</math>mV</td></tr><tr><td><math>\pm 2.5</math>V</td><td><math>\pm 1.3</math>mV</td><td><math>\pm 1.7</math>mV</td></tr></tbody></table>	Range	Midscale Accuracy	$\pm$ Fullscale Accuracy	$\pm 10$ V	$\pm 2.7$ mV	$\pm 3.0$ mV	$\pm 5$ V	$\pm 1.9$ mV	$\pm 2.2$ mV	$\pm 2.5$ V	$\pm 1.3$ mV	$\pm 1.7$ mV
Range	Midscale Accuracy	$\pm$ Fullscale Accuracy											
$\pm 10$ V	$\pm 2.7$ mV	$\pm 3.0$ mV											
$\pm 5$ V	$\pm 1.9$ mV	$\pm 2.2$ mV											
$\pm 2.5$ V	$\pm 1.3$ mV	$\pm 1.7$ mV											
Settling Time:	8 $\mu$ s to 1LSB, typical with 50-percent fullscale step												
Crosstalk Rejection:	85 dB minimum, DC-1000Hz												
Integral Nonlinearity:	$\pm 0.004$ percent of FSR, maximum												
Differential Nonlinearity:	$\pm 0.0015$ percent of FSR, maximum												

#### □ Analog Output Operating Modes and Controls

Clocking Modes:	Simultaneous Continuous Mode: Channel values in a designated channel group are stored in an intermediate buffer, and then are transferred to the output DAC's when an output clock occurs. The clock can be generated either by the internal rate generator, by a software flag, or by an external hardware trigger.
-----------------	--

# General Standards Corporation

## High Performance Bus Interface Solutions

**Simultaneous Burst Mode:** A single function (i.e.: burst) is initiated by a software or hardware sync. During a burst, channel values in a designated channel group are stored in a transfer buffer, and then are transferred to the output DAC's each time a clock pulse is generated by the internal rate generator. The burst terminates when a Burst End flag is encountered

**Channel-Sequential Modes:** Same as simultaneous modes, except each value in the data buffer is written immediately to the associated output DAC. The group-end flag is ignored in this mode.

Channel Assignment:	A 3-bit field in the output buffer assigns the associated data field to a specific output channel.
Group End:	A single bit in the output buffer indicates the last value in a channel group.
Burst End:	A single bit in the output buffer indicates the last value in an output burst sequence.
Output Data Buffer:	32K-sample FIFO with 0000h-7FFEh adjustable threshold flag; DMA is supported

### DIGITAL CONTROL OUTPUTS

Four digital output control lines provide TTL-level control of external devices. Output impedance is typically 1.0 Kohms.

### PCI INTERFACE

- ❑ **Compatibility:** Conforms to PCI Specification 2.2, with D32 read/write transactions.  
Supports "plug-n-play" initialization.  
Provides single multifunction interrupt.  
Supports DMA transfers as bus master.

### MECHANICAL AND ENVIRONMENTAL SPECIFICATIONS

- ❑ **Power Requirements**
  - +5VDC  $\pm$ 0.2 VDC at 1.4 Amps, maximum, 0.9 Amps typical
  - Power Dissipation: 7.0 Watts maximum; 4.5 Watts typical
- ❑ **Physical Characteristics (Overall, excluding spacers):**
  - Height: 23.3 mm (0.92 in)
  - Width: 94.0 mm (3.78 in)
  - Depth: 95.9 mm (3.70 in)
- ❑ **Environmental Specifications**
  - Ambient Temperature Range: Operating: 0 to +70 degrees Celsius \*  
Storage: -40 to +85 degrees Celsius  
\*Temperature of inlet cooling air.
  - Relative Humidity: Operating: 0 to 80%, non-condensing  
Storage: 0 to 95%, non-condensing
  - Altitude: Operation to 10,000 ft.
  - Cooling: Conventional convection cooling

# General Standards Corporation

## High Performance Bus Interface Solutions

### ORDERING INFORMATION

Specify the basic product model number followed by an option suffix "-A", as indicated below. For example, model number PC104P-16AIO168-8 describes a PMC module with eight output channels.

Basic Model Number	Form Factor
PMC-16AIO168	PMC
PCI-16AIO168 *	PCI, short length
cPCI-16AIO168 *	cPCI, 3U
PC104P-16AIO168	PC104-Plus (Native)

\* Module installed and tested on an adapter, with mechanical and functional equivalency. Contact factory for availability in native form factors.

Optional Parameter	Value	Specify Option As:
Number of Analog Outputs	No Output Channels	A = 0
	8 Output Channels	A = 8

# General Standards Corporation

## High Performance Bus Interface Solutions

### SYSTEM I/O CONNECTIONS

**Table 1. System I/O Connector Pin Functions**

PIN	FUNCTION	PIN	FUNCTION
1	INPUT RTN	26	ANA OUT 02
2	INPUT RTN	27	ANA OUT 01
3	ANA INP 00 HI	28	ANA OUT 00
4	ANA INP 00 LO	29	OUTPUT RTN
5	ANA INP 02 HI	30	OUTPUT RTN
6	ANA INP 02 LO	31	VTEST
7	ANA INP 04 HI	32	DIFF TRIG IN LO
8	ANA INP 04 LO	33	VTEST RETURN
9	ANA INP 06 HI	34	DIFF TRIG IN HI
10	ANA INP 06 LO	35	INPUT RTN
11	ANA INP 08 HI	36	INPUT RTN
12	ANA INP 08 LO	37	INPUT RTN
13	ANA INP 10 HI	38	DIFF TRIG OUT HI
14	ANA INP 10 LO	39	TTL TRIG OUT
15	ANA INP 12 HI	40	DIFF TRIG OUT LO
16	ANA INP 12 LO	41	OUTPUT RTN
17	ANA INP 14 HI	42	DIG OUT 00
18	ANA INP 14 LO	43	TTL TRIG IN
19	INPUT RTN	44	DIG OUT 01
20	INPUT RTN	45	OUTPUT RTN
21	ANA OUT 07	46	DIG OUT 02
22	ANA OUT 06	47	OUTPUT RTN
23	ANA OUT 05	48	DIG OUT 03
24	ANA OUT 04	49	OUTPUT RTN
25	ANA OUT 03	50	DIGITAL RTN

Note: Analog inputs are shown for the differential input mode. In single-ended mode, LO inputs become consecutive odd-numbered channels, beginning with ANA INP 01 replacing ANA INP 00 LO.

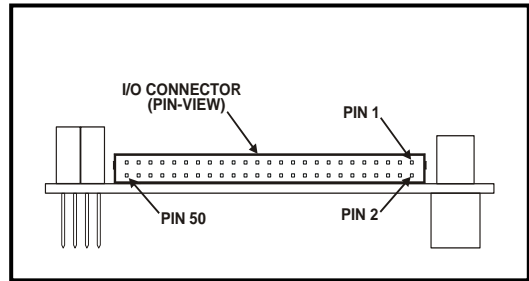

**Figure 2. System Input/Output Connector**

**System Mating Connector:**  
**Polarized 50-Pin socket connector:**  
**AMP #1-746288-0,**  
**with strain-relief #499252-4.**

**General Standards Corp.**

General Standards Corporation assumes no responsibility for the use of any circuits in this product. No circuit patent licenses are implied. Information included herein supersedes previously published specifications on this product and is subject to change without notice.