

ICS-8554B

Rugged 4-channel, Transformer-Coupled 105 MHz ADC PMC Module with DDCs, Xilinx FPGA and PCI 64/66 Interface

- 4 transformer-coupled ADC channels: 14-bits @ 105 MHz
- 2 Gray Chip GC4016 DDC ASICs
- 3M gate Xilinx Virtex-II FPGA
- 66 MHz, 64-bit PCI 2.2 DMA interface
- 2 MBytes FIFO buffer
- Pn4 user I/O supports LVTTTL or LVDS signaling levels
- Internal or external clock and trigger
- > 67 dB SNR and > 80 dB SFDR
- Multiple board synchronization
- Extensive application and technical support available
- VxWorks, Linux and Windows device drivers

ICS-8554B 4-channel ADC PMC module is a rugged version of the highly successful ICS-554, a four channel transformer-coupled ADC PMC module for Software Defined Radio (SDR) applications optimized to provide a high degree of functionality in a small, rugged package. By bundling substantial ADC, DDC, and FPGA resources in one PMC module, the ICS-8554B provides a powerful base band signal processing capability. Careful component selection and thermal management techniques allow this functionality to be maintained in demanding environments, supported by both air-cooled and conduction-cooled versions.

The board provides simultaneous sampling across all channels on one board or across multiple boards using either an internally or externally provided clock signal. Simultaneous triggering is also achieved across multiple boards using either an internal (software controlled) or an external trigger signal.

The two optional GC4016 Digital Down-converters (DDCs) provide a powerful base-banding and filtering function. A sync connector is provided to enable synchronization of the DDCs when changing NCO frequency and other parameters across channels on single or multiple boards using internal or external synchronization. Up to 8 simultaneous output bands can be provided. Simultaneous wide and narrow output bands are supported via the two decoupled FIFOs.

While providing substantial DSP resources in its 3M gate FPGA, which can be used to implement substantial bandwidth reduction at the outputs, the ICS-8554B still provides high bandwidth I/O for communication with host systems. The 64/66 PCI interface provides data rates in excess of 400 MBytes/sec (aggregate sustained rate), while the Pn4 User I/O port allows even higher data rates and elimination of interrupt latencies. Approximately 95% of the Virtex-II FPGA is available for user applications, and these are supported by means of a comprehensive Hardware Development Kit (HDK) for the Xilinx ISE Foundation development environment, enabling efficient development of new FPGA applications.

The ICS-8554B brings all the best attributes of the ICS-554 to the rugged application space, and improves on it by doubling the capacity of FIFO buffer onboard, and adding Built In Test (BIT) capability. The FIFO buffer consists of two decoupled FIFOs, thus allowing for applications in which simultaneous wide and narrow output bands are required.

Software

Software device driver support is available for VxWorks, Linux and Windows. A set of application examples in 'C' is provided with each driver. A LabVIEW application is provided under Windows only. An SCA-compliant driver can also be provided.

ICS-8554B Rugged 4-channel, Transformer-Coupled 105 MHz ADC PMC Module with DDCs, Xilinx FPGA and PCI 64/66 Interface

Specifications

Analog Input

- Four transformer-coupled analog inputs
- MMXX analog, clock, trigger, sync connectors
- 50 Ohm input impedance
- Full scale input +5.5 dBm into 50 Ohms (nom.)
- Max. safe input +24 dBm into 50 Ohms
- Input bandwidth 2 – 570 MHz (-3 dB)
- Maximum sample rate 105 MHz, 100 MHz when using DDCs
- Minimum sample rate 30 MHz
- Internal sample clock 100 MHz
- ADC resolution 14-bits
- Sampling on rising edge clock
- LVTTTL or sinewave ext. clock
- LVTTTL external trigger, sync signals
- ICS-8554B SINAD > 70dB SFDR > 80dB
- Harmonic distortion < -72 dBc
- Crosstalk < - 72 dB

General

- IEEE std. 1386.1-2001 compatible PCI Mezzanine Card
- ANSI/VITA 20-2001 conduction-cooled PMC
- VxWorks, Linux and Windows software drivers
- 11.8 Watts typical power dissipation (depends on user FPGA contents)
- MMXX coaxial connectors (signals, clock, trigger, sync)

Onboard Resources

- Xilinx Virtex-II FPGA (XC2V3000)
- 2 x GC4016 DDC (optional)
- 2 x 128K x 72 FIFO memories

I/O Specifications

- PCI 2.2 64-bit, 66 MHz PCI bus interface
- All 64 user programmable I/O via Pn4
- Connector routed directly to FPGA as differential pairs
- User definable signaling levels on Pn4 (LVDS, LVTTTL)

Environmental

- Five build levels available. Air and conduction cooled versions.
- Up to -40°C to +85°C operating temperature available
- 95% non-condensing humidity

Block Diagram

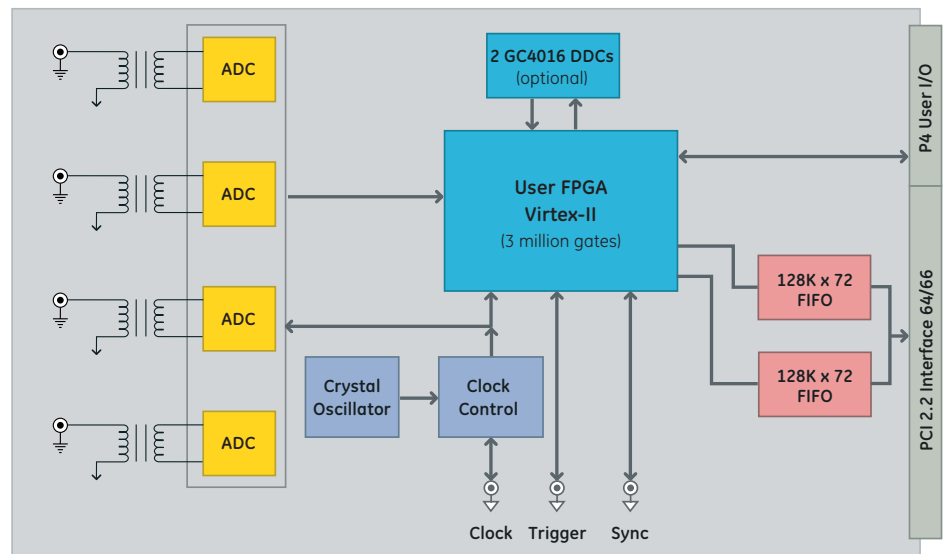

Ordering Information

ICS-8554B-x00	x: build level (1 – 5), with GC4016 DDCs
ICS-8554B-x01	x: build level (1 – 5), without GC4016 DDCs
DRV-8554-VXW	Software device driver for VxWorks operating system
DRV-8554-LX	Software device driver for Linux operating system
DRV-8554-WIN	Software device driver for Windows operating system
DRV-8554-SCA	SCA compliant driver
HDK-8554	Hardware Development Kit for FPGA development by user

About GE Fanuc Intelligent Platforms Embedded Systems

GE Fanuc Intelligent Platforms is a leading global provider of embedded computing solutions for a wide range of industries and applications. Our comprehensive product offering includes many types of I/O, single board computers, high performance signal processors, fully integrated, rugged systems including flat panel displays, plus high speed networking and communications products. The company is headquartered in the U.S. and has design, manufacturing and support offices throughout the world. Whether you're looking for one of our standard products or a fully custom solution, GE Fanuc Intelligent Platforms has the breadth, experience and 24/7 support to deliver what you need. For more information, visit www.gefanuc.com.

GE Fanuc Intelligent Platforms Information Centers

Americas:
1 800 368 2738 or 1 703 263 1483

Asia Pacific:
+81 3 5544 3973

Europe, Middle East and Africa:
Germany: +49 821 5034-0
UK: +44 1327 359444

Additional Resources

For more information, please visit the GE Fanuc Intelligent Platforms web site at:

www.gefanuc.com

