

VMIVME-3113A Specifications



Scanning 12-bit Analog-to-Digital Converter Board with Built-in-Test

Features:

- 64 differential or single-ended inputs
 - Powers up in autoscanning mode — no software initialization required
 - Continually digitizes input channels and stores the results in a dedicated channel dual-port register (autoscanning mode)
 - Jumper-selectable scanning of 2 to 64 channels
 - Supports real-time and off-line Built-in-Test
 - Five operating modes plus test mode
 - Autoscanning mode (gain=1)
 - Random poll mode
 - Random interrupt mode
 - Scanning poll mode
 - Scanning interrupt mode
 - VMEbus interrupts may be programmed to interrupt upon completion of a single A/D conversion or upon completion of a 2- through 64-channel scan
 - User-programmable interval timer supports scanning of all channels at periodic intervals
- Jumper-programmable gain 1, 10, 100, 200, and 500
 - Selectable A/D ranges of 0 to +10V , ±5V, and ±10V
 - Low-level and high-level inputs: ±10mV to ±10V
 - Optional low pass filter (the VMIVME-3113A has improved high-frequency rejection characteristics)
 - Overvoltage protected inputs
 - $5 \times 10^6 \Omega$ input impedance
 - 33 kHz conversion rate
 - Selectable output code: binary, offset binary, two's complement with sign extension
 - Applications
 - Factory automation and instrumentation
 - Process control
 - Laboratory instrumentation
 - Machine monitoring
 - Data acquisition



Ordering Options						
July 7, 2006 800-103113-000 C	A	B	C	D	E	F
VMIVME-3113A	-	0	0	0	0	

A = Input Filter Options
 0 = No Filter
 1 = 40 Hz (3 dB Cutoff Frequency)
BCDE = 0 (Options reserved for future use)
F = Conformal Coating
 0 = Standard VME front panel without conformal coating
 1 = Reserved
 2 = Standard VME front panel with conformal coating

Connector Data		
Style	Recommended Connecting Component	P3 and P4 I/O Connectors
64-pin IDC	Mating Connector (64-pin) Strain Relief (for 64-pin Connectors)	Panduit 120-964-435E Panduit 100-000-032
96-pin Discrete Wire	Mating Connector (96-pin Discrete) Female Crimp Contacts (96-pin Discrete)	AMP 925486-1 AMP 530151-6*
	Connector Housing (For 96-pin Connectors)	Hurting 09 03 096 0501 ERNI 913.031
96-pin IDC	Mating Connector (96-pin Mass Terminated)	ERNI 913.049
	0.033-inch Ribbon Cable (96-pin Mass Terminated)	Erni 913.049
	Strain Relief Insert (0.033-inch Ribbon Cable)	Harting 09 02 000 9912
	Connector Housing (For 96-pin Connectors)	Harting 09 03 096 0501

PC Board I/O Connector Part Number Panduit 101-096-033A

*AMP crimp tool part number 90301-2.

For Ordering Information, Call: 1-800-322-3616 or 1-256-880-0444 • FAX (256) 882-0859 Email: info.embeddedsystems@gefanuc.com Web Address: www.gefanuc.com/embedded Copyright © 2006 by GE Fanuc Embedded Systems Specifications subject to change without notice.

Functional Characteristics

Introduction: This product is designed to support 64 channels of differential or single-ended wide range ($\pm 10\text{mV}$ to $\pm 10\text{V}$) analog inputs.

The board supports the following operating modes which are described below:

- Autoscanning
- Random Polling
- Random Interrupt
- Scanning Poll
- Scanning Interrupt
- Autoscanning with BIT

A 64-word dual-port provides storage for a continuous scan of all channels. The scanning modes are executed automatically at powerup, system reset, or are entered under program control. The dual-port registers allow VMEbus access at any time to read the latest stored data.

A jumper-selectable, Programmable Gain Amplifier supports gain ranges of 1, 10, 100, 200, and 500. A/D conversion time is $15\mu\text{s}$. A wide variety of low pass filters are supported.

A functional block diagram is provided in Figure 1 in on page 5 of this specification.

Operating Modes

Autoscanning Mode: The mode is executed by a powerup system reset or program selection. All channels are continuously scanned and the digitized data is stored in 64, 16-bit dual-port registers. No other programming is required to start the A/D conversion process. The user has only to read the digitized data from the dual-port register of the desired channel. This mode is for gains of 1 only and for a minimum of 16 connected channels.

Random Polling Mode: This mode requires the controlling program to generate a single conversion. End-of-conversion is determined by polling an end-of-conversion status bit.

Random Interrupt Mode: This is the same as Random Poll Mode except end-of-conversion generates an interrupt to the CPU board.

Scanning Poll Mode: This is a scanning mode which executes a single scan of all channels. An end-of-scan control bit is polled to determine when the scan is completed.

Scanning Interrupt Mode: This is a scanning mode which executes a single scan of all channels and generates an end-of-scan interrupt when the scan is completed.

Autoscanning Bit Mode: All channels continuously scanned with channel 0 muxing in one of three precision reference voltages. The voltages are 4.980, 0.4928, and 0.009915V.

Programmable Interval Timer: A triple, 16-bit timer (may be cascaded to 48 bits) is programmable to generate a periodic trigger to start an A/D scan.

External Trigger: A user-connected signal may be used to start a scan.

Programmable Gain Amplifier: A jumper Programmable Gain Amplifier supports conversions of low-level inputs (from $\pm 10\text{mV}$ to $\pm 10\text{V}$ full scale).

End-of-Conversion/Scan Interrupts: The Scanning Interrupt Mode and the Random Scanning Mode generate an end-of-conversion or end-of-scan interrupt, respectively. All VMEbus interrupt levels 1 to 7 are supported through a user-programmable on-board Bus Interrupter Module (BIM).

Compatibility: The ADC board is a standard double height printed circuit board which is compatible with the VMEbus specification (Rev. C.1).

Board Address: The physical address for the board may be selected by on-board jumpers. VMEbus address lines A08 through A15 are decoded for board selection. The board occupies 256 bytes in the short I/O address space.

Address Modifier: Address modifier bits are jumper-selected and decoded to support either nonprivileged short I/O, supervisory short I/O, or both. The board is factory configured for supervisory short I/O.

Analog Input Format: Analog inputs are digitized and stored in 64 dual-port registers as a 12-bit digital value (D11 to D00) which may be read by the user. Selectable data codes are binary, offset binary, and two's complement. The sign is extended to the upper four bits (D12, D13, D14, and D15).

System Reset: System reset automatically places the board in the Autoscanning Mode.

Front Panel Diagnostic LED: A software-controlled LED may be extinguished upon successful completion of diagnostics. The LED is illuminated by system reset.

Electrical Specifications

(Typical at +25°C and rated power supplies unless otherwise stated.)

Input Characteristics

Number of Input Channels: 64 differential or 64 single-ended

Full-Scale A/D Input Ranges: ±5V, ±10V, and 0 to +10V

Amplifier Gain Ranges: 1, 10, 100, 200, and 500
Jumper-programmable

Full-Scale Input Range: ±10mV to ±10V

Input Impedance: 5 × 10⁶Ω differential. 2 × 10⁶Ω single-ended

Common-Mode Voltage (Maximum):
±11V ($V_{CM} + V_{diff}/2$)*gain

Input Overvoltage Protection: ±40V, maximum

Optional Single-Pole Analog Input Filter: -3 dB at 40 Hz

Transfer Characteristics

Resolution: 12 bits

Analog Input Acquisition Time:

G = 1, 10, 100, 200	15μs
G = 500	28μs

A/D Conversion Time: 15μs

A/D Conversion Rate (Maximum):

G = 1, 10, 100, 200	33 kHz
G = 500	23 kHz

Channel Conversion Rate (Maximum):

G = 1, 10, 100, 200	33 kHz ÷ number of channels scanned
G = 500	23 kHz ÷ number of channels scanned

Accuracy

Instrumentation Amp Nonlinearity, DC:

G = 1	±0.001 percent FSR
G = 10	±0.002 percent FSR
G = 100	±0.004 percent FSR
G = 200	±0.006 percent FSR
G = 500	±0.01 percent FSR

System Accuracy (Including Linearity Error):

G = 1	0.035 percent FSR
G = 500	0.075 percent FSR

Stability (Over Temperature)

Instrumentation Amp Drift:

±(2.0 + 20/G) μV/°C

System Accuracy Drift:

G = 1	5 PPM/°C
G = 500	50 PPM/°C

Bus Interface

Compatibility: VMEbus A16: D16

Interrupt: IRQ1 through IRQ7

Interrupter Release: ROAK (Release-on-Acknowledge)

Physical/Environmental Specifications

Dimensions: Standard VME double height board
160 × 233.5mm

Power Requirements: +5VDC (±5 percent) at 2.5A maximum

Temperature: Operating: 0 to 55° C
Storage: -25 to +85° C

Altitude:

Operating: 0 – 10,000 ft (3,000m)
Storage: 0 – 40,000 ft (12,000m)

Humidity:

Operating: relative humidity 20% to 80%, noncondensing

Cooling: Forced air convection

Front Panel Analog Input Connector: Board connector (P3 and P4) - 96-pin DIN connector, center row grounded. Accepts 64- and 96-pin mating connectors (see mating connector data on page 2).

Trademarks

All registered trademarks are the property of their respective owners.

APPLICATION AND CONFIGURATION GUIDES — The following Application and Configuration Guides are available from GE Fanuc Embedded Systems to assist the user in the selection, specification and implementation of systems based on GE Fanuc Embedded Systems' products.

Title	Document No.
Digital Input Board Application Guide	825-000000-000
VMEbus Change-of-State Boards (COSMODULES™) Application Guide	825-000000-002
Digital I/O Products with Built-in-Test Product Line Description	825-000000-003
Synchro/Resolver (Built-in-Test) Subsystem Configuration Guide	825-000000-004
Analog I/O Products (with Built-in-Test) Configuration Guide	825-000000-005
Connector and I/O Cable Application Guide	825-000000-006
Data Acquisition Noise Reduction in Industrial Environments Application Guide	825-000000-026
IOWorks Base Package Application Guide	825-000000-027
IOWorks Systems Application Guide	825-000000-028

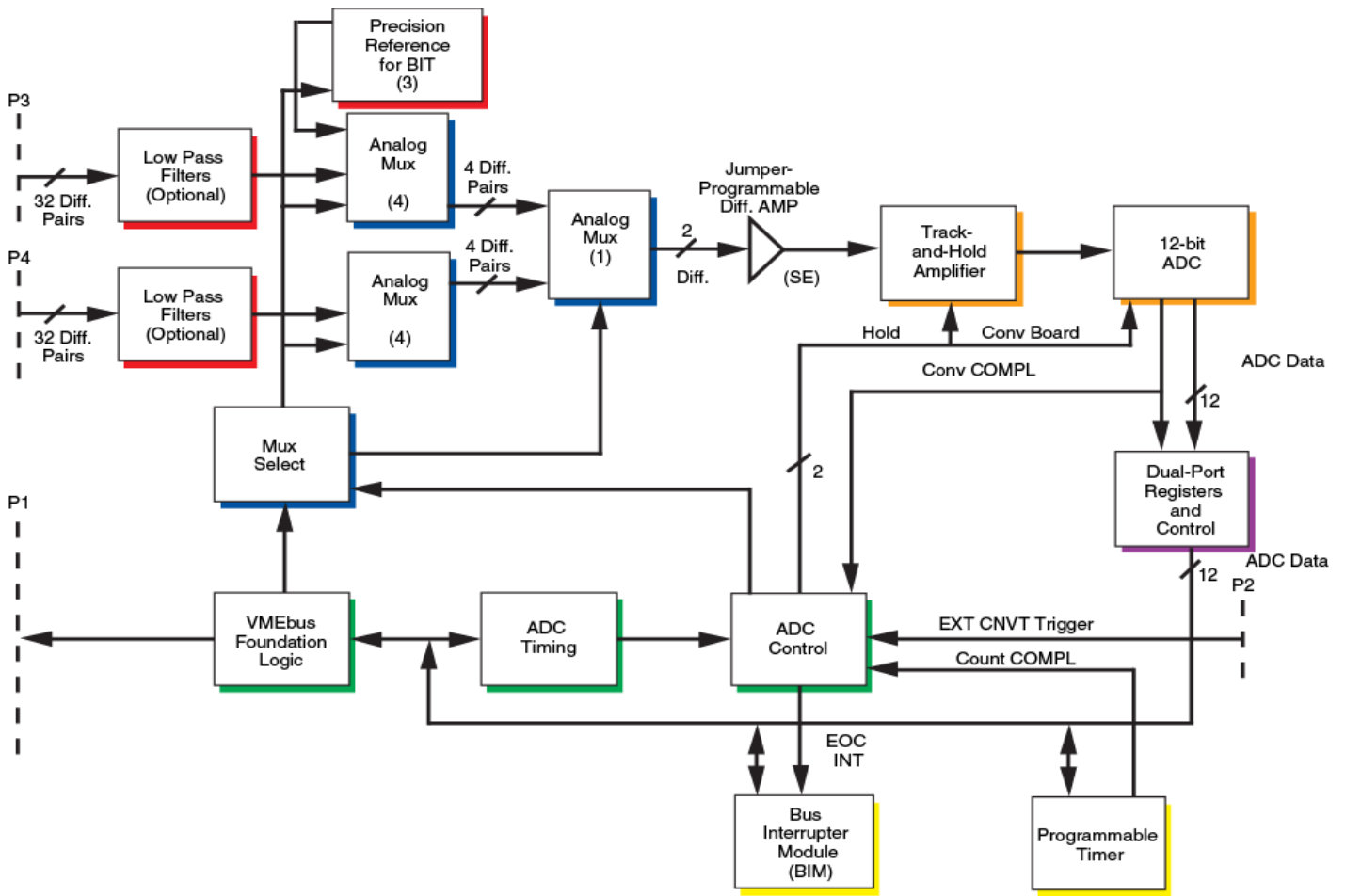

Figure 1. VMIVME-3113A Functional Block Diagram



GE Fanuc Embedded Systems Information Centers

Americas:
 Huntsville, AL 1 800 322-3616
 1 (256) 880-0444
 Camarillo, CA 1 (805) 987-9300
 Greenville, SC 1 (864) 627-8800
 Richardson, TX 1 (972) 671-1972

Europe, Middle East and Africa:
 Edinburgh, UK 44 (131) 561-3520
 Paris, France 33 (1) 4324 6007

Additional Resources

For more information, please visit the GE Fanuc Embedded Systems web site at:
www.gefanuc.com/embedded