

V5D

High Performance 6U VMEbus Embedded Computer

Features

- Pentium® M processor LV 738 - 1.4 GHz and 2 Mbyte on-chip L2 cache
- 400 MHz Front Side Bus
- 855GME Graphics and Memory Controller Hub
- 6300ESB I/O Controller Hub
- DDR SDRAM: 512 Mbyte or 1 Gbyte with ECC on 266 MHz Memory Bus
- SVGA video - up to 1600 x 1200
- Ultra-DMA100 interface at the backplane
- Optional on-board Type I CompactFlash
- PCI Expansion interface for installing a PMC carrier
- Two Gigabit Ethernet RJ-45 ports
- Serial I/O: COM1—RS-232, COM2—configurable (RS-232/422/485)
- Optional Ultra 16-bit SCSI interface
- 32 Kbyte NVRAM
- PS/2 keyboard/mouse port
- Floppy drive interface
- Two USB 2.0 ports
- IEEE 1284 parallel port
- Temperature sensor
- Real-time clock with on-board battery

Benefits

V5D is the next generation in the V5x family of 6U VMEbus Single Board Computers offering an Intel® Pentium® M processor LV 738 that features 90nm technology with processing speed of 1.4 GHz. The Pentium M 738 includes on-chip 32 Kbyte L1 instruction and data caches and 2 Mbyte of L2 cache.

The V5D couples the Pentium M LV 738 with the Intel® 855GME Chipset which includes the 855GME Graphics and Memory Controller Hub (GMCH) and the 6300ESB I/O Controller Hub (ICH). The 855GME GMCH provides a 400 MHz Front Side Bus interface and a memory controller with a 64-bit 266 MHz memory interface that services up to 1 Gbyte of DDR SDRAM. It also includes an internal SVGA video controller with 2D and 3D graphics engines and a 350 MHz 24-bit RAMDAC that can drive an analog CRT monitor at resolutions up to 1600 x 1200.

The 6300ESB I/O Controller Hub provides a 400 MHz System Bus interface and two PCI bus interfaces as well as a USB 2.0 Controller and two Ultra-DMA100 interfaces to the backplane or one IDE backplane interface with an optional on-board Type I CompactFlash card (replaces FDOC which was used on prior generation of V5X boards).

The V5D features high-speed LAN connectivity with two Gigabit Ethernet ports on the front panel, and an Ultra 16-bit SCSI interface and floppy drive interface at the backplane.

The V5D includes a PC87417 LPC Server I/O, which provides two serial I/O ports, a parallel port, and a PS/2-style keyboard/mouse port to the front panel. COM1 is configured for RS-232 operations while COM2 is user-configurable to RS-232/422/485.

The V5D implements the Tundra® Universe IID VMEbus Bridge for handling data transfers to and from the VMEbus backplane. The Universe IID supports VITA 1.1 VME64x bus transfers and supports master or slave operation.

V5D High Performance VMEbus Embedded Computer

Specifications

Processor

- Intel® Pentium® M processor LV 738 with core processing speed of 1.4 GHz
- High performance, low power consumption, Intel Architecture (IA)
- 32 Kbyte L1 instruction and data caches
- 2 Mbyte L2 on-chip cache
- 400 MHz Front Side Bus interface through the 855GME GMCH

Memory – DDR SDRAM

- 512 Mbyte or 1 Gbyte of soldered DDR266 SDRAM (PC2100)
- 64-bit 266 MHz Memory Bus (72-bit with ECC)

Flash ROM

- 1 Mbyte Firmware Hub (FWH) for BIOS code
- Multiple levels of write-protection

Video

- Integrated SVGA video controller through 855GME Graphics and Memory Controller Hub
- Supports render core and display core frequencies up to 200 MHz
- 2D and 3D graphics engines
- 350 MHz 24-bit RAMDAC to drive analog CRT monitor at 1600 x 1200 pixel resolution

PCI Bus

- Dual PCI interface through the 6300ESB ICH
- PCI Bus 2: 32-bit, 33 MHz—VME Backplane Bridge, Ultra- SCSI Controller, PCI Expansion site
- PCI Bus 1: 64-bit, 66 MHz—dedicated to Ethernet Controller

PCI Bus Expansion

- JX1/JX2 Mictor connectors on 32-bit/33MHz PCI Bus 0
- Up to three PMC sites on PMC carrier cards attached to expansion site (TPMCC)

VME Backplane Bridge

- Universe IID VMEbus Bridge
- VITA 1.1 VME64x Bus standard interface
- Master or slave operation
- Full system controller functionality

Ethernet

- Intel® 82546GB Dual Port Gigabit Ethernet Controller with integrated MAC and PHY
- Two RJ-45 connectors on front panel

Serial Ports

- COM1: full-duplex RS-232 interface
- COM2: configurable to full-duplex RS-232, async. RS-422, or half-duplex RS-485 interface

EIDE Interface

- Two Ultra-DMA33/66/100 Bus interfaces at backplane (supports two external IDE drives) or one IDE backplane interface with optional on-board Type I CompactFlash module

SCSI Interface

- Ultra SCSI Interface (optional)
- 16-bit interface at backplane

Floppy Drive Interface

- Floppy drive interface at backplane through PC87417 LPC Server I/O

USB I/O

- Two 2.0-compatible USB ports (front and rear I/O)
- Integrated USB Controller through the 6300ESB ICH

Parallel Port

- IEEE 1284 Parallel port at the front panel from the PC87417 LPC Server I/O

Keyboard/Mouse Port

- PS/2-style keyboard/mouse port at the front panel from the PC87417 LPC Server I/O

V5D High Performance VMEbus Embedded Computer

NVRAM

- 32 Kbyte NVRAM

RTC

- Real-time clock feature for timekeeping functions
- On-board Lithium Battery backup

Temperature Sensor

- CPU die and ambient temperature
- Software readable from -55 °C to +125 °C

Power Requirements

- +5 V, (±12V provided to PCI expansion only)

Power Consumption

- Peak:* 30 W
- Max. sustained:* 26 W
- Idle:** 23 W
- Inrush: 32 W
- VBATT: < 0.1 mW

* Calculated values

** Measured with Windows XP active

Mechanical

- VITA 1.1 VME64x Bus compliant (3-row or 5-row backplane connectors)
- VITA 1/IEEE 1101.1 air-cooled 6U form factor
- 233 x 160 x 20 mm
- Weight - 1.25 lbs

MTBF

- Calculations are available in accordance with MIL-HDBK-217. Please contact GE Fanuc Intelligent Platforms for latest values.

Safety

- Designed to meet standard UL1950/60950

Emissions

- Designed to meet FCC Part15, Class A certification

Humidity (non-condensing)

- Operating: 5-95% @ 40 °C
- Storage: 5-95% @ 40 °C

Altitude

- Operating: 4.5 km (15,000 ft.)
- Storage: 6 km (20,000 ft.)

Shock

- C-Style: 20 g / 11 ms, 3 axes, up & down, 3 hits/direction

Vibration

- C-Style: 0.04 g² /Hz @ 5 to 100 Hz, 60 minutes each axis

Temperature

- Range: Standard
- Operating: 0 °C to +70 °C
- Storage: -40 °C to +85 °C

Input/Output

I/O	Front Panel	P2	On-board	VME-TB51
COM1: RS-232	DB-9			
COM2: RS-232/422/485	DB-9			
CompactFlash			2x 25	
LPT	Mini-DB25			
Ethernet (ET H1, ET H2)	RJ-45			
PS/2 Keyboard/mouse	Mini-DIN (6-pin)			
PCI Expansion			2x (2 x 40)	
PIDE		X		2x 20
SIDE		X		2x 20
SVGA	HD-15			
USB0	Type A			
USB1		X		Type A*
SCSI (16-bit)		X		68*
SCSI (8-bit)		X		DB50/2x 25
Floppy Drive Interface		X		2x 17

* Rear panel connectors, DB25 - 8-bit SCSI, Type A - USB

V5D High Performance VMEbus Embedded Computer

Block Diagram

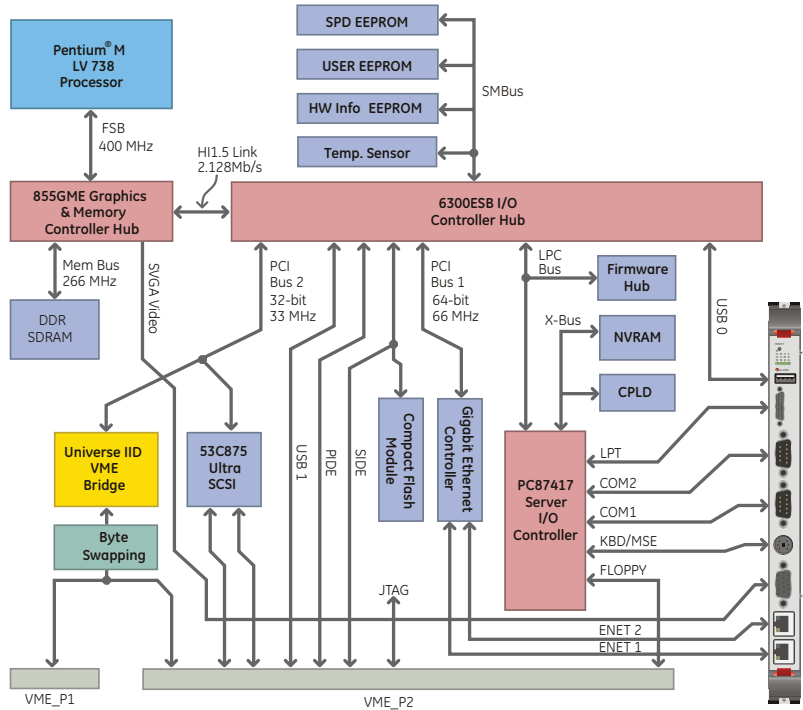

Ordering Information

V5D12101	1.4 GHz, 1 GB, SDRAM, SCSI, RoHs
V5D12001	1.4 GHz, 1 GB, SDRAM, RoHs

Hardware Accessories

VME-TB51	6U Transition Module
TPMCC	Triple PMC Mezzanine Card Carrier
VME-6260	Hard/Floppy Drive Module
CA9524	24" 9 pin Micro D serial Cable assembly

Operating Systems

GE Fanuc Intelligent Platforms supports various operating systems. Please contact us for current offerings. For detailed information and further options, contact GE Fanuc Intelligent Platforms.

About GE Fanuc Intelligent Platforms

GE Fanuc Intelligent Platforms is a leading global provider of embedded computing solutions for a wide range of industries and applications. Our comprehensive product offering includes many types of I/O, single board computers, high performance signal processors, fully integrated, rugged systems including flat panel displays, plus high speed networking and communications products. The company is headquartered in the U.S. and has design, manufacturing and support offices throughout the world. Whether you're looking for one of our standard products or a fully custom solution, GE Fanuc Intelligent Platforms has the breadth, experience and 24/7 support to deliver what you need. For more information, visit www.gefanuc.com.

GE Fanuc Intelligent Platforms Information Centers

Americas:
1 800 322 3616 or 1 256 880 0444

Asia Pacific:
+81 3 5544 3973

EMEA:
Germany: +49 821 5034-0
UK: +44 1327 359444

Additional Resources

For more information, please visit the GE Fanuc Intelligent Platforms web site at:

www.gefanuc.com

