

Telum™ 1001-O3

High Performance OC-3 ATM AdvancedMC™ with Traffic Management and Support for Automatic Protection Switching

Features

Performance

- OC-3 bps full duplex line speed
- PCI Express interface; PCI-e Rev 1.0 compliant; support for a full duplex operation
- 4 MB local memory supporting 16,000 VCCs
- Optional APS
- Segmentation and reassembly of AAL0, AAL3/4, and AAL5 cells
- Traffic management supported: ABR, CBR, UBR, and VBR
- Single or APS port version
- Hot swap compliant
- Supports ATM Forum UNI 3.1 and TM 4.0

Management

- IPMI; on-board microcontroller-based subsystem

AMC Compliance

- AMC.0 compliant, extended height module
- AMC.1 PCI Express Serial Fabric Interface with common option
- Hot swap capable

Software Support

- Carrier Grade Linux
- API
- Comprehensive Driver Development Kit

Applications

- Edge & core switches/ routers
- Wireless base stations
- DSLAM
- Server platforms
- Test & measurement

Product Reliability

- High MTBF
- Technical support for OEM customers and resellers

The Telum™ 1001-O3 is a high performance, single wide, full height, AMC.1 compliant ATM adapter featuring a front I/O full duplex OC-3 interface. The Telum 1001-O3 uses the PCI Express (PCIe) Bus to communicate with the host processor on an Advanced Telecom Computing Architecture (ATCA) system. The Telum 1001-O3 complies with ATM Forum UNI 3.1 and TM 4.0 and is based on an advanced ATM Segmentation and Reassembly (SAR) Controller designed to optimize the PCIe interface. The SAR segments and reassembles AAL0, AAL3/4, and AAL5 cells. The Telum 1001-O3 supports one full duplex OC-3 port for protocol data unit sizes as small as two cells. An optional Automatic Protection Switching (APS) port is available.

Traffic Management

The traffic management co-processor within the SAR supports Constant Bit Rate (CBR), Variable Bit Rate (VBR), Unspecific Bit Rate (UBR), Available Bit Rate (ABR), Guaranteed Frame Rate (GFR), and Generic Flow Control (GFC). To maximize line utilization, the xBR traffic management block automatically schedules each VCC according to user assigned parameters.

Intelligent Platform Management Interface (IPMI) & Hot Swap Compliance

An Intelligent Platform Management Interface (IPMI) subsystem initializes board level parameters, monitors board voltage and temperature conditions, maintains system status, and manages hot swap operation. A microcontroller is used as the IPMI intelligence and connects to the ATCA System Management bus and the local PCIe Bridge device. The Telum 1001-O3 is hot swappable and field-replaceable in accordance with AMC.0.

Automatic Protection Switching

APS initiation time requirements are supported as required in Bellcore Standard GR-253-CORE. If a network failure condition is detected, this network port can be shut down and network termination switched to the second port. This APS function can be performed automatically or under host control to ensure high availability of services.

Software

To simplify system integration, the Telum 1001-O3 employs a comprehensive set of software drivers that are compatible with Carrier Grade Linux operating systems. Additional software includes: a user friendly Application Programmers Interface (API), and a Driver Development Kit (DDK) that provides a common development environment for multiple interfaces.



Telum 1001-03 High Performance OC-3 ATM AdvancedMC

Specifications

Bus Interfacet

- PCI Express
- AMC.1 compliant

Board Resources

- CN8236 OC-3 SAR
- CX28250 PHY, 2 PHYs for optional APS
- PLX 8111 Dual PCI-to-PCI Express Bridge
- Automatic Protection Switching for port redundancy
- 8051 based IPMI subsystem
- OC-3 SFF optical transceiver; single & multi-mode support

Power Requirements

- Typical
- +3.3V @ 3.0A (w/APS Port)
- +1.5V @ 3.0A (w/APS Port)

Form Factor

- AMC.1 compliant

Environmental

- Operating temperature: 0°C to +55°C
- Storage temperature: -45°C to +85°C
- Humidity (R.H. non- condensing): Min. 20% Max. 95%

Regulatory Compliance

- FCC Part 15 Class "A"
- UL60950-1
- CSA22.1 No. 60950-1
- CE Mark
 - EN55022
 - EN55024
 - EN60950-1

Block Diagram

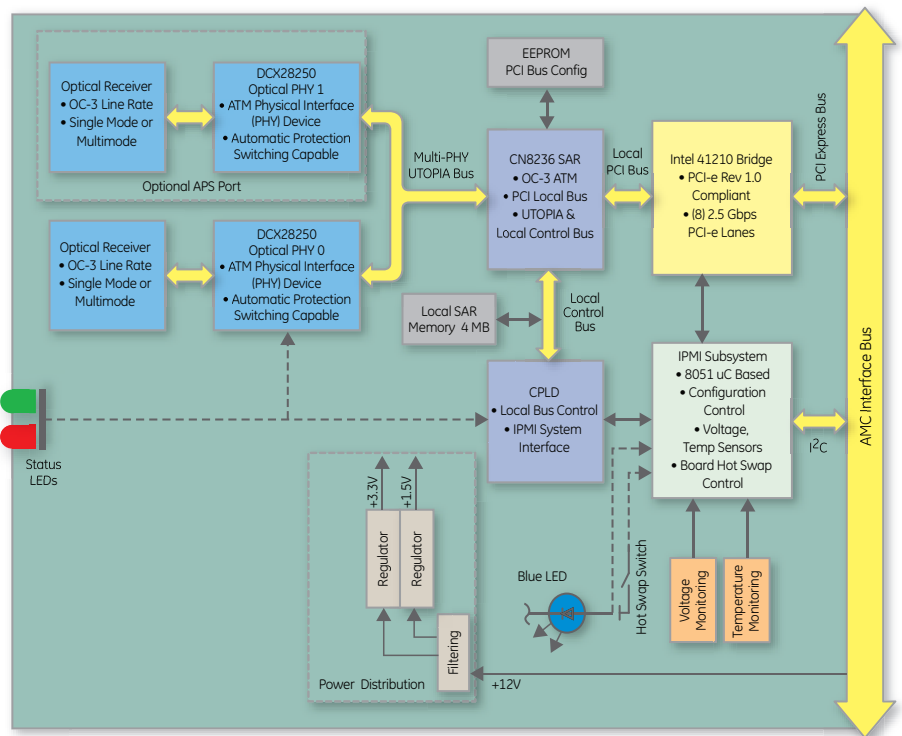

Ordering Information

22001-101

Telum 1001-03M1 4MB (single port, multi-mode optics, SFP connector)

22001-102

Telum 1001-03M2 4MB (APS port, multi-mode optics, SFP connectors)

22001-103

Telum 1001-03S1 4MB (single port, single mode optics, SFP connector)

22001-104

Telum 1001-03S2 4 MB (APS port, single mode optics, SFP connectors)

About GE Fanuc Embedded Systems

GE Fanuc Embedded Systems is a leading global provider of embedded computing solutions for a wide range of industries and applications. Our comprehensive product offering includes many types of I/O, single board computers, high performance signal processors, fully integrated, rugged systems including flat panel displays, plus high speed networking and communications products. The company is headquartered in the U.S. and has design, manufacturing and support offices throughout the world. Whether you're looking for one of our standard products or a fully custom solution, GE Fanuc Embedded Systems has the breadth, experience and 24/7 support to deliver what you need. For more information, visit www.gefanucembedded.com.

GE Fanuc Embedded Systems Information Centers

Americas:

1 800 322 3616 or 1 256 880 0444

Asia Pacific:

86 10 6561 1561

Europe, Middle East and Africa:

+49 921 5034-0

©2007 GE Fanuc Embedded Systems. All rights reserved.
All other brands or names are property of their respective holders.
Specifications are subject to change without notice.

Additional Resources

For more information, please visit the GE Fanuc Embedded Systems web site at:

www.gefanucembedded.com

