

SBC320

3U VPX Single Board Computer

Features

- Intel® Core™ 2 Duo (1.5GHz L7400)
- Intel 3100 chipset
- DDR2 up to 2 GB
- Up to 1 GB user flash memory
- One PMC site
- PCI-X 133 Mhz
- I/O to P2
- Two 4-lane PCI Express ports to the backplane for connection to fabric
- Two USB 2.0 ports
- SATA 150 Port
- Two 10/100/1000BaseT ports
- Two UART ports (RS232)
- Air and conduction cooled versions
- 3U VPX form factor (0.8" pitch)
- Optional covers for 2-level maintenance (0.85" pitch)
- Comprehensive Deployed Test software
- Comprehensive OS support

The VPXcel3 SBC320 is the latest member of GE Fanuc Intelligent Platforms' growing portfolio of 3U VPX Single Board Computers targeted at the most demanding applications in embedded computing.

The VPXcel3 product family offers Intel Architecture SBCs in 3U VPX form factor and is designed to offer long term program support by maintaining a common hardware and software interface between family members, easing customer's integration of future family members.

The SBC320's processor node features Intel's very latest processor and chipset designed specifically for small form factor cards, delivering impressive system level performance per watt. The Intel Core 2 Duo Processor is Intel's second generation dual core processor. This processor is designed to deliver low power and efficient breakthrough performance and responsiveness for demanding embedded market applications. The performance of this processor enables it to concurrently execute multiple threads and run multiple intense applications simultaneously.

The VPX form factor allows for high speed PCI Express connections to other cards in the system. SBC320 supports two 4-lane PCI Express ports across the backplane, providing high speed data communication to other single board computers, graphics cards, PCI Express switches and PMC/XMC carrier cards in order to build complex systems.

The SBC320 provides a number of high speed interfaces for off-board communication, including two Gigabit Ethernet ports, two USB 2.0 ports and a Serial ATA disk interface. In addition, there is support for legacy interfaces, including two RS232 ports, and four general purpose I/O lines.

The SBC320 utilizes state-of-the-art cooling technology to allow a PMC to be fitted without compromising processor node performance.

Available in five air and conduction cooled build levels the SBC320 is fully supported by comprehensive Deployed Test Software (BIT and BCS) and OS support for VxWorks®, Windows® and Linux®.



SBC320 3U VPX Single Board Computer

Specifications

Processor

- L7400 1.5 GHz Low Voltage Processor
- 4 MB L2 full speed on-chip cache

DDR2 SDRAM

- 2 GB DDR2 SDRAM
- ECC single bit correction
- ECC detection
- 72-bit memory bus up to 667 Mhz

Flash Memory

- 512 KB boot flash memory
- Up to 1 GB user flash memory
- Write-protection options

Fabric Interface

- Two 4-lane PCI Express ports (2.5 GHz)

Gigabit Ethernet

- Two 10/100/1000 Base-T ports

Serial I/O

- Two UART ports (RS232)

General-Purpose I/O

- Four general-purpose I/O (GPIO) lines each capable of generating an interrupt

USB

- Two USB 2.0 ports from Intel 3100

PMC Extension Slots

- One IEEE 1386/1386.1-2001 compatible extension slots
- PMC – up to 64-bit /133 MHz PCI-X
- 64 I/O pins to P2

NVRAM/Real-Time Clock/Watchdog/ETI

- 128 KB non-volatile RAM with Autostore
- Real-time clock in Intel 3100
- Watchdog timer in Intel 3100
- Elapsed Time Indicator (records cycles and on-time)

Temperature Sensors

- CPU die and ambient temperature

Power Requirements

- +5 V and 3.3 V – required
- ±12 V – only if required by mounted PMC module

Block Diagram

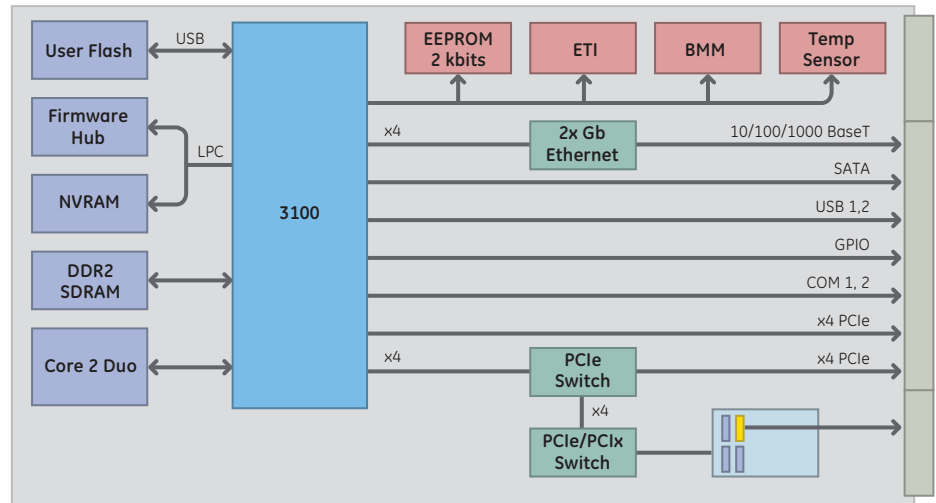

Environmental

	Level 1	Level 2	Level 3	Level 4	Level 5
Cooling Method	Convection	Convection	Convection	Conduction	Conduction
Conformal Coating	Optional	Standard	Standard	Standard	Standard
High/Low Temp	0 to 55°C	-20 to +65°C	-40 to +75°C	-40 to +75°C	-40 to +85°C
Operational	(300 ft/m)	(300 ft/m)	(600 ft/m)	At cold wall	At cold wall
Random Vibration	0.002g ² /Hz*	0.002g ² /Hz*	0.04g ² /Hz**	0.1g ² /Hz**	0.1g ² /Hz**
Shock	20g***	20g***	20g***	40g***	40g***

With a flat response to 1000 Hz, 6 dB/Oct roll-off from 1000 to 2000 Hz ** From 10 to 1000 Hz *Peak sawtooth 11 ms duration

About GE Fanuc Intelligent Platforms

GE Fanuc Intelligent Platforms is a leading global provider of embedded computing solutions for a wide range of industries and applications. Our comprehensive product offering includes many types of I/O, single board computers, high performance signal processors, fully integrated, rugged systems including flat panel displays, plus high speed networking and communications products. The company is headquartered in the U.S. and has design, manufacturing and support offices throughout the world. Whether you're looking for one of our standard products or a fully custom solution, GE Fanuc Intelligent Platforms has the breadth, experience and 24/7 support to deliver what you need. For more information, visit www.gefanuc.com.

GE Fanuc Intelligent Platforms Information Centers

Americas:
1 800 322 3616 or 1 256 880 0444

Asia Pacific:
+81 3 5544 3973

EMEA:
Germany: +49 821 5034-0
UK: + 44 1327 359444

Additional Resources

For more information, please visit the GE Fanuc Intelligent Platforms web site at:

www.gefanuc.com

