

# PrPMCQ2

## EmPower Processor PMC

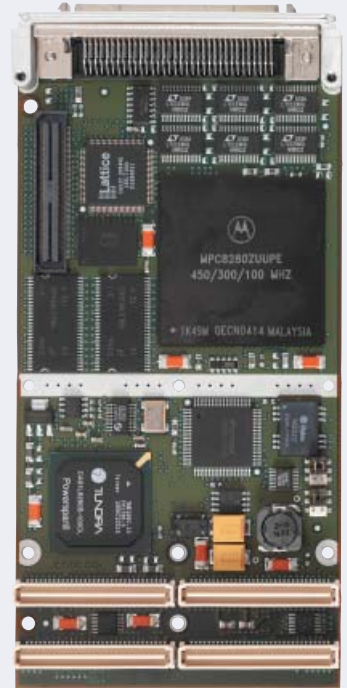

- PowerPC Processor PMC
- PowerQUICC II based
- Fully rugged
- Extensive Radstone software support
- Key features
  - 450 MHz embedded PowerPC 603e
  - Monarch capable
  - Low power consumption (5W typ.)
  - 32 MBytes SDRAM, 16 MBytes Flash
  - 64-bit/66 MHz PCI 2.1 compatible
  - Single 10/100 Base-T Ethernet port
  - 4 high-speed sync/async channels
  - 2 low traffic async channels
  - 4 general purpose I/O lines
  - Deployed Test firmware



A key member of Radstone's EmPower™ family, which offers a range of cost-conscious, comms-orientated products, PrPMCQ2 provides a cost-effective PowerPC processing solution for applications requiring low power consumption and /or a small form factor. Fully rugged for defense and aerospace applications, PrPMCQ2 also offers high speed serial comms and Ethernet interfaces all within a standard PMC form factor.

PrPMCQ2 is ideal for use either as a standalone processing solution or as a mezzanine add-on with Radstone's market-leading families of PowerPC based SBCs. Capable of Monarch or non-Monarch operation, the PrPMCQ2 is based around the latest PowerQUICC II device which offers an embedded PowerPC core at up to 450 MHz, a communications processor at up to 300 MHz and memory interfaces at 100 MHz.

PrPMCQ2 also provides four high-speed serial channels, capable of RS232, 422, 485 operation (software selectable), and configurable for synchronous or asynchronous operation. Two further channels provide additional async capability on lower speed lines. COTS software support includes Radstone's industry leading Deployed Test software, plus async and sync (HDLC) operation under the popular operating systems VxWorks and INTEGRITY.



**RADSTONE**  
TECHNOLOGY

*Why settle for less*

<b>Features</b>		
<b>Processor</b>	MPC8280 PowerQUICC II	Taking advantage of Freescale's 0.13-micron process, the next generation of PowerQUICC II devices offers significant performance increases and power savings over the current generation PowerQUICC II devices, with speeds of up to 450 MHz and 300 MHz in the core and comms. processor respectively – at less than 2 Watts. <b>Core:</b> 450 MHz 603e embedded PowerPC with internal 16 KBytes data and 16 KBytes instruction caches plus floating point unit. <b>Communications Processor Module (CPM)</b> – runs at 300 MHz and off-loads peripheral tasks from the embedded PowerPC core, providing support for multiple communications protocols including 10/100Mbps Ethernet and HDLC channels PrPMCQ2 typical power consumption = 5 to 6W
<b>Main memory</b>	32 MBytes SDRAM	The PowerQUICC II is interfaced to the main memory via a 64bit data bus (main memory = 64-bit, flash memory = 16-bit) running at 100 Mhz
<b>Flash memory</b>	16 MBytes Flash	
<b>Dual port RAM</b>	32 KBytes in PowerQUICC II	
<b>Ethernet interfaces</b>	10/100 Base-T port	Ethernet port provided from the PowerQUICC II
<b>Serial ports</b>	COM 1,2	RS232, provided from the PowerQUICC II
	COM 3,4,5,6,	Async/Sync capable, provided from the PowerQUICC II. All channels are independently software selectable to be RS232/422 or 485
<b>Discrete digital I/O</b>	4-bits	4-bits of TTL compatible discrete digital I/O capable of generating an interrupt
<b>DMA engines</b>	4 available	4 DMA controllers are available for efficiently moving large blocks of data
<b>PCI</b>	Powerspan II	PCI to 60x bridge providing 64-bit/66 MHz PCI 2.1 compliant
<b>Monarch mode</b>	Monarch and non-Monarch operation	The PrPMCQ2 can be used in both processor PMC Monarch and non-Monarch modes, acting as the host for the local PCI bus or as a peripheral on the local PCI bus
<b>JTAG interface</b>	On-card connector	A JTAG header is accessible for both factory test and software debug purposes
<b>Connectors</b>	Front and Rear I/O options available	The PrPMCQ2 is available as either PrPMCQ2R targeted at rear I/O applications from Ruggedization Level 1 to 5 or PrPMCQ2F targeted at front I/O application from Level 1 to 3
		PrPMCQ2R – optional front connector (15way micro-D type) for 2 debug channels and Ethernet (also available from rear) PrPMCQ2R – optional front connector (15way micro-D type) for 2 debug channels and Ethernet (also available from rear)
<b>Software</b>	Full Radstone software support	Includes full initialization Built-in test (BIT), a VxWorks BSP and COMMS module support including Fast Async, HDLC and PCI Transport (PCIT). INTEGRITY support is available from our technology partner Green Hills Systems Inc.

## Radstone Ruggedization Levels

PrPMCQ2R is available in Radstone's five ruggedization levels for use in both convection- and conduction-cooled environments.

PrPMCQ2F is available in Radstone's ruggedization levels 1 to 3 for use in convection-cooled environments

See Radstone's Ruggedization data sheet (RT184) for further details.

<b>Ruggedization Levels</b>	<b>1</b>	<b>2</b>	<b>3</b>	<b>4</b>	<b>5</b>
Cooling Method	Convection			Conduction	
Conformal Coat	Optional	Standard	Standard	Standard	
High Temp Operational	55°C @ 300ft/min	65°C @ 300ft/min	75°C @ 300ft/min	75°C	85°C
				At thermal interface	
Low Temp Operational	0°C	-20°C	-40°C	-40°C	

**Table 1: Radstone's Ruggedization Levels**

Optional Micro-D connector (debug serial ports and Ethernet)

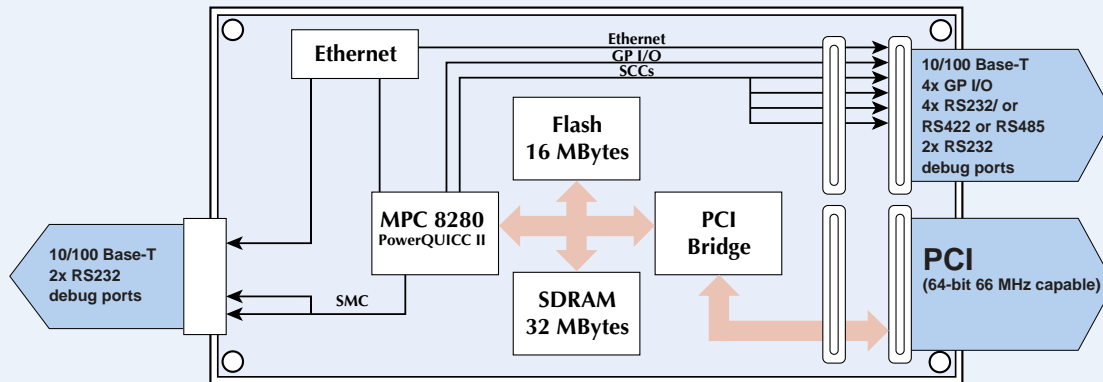

Figure 1: PrPMCQ2R Image and Functional Block Diagram

68-way Honda SCSI connector (all 6 serial ports, GPIO and Ethernet)

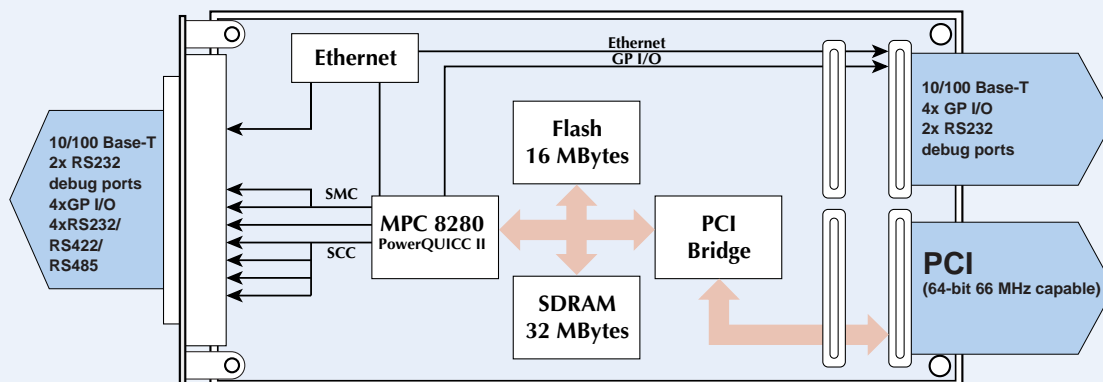
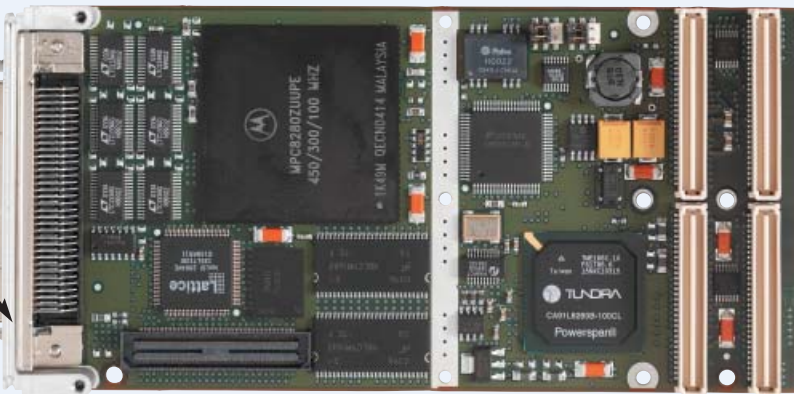

Figure 2: PrPMCQ2F Image and Functional Block Diagram

## ***Software model with VxWorks***

The PowerQUICC II delivers substantial compute bandwidth for flexible communications processing on the PrPMCQ2. This bandwidth can be liberated for deterministic real-time multi-tasking by Wind River Systems' VxWorks Operating System.

Radstone provides a fully featured board support package (BSP) that supports VxWorks 5.5 (Tornado 2.2) and VxWorks 5.4 (Tornado 2.0), plus all generic VxWorks sub-releases subsequent to these main versions. In addition to standard serial tty support, VxWorks TCP/IP network connectivity is provided via the PrPMCQ2 Ethernet port. In Monarch mode a full PCI scan and configuration is performed by the BSP.

Three protocol modules designed to run above VxWorks are also offered, allowing communication-orientated applications a flying start in development. These are:-

1. A Fast Async module for non-synchronous, high-speed, block-orientated serial port operation.
2. An HDLC module for synchronous, high-speed, block-orientated serial port operation.
3. A PCI Transport (PCIT) module for host-board control and optimized data-transfer across PCI.

These modules allow for software configurable operation covering a wide range of baud rates and characteristics, so most applications can use them 'as is'. Source code is available for customer adaptation to less mainstream system configurations.

The PCIT module provides a host board with multi-threaded application access to the PrPMCQ2's resources. It comprises a section that runs on the PrPMCQ2, and a section that runs on the host board into which the PrPMCQ2 is plugged (the host must also be running VxWorks).

Simultaneous host-board connections to HDLC and Fast Async channels may be formed, for mixed operation of differing line-types on individual serial ports. Any application tasks local to the PrPMCQ2 can also form port connections using the same API. This can be useful in development, for adjusting the balance of application loading between host and PMC without having to make significant code alterations. The PCIT performs data transfers across the PCIbus using DMA. Application tasks on the host and PrPMCQ2 may also interact via the PCIT; its interface is generic and not limited just to use with the other Radstone protocol modules.

## ***Software delivery with VxWorks***

Radstone provides the VxWorks BSP, protocol modules, and BIT (see below) as part of the support and services under a Software Maintenance Agreement. There is also a modest run-time charge per target for the protocol modules. The precise Agreement depends on the facilities required, and also any Radstone host-board software that may be needed with the above. Agreements are compulsory for the first year and optionally renewable for annual periods thereafter. Contact your local sales channel for details. The VxWorks / Tornado II Operating System itself is obtained from Wind River Systems.

## ***Software model with INTEGRITY***

With the maximum reliability, royalty-free INTEGRITY Operating System from Green Hills Systems Inc., a similar functional model is supported. In this case all software support is available direct from our technology partner, Green Hills Systems Inc.(GHS).

The same Fast Async and HDLC protocols are supported, and the GHS 'Connection Manager' fulfils the same host/PMC connection function as Radstone's PCI Transport module.

## ***Radstone built-in test software (BIT)***

An optional, high-coverage, initialization BIT resides within its own Flash device on the PrPMCQ2 . BIT also stores its test results in this same Flash device (in addition to giving a visual indication of failure). If the host board into which the PrPMCQ2 is plugged is also a Radstone board running BIT, results data for the PrPMCQ2 will automatically be co-ordinated with results for the host, or indeed results for any other Radstone boards in the whole (VME or CPCI or PCI connected) system. An application task can directly access this data once initialization has completed.

Onboard BIT is ordered via an option field in the hardware part number for the PrPMCQ2. A BIT Maintenance Agreement, providing support and any updates that may be relevant (e.g. to combat obsolescence issues or introduce compatibility with newer Radstone products etc.) is compulsory for the first year after purchase of the hardware with BIT loaded. BIT for the EmPower family of products (which includes the PrPMCQ2) is known as EPBIT. For those customers who wish to absorb Radstone BIT into a proprietary system-test harness, or make other changes not catered for by BIT's wide range of configurability, EPBIT source code is available as a separate item.

## Specification

Function	Hardware Features
4 x SCC	Synchronous & Isosynchronous RS422/RS485 modes to 13 MBaud Asynchronous RS422 / RS485 modes to 1 MBaud Synchronous, Isosynchronous & Asynchronous in RS232 mode to 500 KBaud  SCC electrical mode and data mode independently software configurable
2 X SMC	Asynchronous 120 Kbaud – RS232
1 X Ethernet	10/100 Base-T
4 X GPI/O	3.3V (5.0V tolerant)

## Standard Ordering Information

Sales Code	Description
PrPMCQ2R-133x	Level 1 PMC : 450 MHz PowerQuicc 2 (8280) with 300 MHz comms. processor and 100 MHz memory interface. Single 10/100 Base-T Ethernet port, four high speed RS232/422/485 serial ports, two low speed RS232 ports, four GPIO lines
PrPMCQ2R-233x	Level 2 : as above with conformal coating – air-cooled
PrPMCQ2R-333x	Level 3 : as above with conformal coating – air-cooled
PrPMCQ2R-433x	Level 4 : as above with conformal coating – conduction-cooled
PrPMCQ2R-533x	Level 5 : as above with conformal coating – conduction-cooled
PrPMCQ2F-133x	Level 1 PMC : 450 MHz PowerQuicc 2 (8280) with 300 MHz comms. processor and 100 MHz memory interface. Single 10/100 Base-T Ethernet port, four high speed RS232/422/485 serial ports, two low speed RS232 ports, four GPIO lines
PrPMCQ2F-233x	Level 2 : as above with conformal coating – air-cooled
PrPMCQ2F-333x	Level 3 : as above with conformal coating – air-cooled

x=software option

NOTE: PrPMCQ2R is available on shortest lead time. Consult factory for current lead times on this and the PrPMCQ2F which is likely to be offered on longer lead time.

The standard ordering information (above) defines the standard build variant. Consult your local Radstone sales office for availability of further build options.

### UK

Radstone Technology  
Tove Valley Business Park  
Towcester  
Northants NN12 6PF  
Telephone: +44 (0) 1327 359444  
Facsimile: +44 (0) 1327 322800  
E-mail: sales@radstone.co.uk

### USA

Radstone Technology Corporation  
50 Tice Boulevard  
Woodcliff Lake, NJ 07677-7645  
Telephone: +1 (800) 368-2738  
Facsimile: +1 (201) 391-2899  
E-mail: sales@radstone.com

Eastern Region: +1 (201) 391-2700  
North Central Region: +1 (978) 399-0195  
Central Region: +1 (480) 964 5407  
Western Region: +1 (951) 808 1711

Helpdesk: +44 (0) 1327 322760  
E-mail: support@radstone.co.uk

<http://www.radstone.com>

### CANADA

Interactive Circuits and Systems Ltd  
5430 Canotek Road  
Ottawa, Ontario  
K1J 9G2  
Telephone: +1 (613) 749-9241  
Facsimile: +1 (613) 749-9461  
Toll Free: (US Only) 800 267-9794  
E-mail: info@ics-ltd.com

<http://www.ics-ltd.com>



**RADSTONE**  
TECHNOLOGY

*Why settle for less*