

# PPC7D

## 6U VMEbus PowerPC® Single Board Computer

### Features

- PowerPC 7448 @ 1.4 GHz
- Up to 1 Gbyte DDR SDRAM with ECC
- Up to 512 Mbyte Flash memory
- 2x Gigabit Ethernet
- 2x PCI-X capable PMC sites
- AFIX (Additional Flexible Interface Xtension) site for plug-on AFIX modules
- 2x USB 2.0 ports
- 6x Serial ports
- Parallel port
- Two USB 2.0 ports
- Air and conduction cooled versions
- Comprehensive Deployed Test software
- Comprehensive OS support
- Fully supported by AXIS integrated tools and libraries

PPC7D is a major leap forward for GE Fanuc Intelligent Platforms PowerXtreme single board computer roadmap. It offers a powerful combination of the very latest technology and features, plus full compatibility with the PowerXtreme feature set, first defined in 1995.

The PowerXtreme SBC family is designed explicitly for operation in harsh environments, incorporating state of the art design and manufacturing techniques to guarantee high performance in the most demanding applications.

PPC7D offers the very latest 7448 PowerPC processor, fully supported by the Marvell Discovery III Integrated System Controller providing high data bandwidth to Double Data Rate memory and a bridge to two PCI-X buses.

Two PMC sites and a new AFIX (Additional Flexible Interface Xtension) site provide access to further incremental system expansion.

PPC7D software support includes GE Fanuc Intelligent Platforms' comprehensive Deployed Test software and PPCBoot firmware, plus Board Support Packages (BSPs) and Enhanced Support Packages (ESPs) for VxWorks® from WindRiver, LynxOS® from LynuxWorks, INTEGRITY from Green Hills Systems and Open Source Linux®.

PPC7D not only offers unprecedented performance for new applications, but also protects the user's investment in application software by providing seamless technology insertion opportunities in existing applications.



# PPC7D 6U VMEbus PowerPC Single Board Computer

## Specifications

### Processor

- PowerPC 7448 @ 1.4 GHz
- 1 Mbyte L2 on-chip cache

### DDR2 SDRAM

- Up to 1 Gbyte DDR SDRAM with ECC

### Flash Memory

- Up to 512 Mbyte Flash memory
- Write-protection options

### VME Interface

- Tundra Universe II

### Gigabit Ethernet

- Two 10/100/1000 BaseT ports

### Serial I/O

- Six Total
- COM 1,2: RS232
- COM 3,4: RS232/422 or 485
- COM 5,6: RS232/RS422

### General-Purpose I/O

- One IEEE1284 Parallel Port (build option to replace this with up to 16 bits of TTL-compatible discrete digital I/O)

### USB

- Two USB 2.0 ports

### PMC Extension Slots

- One IEEE 1386/1386.1-2001 compatible extension slots
- PMC – up to 64-bit / 133 MHz PCI-X
- I/O pins to P2/P0

### NVRAM/Real-Time Clock/Watchdog/ETI

- 32 Kbyte non-volatile RAM with Autostore
- Real-Time Clock
- Watchdog timer
- Elapsed Time Indicator (records cycles and on-time)

### Temperature Sensors

- CPU die and ambient temperature

### Power Requirements

- +5 V and 3.3 V - required
- ±12 V - only if required by mounted PMC module

## Block Diagram

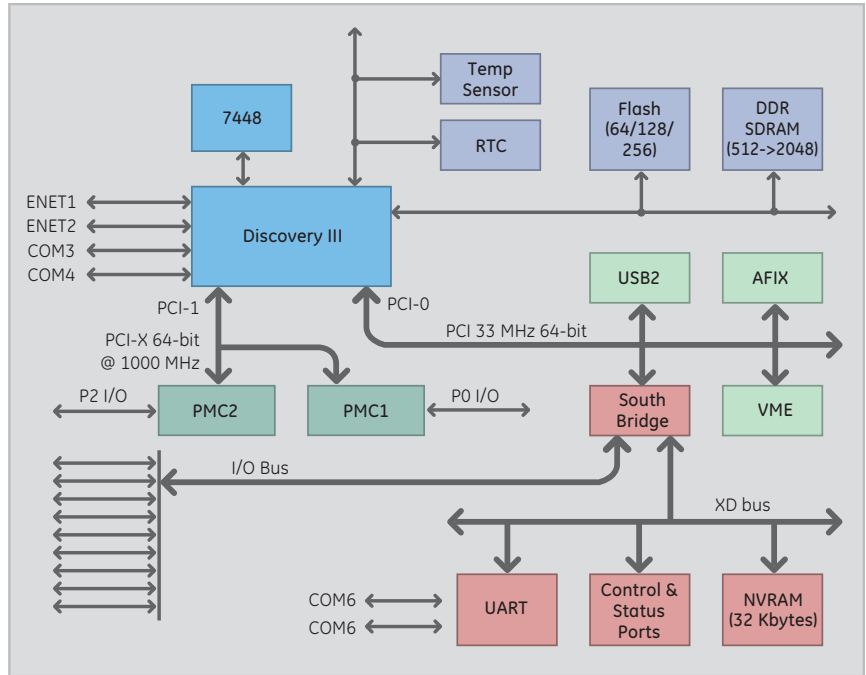

## Environmental

	Level 1	Level 2	Level 3	Level 4	Level 5
<b>Cooling Method</b>	Convection	Convection	Convection	Conduction	Conduction
<b>Conformal Coating</b>	Optional	Standard	Standard	Standard	Standard
<b>High/Low Temp Operational</b>	0 to 55°C (300 ft/m)	-20 to +65°C (300 ft/m)	-40 to +75°C (600 ft/m)	-40 to +75°C At cold wall	-40 to +85°C At cold wall
<b>Random Vibration</b>	0.002g <sup>2</sup> /Hz*	0.002g <sup>2</sup> /Hz*	0.04g <sup>2</sup> /Hz**	0.1g <sup>2</sup> /Hz**	0.1g <sup>2</sup> /Hz**
<b>Shock</b>	20g***	20g***	20g***	40g***	40g***

\* From 10 to 2000 Hz \*\* With a flat response to 1000 Hz, 6 dB/Oct roll-off from 1000 to 2000 Hz \*\*\*Peak sawtooth 11 ms duration

## About GE Fanuc Intelligent Platforms

GE Fanuc Intelligent Platforms is a leading global provider of embedded computing solutions for a wide range of industries and applications. Our comprehensive product offering includes many types of I/O, single board computers, high performance signal processors, fully integrated, rugged systems including flat panel displays, plus high speed networking and communications products. The company is headquartered in the U.S. and has design, manufacturing and support offices throughout the world. Whether you're looking for one of our standard products or a fully custom solution, GE Fanuc Intelligent Platforms has the breadth, experience and 24/7 support to deliver what you need. For more information, visit [www.gefanuc.com](http://www.gefanuc.com).

## GE Fanuc Intelligent Platforms Information Centers

Americas:  
1 800 368 2738 or 1 703 263 1483

Asia Pacific:  
+81 3 5544 3973

Europe, Middle East and Africa:  
Germany: +49 821 5034-0  
UK: +44 1327 359444

## Additional Resources

For more information, please visit the GE Fanuc Intelligent Platforms web site at:

[www.gefanuc.com](http://www.gefanuc.com)

## AXIS Multicomputer

Open Architecture, COTS Multiprocessor Solutions

Customer Application
AXIS Advanced Multiprocessor Integrated Software
Universal Interface Layer (UIL)
Board Support Package (BSP)
Built-in-Test (configurable POST)
I/O, SBCs, Multiprocessors, Fabric switches



**AXIS™**  
Enabled Hardware