



PAC-Xscale

5.7" Flat Panel Computer with User Expandable Memory

Benefits

The PAC-Xscale is our smallest flat panel computer; yet it offers versatility and durability to meet application requirements in any environment. With a 5.7" active matrix color TFT display, the PAC-Xscale requires a minimum amount of space to perform. It can be utilized for applications involving data collecting and trending to system security and alarming.

The PAC-Xscale includes CompactFlash, expandable memory and communication expansion cards. It carries UL; Class 1, Division 2, Groups A, B, C, D; ATEX Class 1 Zone 2; and CE Mark approvals.

Specifications

- Display: 5.7" 320x240 256k color* AMTFT LCD
- CPU: Intel Xscale
- Memory: 32M SDRAM (user expandable to 96M with addition of 64M DIMM); 32M Flash; 512K NV RAM
- Touchscreen: Resistive
- Ethernet: One port 10/100 Mbits/sec; 10BaseT/100BaseTX (auto-detect/auto-switch); Full/Half-duplex, auto-select
- Serial ports: COM1: RS-232/RS-485; COM2: RS-232
- Expansion: One slot
- Memory card: Compact Flash
- USB ports: Two USB 1.1 ports
- Environmental: NEMA 4/4X/12
- Temperature: 0° - 60°C (operating)

- Humidity: 0 - 95% non-condensing
- Fieldbus support: AnyBus-S: Ethernet, Series 90-30 I/O, DeviceNet, Profibus, Genius, Modbus Plus
- Certifications: UL Class 1, Division 2, Groups A, B, C, D; CE Mark; ATEX-Class I Zone 2
- Indicators LEDs: One bi-color (PWR/Sys); one bi-color (user-defined); two on Ethernet connectors
- Operating sys.: Windows CE.NET
- Power: 10.8 - 30.0 VDC; less than 24W
- Dimensions: 6.15" x 4.90" x 2.76" (WxHxD) 156.2 x 124.6 x 70.1 (mm)

Ordering Information

- Part Number: PAC-XS6-<DRAM>

*Video hardware/firmware limits to 65k colors. Specifications may change without notice due to component changes.

**Computer
DYNAMICS**

A GE Fanuc Company

PAC-Xscale 5.7" Flat Panel Computer with User Expandable Memory

Mechanical Drawings

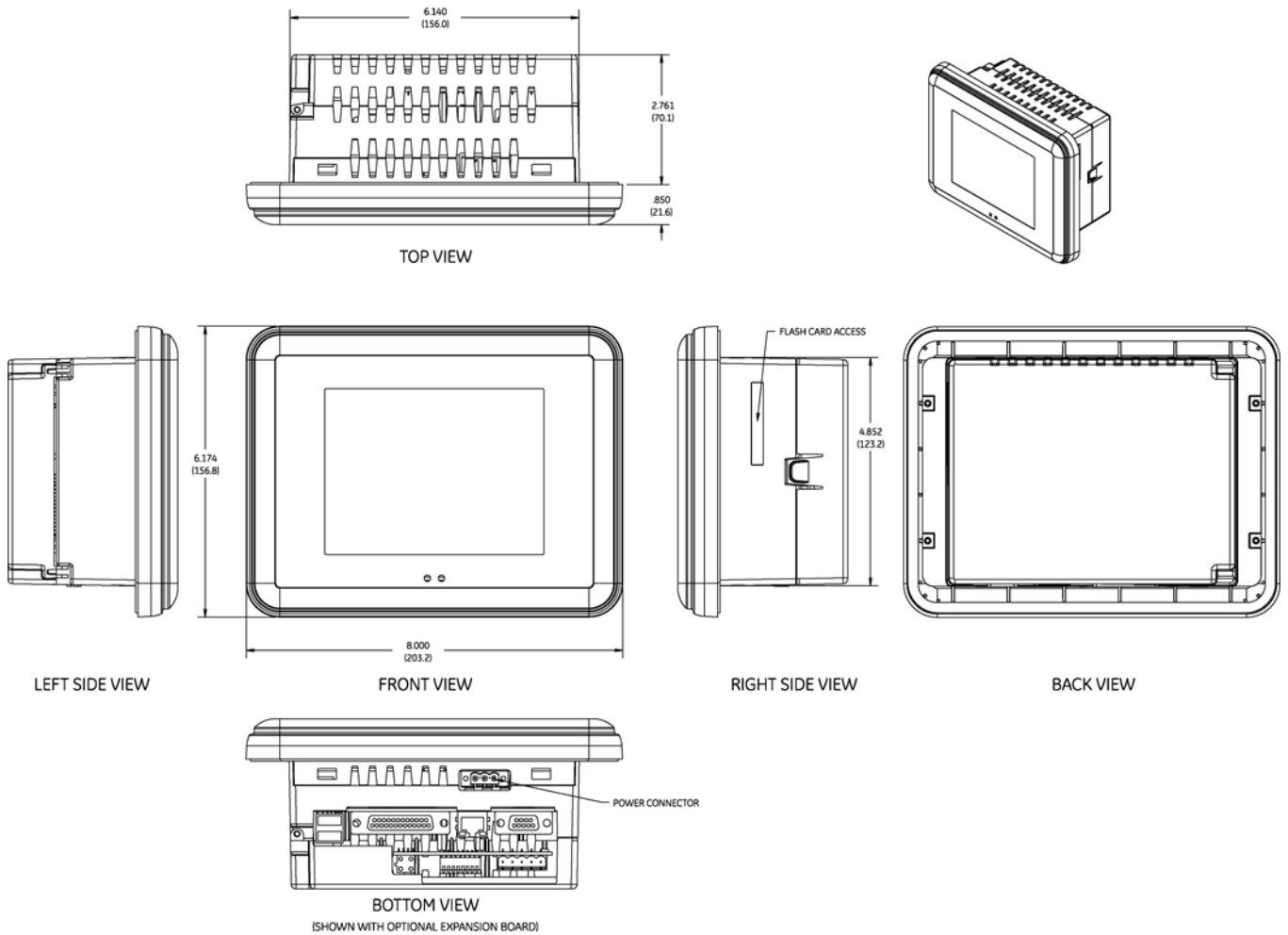

About Computer Dynamics

Computer Dynamics (A GE Fanuc Company) is a leading global provider of flat panel display solutions for a wide range of industries and applications. Our comprehensive product offering includes open-frame, enclosed, and environmentally sealed flat panel display systems in both computer and monitor configurations. The company is headquartered in the U.S. and is a part of GE Fanuc Embedded Systems. Whether you're looking for one of our standard products or a fully custom solution, Computer Dynamics has the breadth, experience and 24/7 support to deliver what you need. For more information, visit www.cdynamics.com.

Computer Dynamics Information Centers

Americas:
1 864 627 8800

Asia Pacific:
86 10 6561 1561

Europe, Middle East and Africa:
33 1 4324 6007

Additional Resources

For more information, please visit the Computer Dynamics web site at:

www.cdynamics.com

Computer DYNAMICS

A GE Fanuc Company

© 2007 Computer Dynamics, Inc. All Rights Reserved.
All other brands or names are property of their respective holders.
Specifications are subject to change without notice.