



# MicroTCA™ MP-2000

## GE Fanuc Modular Platform

### Features

- 2U, 13-slot MicroTCA™ chassis
- MicroTCA backplane supports AMC.0, AMC.1, AMC.2, AMC.3 and AMC.4
- Integrated power subsystem
- Two integrated cooling units (CUs) with EMMC and Telco Alarm function (option)
- Single MicroTCA Carrier Hub (MCH)
- MCH-based PCI Express switch and fabric
- MCH-based Carrier and Shelf Management
- AdvancedMCs included:
  - Telum™ ALSP10 Intel®-based Processor AdvancedMC
  - 2 Telum™ 200-SATA storage AdvancedMCs
  - Telum™ 2001-VGA graphics AdvancedMC
  - Telum™ GE-QT 4-port Gigabit Ethernet AdvancedMC
- 4 single, full-size slots available for additional AdvancedMCs
- One slot supports Full-Size and Compact AdvancedMCs
- JTAG connector on backplane
- IPMI v1.5 compliant
- Designed to meet NEBS
- Pre-installed Linux® operating system Linux Support Package (LSP)
- Supports Hot Swap per AMC.0
- Early-access platforms available to help you define production platform requirements
- RoHS 2002/95/EC compliant

GE Fanuc MicroTCA modular platforms are high-speed, scalable platforms that deliver the performance and flexibility needed for cost-sensitive, network-centric and MicroTCA development applications in a variety of markets including Telecom, Commercial and Military markets. Based on MicroTCA and incorporating the best-of-class system components from GE Fanuc and its ecosystem partners, these modular pre-validated systems deliver true GE quality and reliability.

Pre-validation shortens customer development time by minimizing costly MicroTCA integration and reducing interoperability testing to a minimum. GE Fanuc delivers an application-ready platform that has been tested, including the AdvancedMCs, for mechanical and thermal stability. Plus, proven IPMI code is provided to ensure interoperability and provide a level of platform management including an easy-to-use graphical user interface. Complete platform management is ensured by a Carrier Manager and a Shelf Manager implemented in the MCH.

The small form factor MicroTCA MP-2000 platform includes:

- A 2U chassis with power subsystem
- Dual integrated cooling units (CUs)
- Telco Alarm function (option)
- MicroTCA Carrier Hub (MCH) with PCI Express fabric module
- Telum ASLP10 Processor AdvancedMC

- Two Telum 200-SATA storage AdvancedMCs
- Telum 2001-VGA graphics AdvancedMC
- Telum GE-QT Gigabit Ethernet AdvancedMC.

Four single full-size payload slots are available for additional AdvancedMCs. One of these slots supports Full-Size or Compact AdvancedMCs. A MicroTCA Carrier Management Controller (MCMC) using an Intelligent Platform Management Interface (IPMI) provides the low-level hardware management interface that controls the AdvancedMCs, power subsystem, and CUs.

MicroTCA specified IPMI management, networking, and clock infrastructure are supplied by the MCH. The power subsystem provides power conversion, management, and distribution. Both the MCH and power subsystem provide support for hot insertion and extraction of AdvancedMCs. Direct serial console access to the embedded management firmware is enabled via a front-panel connector on the MCH. A convenient Command Line Interface (CLI) provides easy access and control of the firmware.

GE Fanuc modular platform solutions are fully compliant with open standards such as PICMG MTCA.0 R1.0, AMC.0 R1.0, and the IPMI specifications.

Customer specific configurations and backplane routing are available upon request.



# MicroTCA™ MP-2000 Modular Platform

## IPMI and JTAG Support

The IPMI-based management architecture provides all hardware management support. The MicroTCA Carrier Management Controller (CMCC), located on the MCH, provides the primary management function. Radial IPMB-L connections are routed from the MCH to individual AdvancedMC slots. Dual Redundant IPMB-0 buses are routed from the MCH to the power subsystem and CUs.

A JTAG Switch Module (JSM) connector on the backplane enables a JSM that provides a mechanism for system-level test based on the JTAG architecture in a star topology.

A JSM model supporting this platform is planned.

## Thermals

The 2U chassis has dual front replaceable CUs arranged so that air flows through the chassis from right to left.

## Backplane Interconnect

The platform provides Common Option (CO) and Fat Pipe (FP) region connectivity to each installed AdvancedMC. These are non-blocking Gigabit Ethernet channels to Port 0 of each AdvancedMC slot that are provided by the MCH for CO connectivity. External access to the CO interconnect is available via an RJ-45 connector on the MCH front panel.

X4 PCI Express FP connections to each AdvancedMC slot are supported.

Point-to-point backplane connections between AdvancedMC slot ports 2 and 3 provide support for SATA or SAS AdvancedMCs in the system.

## Linux Support Package

A Linux operating system that uses the included Linux Support Package (LSP) is pre-installed on the platform. The LSP includes Linux drivers for devices on the Telum ASLP10 Processor AdvancedMC as well as for other pre-validated AdvancedMCs.

## Why choose GE Fanuc modular platforms?

GE Fanuc has a wealth of expertise in Military, Commercial and Telecommunications markets. This makes us unique in the embedded computing industry – we understand application requirements and we know communication protocols.

Our line of modular platforms and AdvancedMC I/O products is unmatched. Not only is our product selection extensive, but we leveraged our ecosystem – and it takes a lot to be part of the GE ecosystem – selecting only the best-of-class to create complete, modular platforms that are tested and pre-validated to work seamlessly so that your time-to-revenue is minimized.

GE Fanuc is your one-stop-shop for complete modular platforms, piece parts, customized backplanes and AdvancedMCs. Call GE Fanuc Intelligent Platforms' knowledgeable sales team for help in selecting modular platforms and AdvancedMC products that best meet your application requirements.

## Platform Configuration

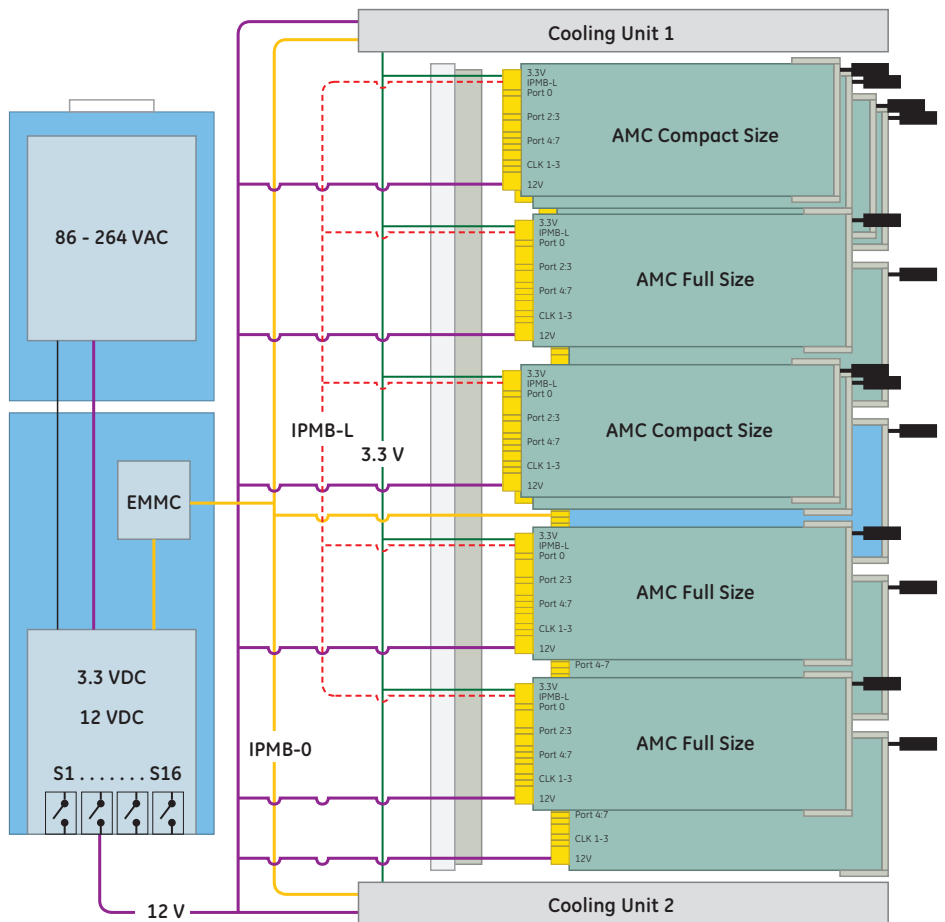

## Specifications

### Chassis

- 2U chassis: 86.36 x 482.6 x 254 mm (HxWxD)
- \* Weight: 8.2 kg pre-configured
- 13 slots: one slot occupied by MCH
- Designed for NEBS and EN levels Backplane
- Backplane support
  - 1x Gigabit Ethernet on Port 0
  - 2x SATA/SAS on Ports 2 & 3
  - 4x PCI Express on Ports 4, 5, 6 & 7
- MicroTCA backplane supports AMC.0, AMC.1, AMC.2, AMC.3 and AMC.4 specifications
- JTAG connector for debug and test
- AdvancedMC connectors based on con:card+ design
- Processor AdvancedMC can communicate with adjacent SAS/SATA module via point-to-point connection

### MCH

- MCMC supports up to 12 AdvancedMCs, up to two PMs and up to two CUs
- Support for 12 Gigabit Ethernet ports Fabric A (routed to AdvancedMC Port 0)
- Supports one Gigabit Ethernet port, connected to Fabric A, on the front panel
- Supports one 10/100/1000BaseT Ethernet port on the front panel
- Supports x4 PCI-E to all AdvancedMCs
- Carrier Manager processor
- Integrated Shelf Manager with Open HPI interface
- Application providing a Graphical User Interface (GUI) and communicating via Open HPI is included
- PCI Express fabric switch module
- Clock support: two Telecom clocks and one fabric clock (spread-spectrum PCI-E clock)
- Front panel connector for bidirectional external reference clock
- Status and hot swap LEDs
- Front panel connectors for serial debug
- Compliance
  - PICMG AMC.0 R1.0
  - PICMG AMC.1 R1.0 Type 4
  - PICMG AMC.2 R1.0 Type E1
  - PICMG MTCA.0 R1.0

### Integrated Power Subsystem

- 450W power budgeted
- AC input 86-264V
- Provides management and payload power to 12 AdvancedMCs, one MCH, and two CUs
- Status LEDs

### Cooling Units (CUs)

- Two CUs with 2 fans each (push & pull)
- The CUs provides up to 31 cfm (52.8 m<sup>3</sup>/h) at 82% fan speed.

### Telco Alarm

- Telco Alarm function provided

### System Mounting

- Use standalone or mounted in a 19-inch rack

### Environmental

- Temperature
  - Operating: 0° to +55 °C
  - Storage: -40° to +85 °C
- Relative Humidity
  - Designed to meet NEBS
- Shock & Vibration
  - Designed to meet NEBS

### MTBF

- Contact GE Fanuc Intelligent Platforms

### Safety

- All PCBs are manufactured with flammability rating of 94V-0

### EMC Requirements

- Designed to meet NEBS

### Regulatory Compliance

- FCC Part 15, Class A
- Designed to meet UL60950-1
- CSA C22.2
- Designed to meet EN60950-1
- EN55024/EN55024

## Specifications: Included AdvancedMCs

### Telum™ ASLP10 Processor AdvancedMC

- Low power Intel® Pentium® M processor LV, 1.4 GHz, 2 MB L2
- Single, full-size AMC.0 form factor
- One GB DDR2 SDRAM (400 MHz) with ECC
- Two GB Flash drive
- Two Gigabit Ethernet ports
  - AMC.2 E2 routed to Port 0 & 1
- Two SATA ports
  - AMC.3 Type S2 on ports 2 & 3
- PCI Express x8 data port
  - AMC.1 Type 8 on ports 4 - 11
- One USB 2.0 port on front panel
- Fabric clock input (FCLKA for SS PCI Clock)
- Watchdog, temperature sensor

### Telum™ 200-SATA Storage AdvancedMC

- Serial ATA (SATA) hard disk drive with 80GB capacity
- Single, full-size AMC.0 form factor
- Single SATA port, selectable for either Port 2 or 3 connectivity
- Support for SATA (150 MB/s) interface
- Fast read/write performance

### Telum™ 2001-VGA Graphic AdvancedMC

- Resolution of 1024 x 768 pixel x 24 bit at 60 Hz
- Single, full-size AMC.0 form factor
- x1 PCI-E interface, Port 4
- Single display device
- DB15 connector

### Telum™ GE-QT Gigabit Ethernet Interface AdvancedMC

- Four Gigabit Ethernet ports
- Single, full-size AMC.0 form factor
- x4 PCI-E interface, Ports 4-7
- 10/100/1000BaseT
- TCP CRC calculation and segmentation offloading
- 802.1Q VLANs, with up to 4096 VLANs
- Accommodates Ethernet Jumbo frames (16 KB)

For detailed specifications, see individual datasheets: <http://www.gefanuc.com>.

# MicroTCA™ MP-2000 Modular Platform

## Ordering Information

### MP200001

MP2000 MicroTCA-based 13-slot modular platform with 2U chassis with integrated AC power subsystem, 2 CUs, 1 MCH with PCIe fabric, Telum ASLP10 Processor, 2 Telum 200-SATAs, Telum 2001-VGA, Telum GE-QT, Pre-installed Linux operating system and with LSP and Linux drivers.

### Telum™ AdvancedMCs Available from GE Fanuc

#### Telum GE-QLX LAN I/O

4-port 1000BaseLX Gigabit Ethernet NIC

#### Telum GE-QSX LAN I/O

4-port 1000BaseSX Gigabit Ethernet NIC

#### Telum GE-QT LAN I/O

4-port 10/100/1000BaseTX Gigabit Ethernet NIC

#### Telum 2001-VGA Platform and Development Enabler

High-resolution CRT video graphics adapter

#### Telum GPSTC-AMC Platform and Development Enabler

GPS clocking

#### Telum ASLP10 Processor AMC

Intel Pentium M processor; dual Gigabit Ethernet channels

#### Telum 210 SAS Storage

SAS hard disk drive and SAS controller

#### Telum 200-SATA Storage

SATA hard disk drive

#### Telum NPA-58x4 Packet Processor

Supports OCTEON Plus processor

#### Telum NPA-3804 Packet Processor

Supports Cavium OCTEON Secure Communications Processor

#### Telum 624/628-TEJ WAN I/O

4 or 8 T1/E1/J1 ports

#### Telum 1001-O12M/S WAN I/O

Full duplex OC-12 ATM interface

#### Telum 1001-O3 WAN I/O

OC-3 ATM interface with traffic management & APS

#### Telum 1004-O3M/S WAN I/O

4-port OC-3 interface

#### Telum 1001-DE WAN I/O

OC-3 ATM interface

#### Telum 1204-O3 WAN I/O

Intelligent multi-service OC-3/STM1 interface

#### Telum FC2432 Fibre Channel

4 Gb/s Fibre Channel HBA

#### Telum FC2312-CC Fibre Channel

2 Gb/s Fibre Channel HBA; supports copper cable

#### Telum FC2312-FF Fibre Channel

2 Gb/s Fibre Channel HBA; supports fiber-optic cable

## Block Diagram

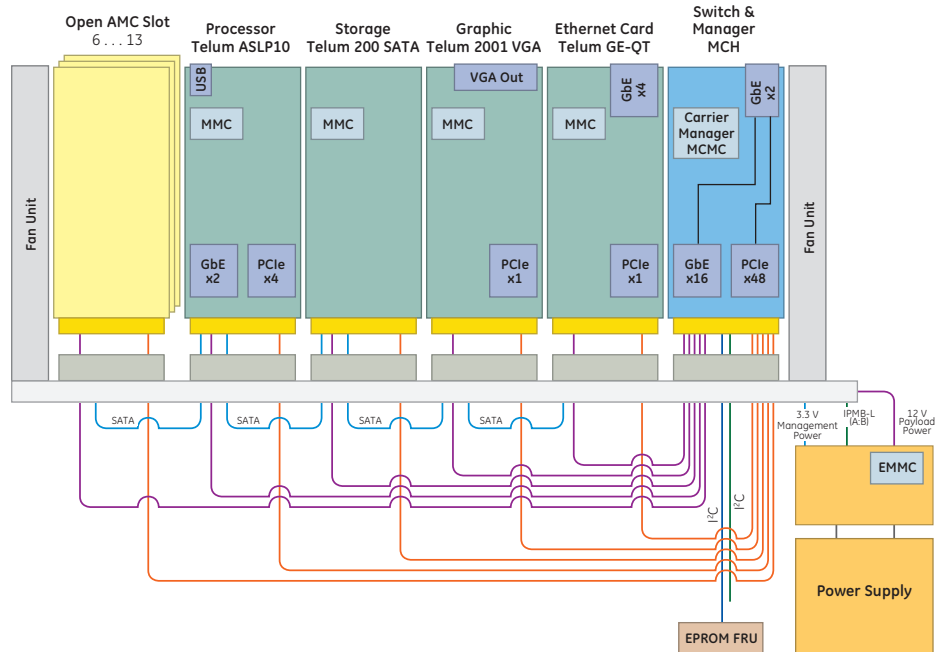

## About GE Fanuc Intelligent Platforms

GE Fanuc Intelligent Platforms is a leading global provider of embedded computing solutions for a wide range of industries and applications. Our comprehensive product offering includes many types of I/O, single board computers, high performance signal processors, fully integrated, rugged systems including flat panel displays, plus high speed networking and communications products. The company is headquartered in the U.S. and has design, manufacturing and support offices throughout the world. Whether you're looking for one of our standard products or a fully custom solution, GE Fanuc Intelligent Platforms has the breadth, experience and 24/7 support to deliver what you need. For more information, visit [www.gefanuc.com](http://www.gefanuc.com).

## GE Fanuc Intelligent Platforms Information Centers

Americas:

1 800 322 3616 or 1 256 880 0444

Asia Pacific:

+81 3 5544 3973

EMEA:

Germany: +49 821 5034-0

UK: + 44 1327 359444

## Additional Resources

For more information, please visit the GE Fanuc Intelligent Platforms web site at:

[www.gefanuc.com](http://www.gefanuc.com)

