

IVD2015

Rugged Intelligent Vehicle Display

Features

- 15" rugged touchscreen LCD display
 - XGA, 1024 x 768 @ 60 Hz
 - 8-bit color depth display
 - MIL-STD-3009 NVIS compatibility
 - 5-wire resistive touchscreen
 - Portrait mounting option available
- Low power, high performance graphics computer
 - Intel Core2 Duo @ 2.26GHz
 - 4 GB DDR3 SDRAM
 - 8 GB Flash
 - Optional 64 to 256 GB encrypted Flash
 - 96-core NVIDIA GT 240 GPU
- Multiple simultaneous video inputs
 - Four RS-170, NTSC channels
- Slave display option
 - DVI output to drive slave display
 - May clone internal LCD output, or be independent
- Comprehensive I/O
 - Two Gigabit Ethernet channels
 - Two serial RS-232 channels
 - Two USB 2.0 channels
 - Stereo line-in, stereo line-out
 - Optional two ports 10 Gigabit Ethernet fiber, 10GBASE-SR
 - Optional CANbus / MilCAN
 - Optional MIL-STD-1553

The Intelligent Vehicle Display family is built around a core video processing architecture with low power and high performance computing capability, providing the capabilities required by military land vehicles.

The IVD2015 incorporates a 15" LCD display, with a resolution of 1024 x 768 XGA, with exceptional uniformity across the display. High intensity LED backlighting provides sunlight readability. A 5-wire resistive touchscreen allows for optimum usability and durability.

The display glass is toughened to withstand the rigors of in-vehicle use, and incorporates filters for MIL-STD-3009 NVIS compatibility. The complete display stack is laminated using a controlled process for highest quality and durability.

The IVD2015 has 30 bezel keys whose function may be assigned by the application software, together with 2 fixed function buttons; on/off, brightness up/down, night vision mode.

The Intelligent Vehicle Display has four simultaneous video inputs. Each of these video inputs can be optionally scaled to create thumbnails or full-screen images, or to mirror the video input, e.g. for viewing rear-mounted cameras.

The IVD2015 brings incoming video into the GPU allowing picture-in-picture and symbology overlay on all of the video inputs, simultaneously if necessary, together with the ability to stitch multiple videos into a single panorama.

In addition to the analog video inputs, the IVD2015 has two ports of 10 Gigabit Ethernet allowing it to be connected directly



to the video backbone of the vehicle, and thus able to subscribe directly to multiple video channels, for example in situational awareness applications.

The computing node comprises the Penryn Core2 Duo processor together with an Intel GM45 and an NVIDIA GT 240 GPU. It is capable of generating two separate video graphics channels.

The combination of Intel Penryn Core2 Duo and NVIDIA GT 240 offers very attractive performance and power efficiency, and a balance can be struck by derating the GPU clocks if necessary.

The IVD2015 can be built with one of a range to Core2 Duo processors to match application requirements and limit power dissipation, and with up to 4 GBytes of system memory. Connecting to the GPU via 16-lane PCI Express, this gives maximum bandwidth for demanding graphics applications.

In addition to outstanding graphics performance, the NVIDIA GT 240 includes several key technologies, including PhysX and CUDA.

NVIDIA PhysX® is a powerful physics engine enabling real-time physics in 3D applications. PhysX is optimized for hardware acceleration by the GPU providing an exponential increase in physics processing power taking gaming physics to the next level for simulations, such as embedded training.

CUDA is NVIDIA's parallel computing architecture that enables dramatic increases in computing performance by harnessing the power of the GPU for general purpose computation, enabling a range of capabilities such as IED detection processing, and line of sight calculation for navigation planning.



IVD2015 – Rugged Intelligent Vehicle Display

Specifications

Display

- 15" rugged LCD display
- XGA, 1024 x 768 @ 60 Hz
- MIL-STD-3009 NVIS compatibility
- 5-wire resistive touchscreen
- 30 bezel keys
- Portrait mounting option available

CPU

- Intel Core2 Duo processor
 - SP9300 @ 2.26 GHz
- 4 GB DDR3 SDRAM
- 8 GB Flash
- Optional 64 to 256 GB AE-128 encrypted Flash GPU
- NVIDIA GT 240
- 96 cores
- 1 GB DDR3 SDRAM

Video inputs

- Multiple simultaneous video inputs
- Low latency
- Four NTSC/RS-170 channels

Video scaling

- Independent X and Y scaling factors

Slave display option

- DVI output to drive slave display
- May mirror internal LCD, or be an independent channel

I/O

- Two Gigabit Ethernet channels
- Two serial RS-232 channels
- Four USB 2.0 channels
- Stereo line-in, stereo line-out
- Optional MIL-STD-1553
- Optional CANbus/MilCAN
- Optional two ports 10 Gigabit Ethernet, 10GBASE-SR

Environment

- -46° C to +55° C operating
- Natural convection cooling
- MIL-STD-1275 28 VDC input
- MIL-STD-461F Ground, Army

Block Diagram

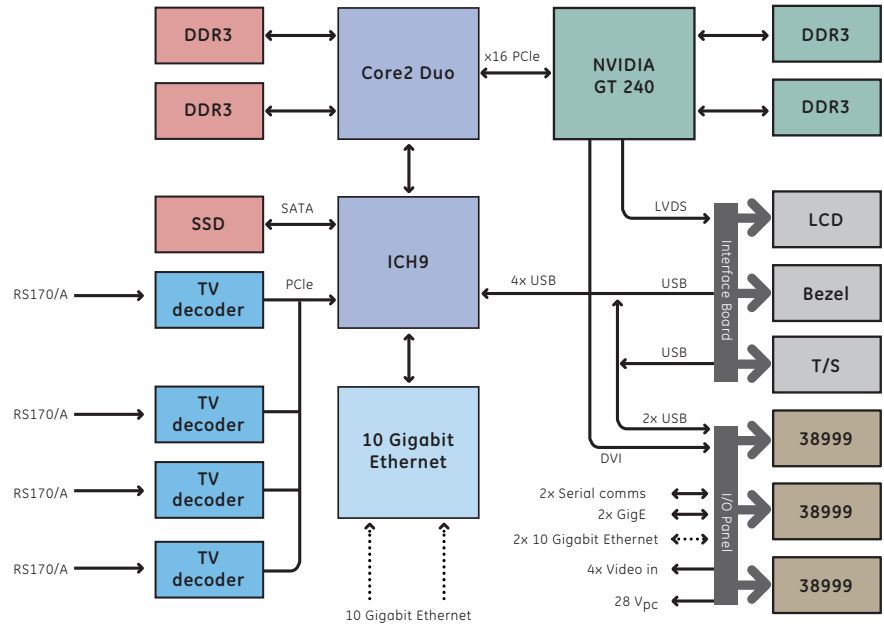

Ordering Information

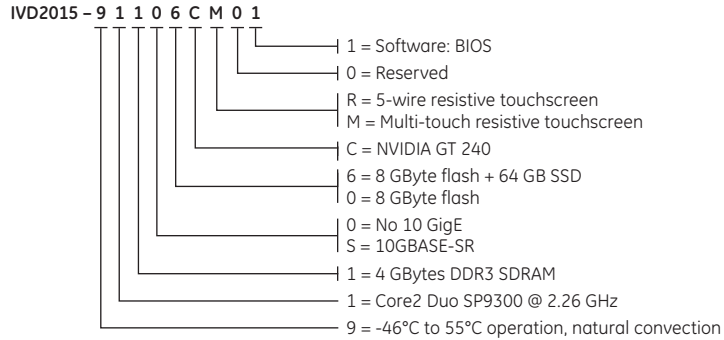

Contact GE for other display and processing configurations.

About GE Intelligent Platforms

GE Intelligent Platforms is a division of GE that offers software, control systems, services, and expertise in automation and embedded computing. We offer a unique foundation of agile and reliable technology providing customers a sustainable competitive advantage in the industries they serve, including energy, water, consumer packaged goods, oil and gas, government and defense, and telecommunications. GE Intelligent Platforms is headquartered in Charlottesville, VA. For more information, visit www.ge-ip.com.

GE Intelligent Platforms Contact Information

Americas: 1 800 433 2682 or 1 434 978 5100

Global regional phone numbers are listed by location on our web site at www.ge-ip.com/contact

defense.ge-ip.com

