

CC11

High Performance – 3U Compact PCI® Dual Slot Dual Core Processor Board

Features

- Intel® Core 2 Duo® processor, 1.5 GHz
Intel® Core Duo® processor 1.2, 1.66 and 2 GHz
- Up to 4 MB L2 cache
- Ultra compact all-in-one PC
- System or Non-system (peripheral mode)
- System slot for 32-bit CompactPCI backplane
- Up to 2 GB DDR2 SDRAM
- Flash drive or local hard disk
- VGA interface/SDVO interface
- Up to four Gigabit Ethernet ports
- Enhanced IDE UDMA-100
- 3x Serial ATA
- 2x serial I/O with FIFOs, RS-232 interface
- 6x USB 2.0
- Optional audio interface
- Watchdog, temperature sensor
- 5 V / 3.3 V supply
- Optional -40° C to +75° C
- RoHS compliant

CC11 is a high-performance 3U CompactPCI® CPU board using the Intel® Core Duo or the Intel® Core 2 Duo® Processor incorporating sophisticated power management technology, eliminating the need for an onboard fan. The CC11 can be ordered as a system or non-system slot single board computer.

CompactFlash is available as an option.

It contains an integrated SATA or EIDE hard disk or CompactFlash. It offers the user the choice between a DVI interface or a COM2 port on the front. In place of the dual Ethernet ports an audio interface can be available based on an order option.

The CC11 supports up to four Gigabit Ethernets, up to 2 GByte of DDR2 SDRAM and VGA/SDVO. At the heart of the CC11 design is a high-bandwidth 667MHz bus connecting the processor, chipset and PC2-5300 DDR2 SDRAM. In addition there are six USB 2.0 ports, two serial channels, and three serial ATA channels. Interfaces are available as front- and/or rear-I/O. The CC11 is available in standard temperature range 0° C to +70° C, and optional in extended from -40° C to +75° C. Custom specific versions are available on request.

The CC11 is a powerful processor platform for a wide range of applications and markets such as multimedia, automation, transportation, as well as imaging, medical, robotics, and many others. The CC11 is very suited to low-power embedded computer applications in a small form factor where optimal performance and functionality is required.

The CC11 is RoHS compliant.

For a single slot 3U CompactPCI SBC, refer to the CL11 dual core processor board.

CC11 - 3U Compact PCI® Dual Slot Dual Core Processor Board

Specifications

Processor - μ FCBGA, Low Power design

- Scalable processing power with flexible processor design
- Intel Core Duo processor U2500: 1.20 GHz
- Intel Core Duo processor L2400: 1.66 GHz
- Intel Core Duo processor T2500: 2.00 GHz
- Intel Core 2 Duo processor L7400: 1.5 GHz
- High efficiency on-board switching regulator (DC/DC)
- Fanless cooling with heat sink
- Contact factory for latest CPU versions

Cache	Level 1	Level 2
Core Duo	32 KB	2 MB, full speed
Core 2 Duo	32 KB	4 MB, full speed

Chipset – Intel 945GM with Intel ICH7R

- 533/667 MHz system bus to processor
- One PCI Express x4 or four PCI Express x1 interfaces
- Two PCI Express x1 interfaces
- Data throughput between 945GM and ICH7R is theoretically 2 GB/s (1 GB/s each direction)

Memory – DDR2 667

- Single-/Dual-Channel DDR2 SDRAM
- High-speed 667 MHz (PC2 5300) DDR2 SDRAM
- 64-bits wide / 128-bits wide
- 512 MB to 2 GB with soldered chips

CompactPCI

- PICMG 2.0 R3.0 compliant CPC1 32bit/66 MHz local bus standard
- Backplane with rear I/O
- System or non-system (peripheral) PCI Bridge Pericom PI7C9X110 for up to 7 slots
- J1+2, 2 mm pin and socket connectors (IEC-1076-4-101)

Gigabit – Two Realtek RTL8111B

- Highly integrated Single Gigabit Ethernet Controller with PCI Express x1 interface
- 64 KB Transmit and Receive FIFO
- 10/100/1000BaseT auto-negotiation
- Port 1 and Port 2 for front or rear I/O. Solder option.
- Port 3 and Port 4 for front I/O. Depends on product version

Hard Disk or Flash Drive

- EIDE and SATA interfaces on header connector
- One 2.5" SATA/EIDE hard disk or one Compact Flash connector (for extended temperature range and higher shock/vibration immunity)

VGA and LCD - Chipset Integrated

- 2D & 3D graphics engine
- DirectX 9.1 support
- Up to 64 MB of dynamic video memory allocation
- Integrated 360 MHz 24-bit RAMDAC for analog VGA monitors up to 1600 x 1200, 75 Hz
- Display image rotation
- Graphics power management
- VGA at front or rear I/O
- SDVO at connector, with extension card DVI-D support possible

EIDE

- Ultra ATA/100 sync. DMA mode up to 90 MB/s
- PIO mode 4 and bus master IDE up to 16 MB/s
- Onboard devices supported via local header

SATA

- Two serial ATA at rear I/O
- One SATA interface on header connector
- DMA mode up to 150 MB/s

Serial I/O - RS232

- Integrated in SMSC SCH3112 Super I/O
- Two async. 16550 compatible full duplex serial channels
- High-speed transfer up to 115.2 kbaud with 16 byte FIFOs
- COM1 available at rear I/O
- COM2 optional available at front (8 HP)
- COM2 interface supports RS232, opto RS232/485

Audio Interface - optional

- S/PDIF digital output (optical)
- Line in
- Headphone out

General Purpose Input/Outputs

- Integrated in SMSC SCH3112 Super I/O
- 8 bits programmable general purpose inputs/outputs

USB 2.0

- Six USB 2.0 connectors. Three on front, three on rear I/O.

Keyboard

- Via USB (supports legacy keyboard/mouse SW)

Mouse

- Via USB (supports legacy keyboard/mouse SW)

Real-time clock

- Integrated in chipset
- RTC 146818 compatible, on-board Li-battery

CMOS RAM

- 114 bytes non-volatile CMOS RAM for BIOS data

EEPROM

- 512 Kbit (64 KB) serial EEPROM for non-volatile user data

Floppy

- Via USB port

Watchdog

- Integrated in chipset
- Two stage watchdog with independent count values
- First stage drives NMI or SMI, second stage drives reset
- Configurable granularity from 1 μ s to 10 min

Timer

- Integrated in chipset based on 82C59
- Includes three timer comparators
- One-shot and periodic interrupts supported

CC11 - 3U Compact PCI® Dual Slot Dual Core Processor Board

Temp. Sensor

- CPU die and heat sink temperature software readable from -65° C to +127° C

LED

- Two LEDs at front panel

BIOS Features

- New AMI BIOS Core 8, in-system programmable Flash ROM
- Automatic system configuration
- Integrated VGA, SATA RAID and Ethernet PXE ROM
- USB Mass Storage support
- Password protection
- Headless support
- Remote console through serial port

Software

- The following software is supported to the extent listed below.

OS	On Request	Available
WIN XP	-	√
QNX 6	√	-
VxWorks	-	√
Lynx OS	√	-
Linux	-	√

Front and Onboard I/O with standard Front Panel

Function	Single Board Computer CC11		
	Front I/O	Onboard I/O	Rear I/O
Gb Ethernet 0	RJ-45*1		Yes*1
Gb Ethernet 1	RJ-45*1		Yes*1
USB 0	USB		
USB 1	USB		
USB 2 to 4			Yes
VGA	D-15		Yes
EIDE		Misc.Header	
SATA 1 / 2			Yes
COM 1			Yes
GPIO (8 pins)			Yes
Power button	Button		
Reset			Yes
Speaker			Yes
LED	Yes		
Keyboard, Mouse, Floppy	Via USB		Via USB
USB 5	USB		
SDVO	DVI-D*2		
EIDE		HDD or CFlash connector	
SATA 3		HDD connector	
COM 2	D-15		
Gb Ethernet 2	RJ-45		
Gb Ethernet 3	RJ-45		
Audio I/F*3	Line Out Line In S/PDIF Out		
Speaker		Yes	

*1 Front- or Rear-IO as a solder option

*2 Possible with special extension card, COM2 front I/O not available

*3 Only available for operating temperature ≥ 0° C

Power Requirements

- +5 V, +3.3 V Required

Power Consumption - typical operating current (est.)

- TBD

Mechanical - PICMG 2.0

- 3U, 2 slot wide (100 x 160 x 40.64) mm with 8HP Front panel
- CC11 in backplanes with right justified system slot occupies one CPCI slot only.

Temperature

- Note: For detailed information about the operating temperature behavior of the board it is absolutely necessary to consult the manual. The highest achievable operating temperature depends on processor type, speed, ambient conditions (air flow) and front plate width.
- All values under typical conditions.

	Operating	Storage
Standard	0° C to +70° C	-40° C to +85° C
Extended	-40° C to +75° C	-40° C to +85° C

Humidity

- Operating: 5 - 95 % @ 40° C
- Storage: 5 - 95 % @ 40° C

Altitude

- Operating: 15,000 ft. (4.5 km)
- Storage: 40,000 ft. (12 km)

Shock (3 axis, up & down, 5 hits / direction)

- Styles 1, 3: 12 g / 6 ms

Vibration (60 minutes each axis)

- Styles 1, 3: 2 g rms @ 5 to 100 Hz

VITA 47

- Designed to meet VITA47 class EAC1 and EAC3

MTBF

- Calculations are available in accordance with MIL-HDBK-217. Please contact GE Fanuc Intelligent Platforms.

Safety

- Designed to meet standard UL 1590, CE class A, FCC-A

CC11 - 3U Compact PCI® Dual Slot Dual Core Processor Board

Block Diagram

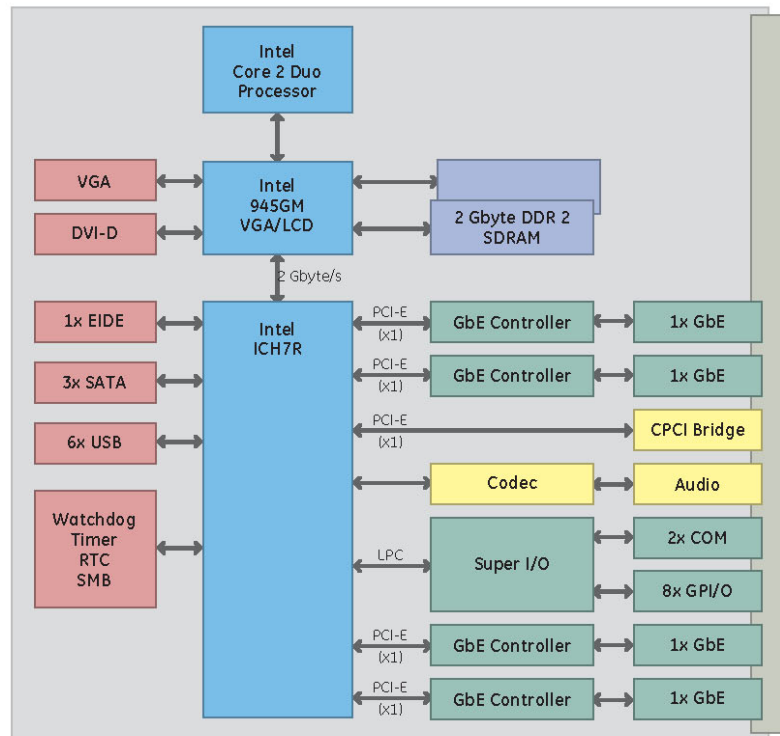

Ordering Information

Hardware Accessories

CTM18: I/O transition module for 3U backplane

SCC484TB05CC11R: Starter cage 19" 4U, 5 slots, with fans, power supply, CDROM and hard disk, 0° C to +40° C

Operating Systems

Extensive operating systems support is available (see page 3). Chassis with power supplies, backplanes and drives on request. For detailed information and further options, contact GE Fanuc Intelligent Platforms.

About GE Fanuc Intelligent Platforms

GE Fanuc Intelligent Platforms is a leading global provider of embedded computing solutions for a wide range of industries and applications. Our comprehensive product offering includes many types of I/O, single board computers, high performance signal processors, fully integrated, rugged systems including flat panel displays, plus high speed networking and communications products. The company is headquartered in the U.S. and has design, manufacturing and support offices throughout the world. Whether you're looking for one of our standard products or a fully custom solution, GE Fanuc Intelligent Platforms has the breadth, experience and 24/7 support to deliver what you need. For more information, visit www.gefanuc.com.

GE Fanuc Intelligent Platforms Information Centers

Americas:
1 800 322 3616 or 1 256 880 0444

Asia Pacific:
86 10 6561 1561

Europe, Middle East and Africa:
33 1 4324 6007

Additional Resources

For more information, please visit the GE Fanuc Intelligent Platforms web site at:

www.gefanuc.com

