

MVME8110

Freescale P5010 QorIQ VME320 SBC

Data Sheet

- Freescale QorIQ P5010 1.2GHz
- Up to 4 GB DDR3-1200 MHz ECC Memory
- 512 KB MRAM
- 2 PMC/XMC sites
- Embedded NAND Flash (8GB eMMC)
- Up to 3 USB 2.0 ports
- Up to 3 Ethernet ports
- Up to 5 Serial ports
- 2 GPIO

The Artesyn Embedded Technologies MVME8110 is a high performance 6U VME SBC featuring the Freescale P5010 QorIQ processor supporting high speed DDR3-1200 MHz with ECC. It offers multiple USB, Serial and Ethernet ports. Memory includes up to 4 GB DDR3, 512 KB MRAM non-volatile memory, and 8 GB eMMC NAND Flash.

It is designed for a range of high end industrial control such as SPE and photo lithography and C4ISR, including Radar/Sonar. It will provide technology insertion to prolong current programs while providing more computing performance and data throughput.

The MVME8110 supports a full range of BSPs including Linux, Wind River VxWorks, and Green Hills Integrity.

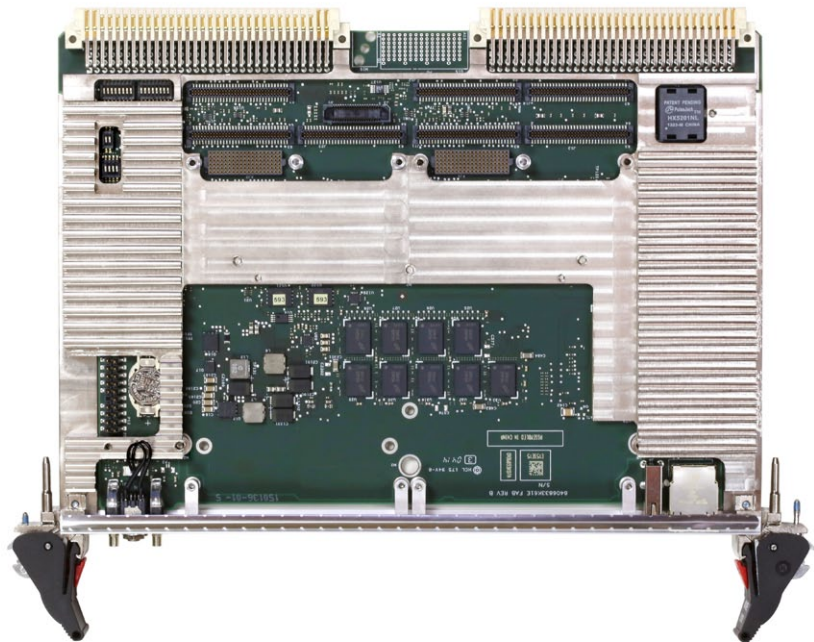

MVME8110 Block Diagram

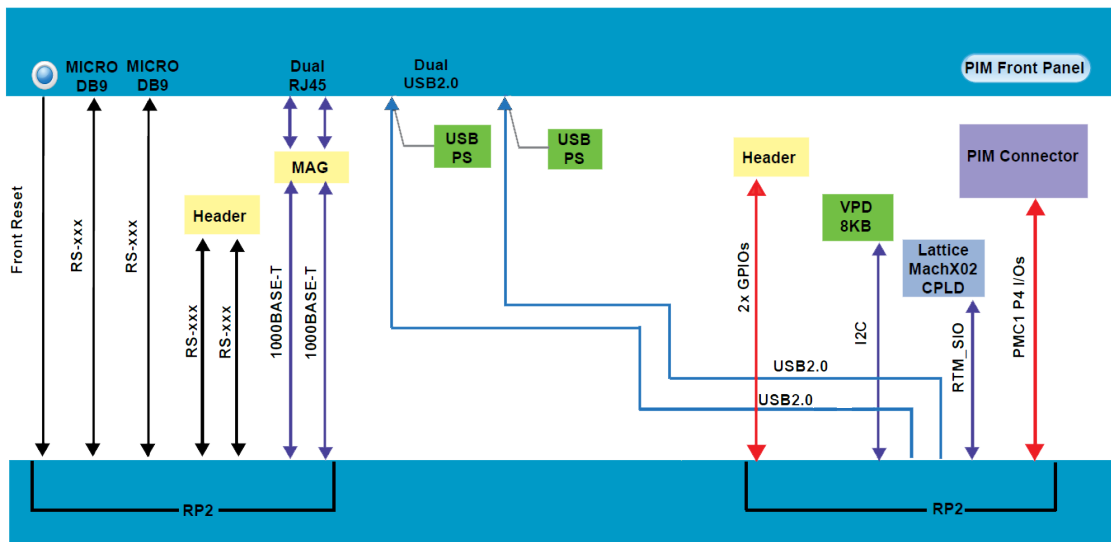
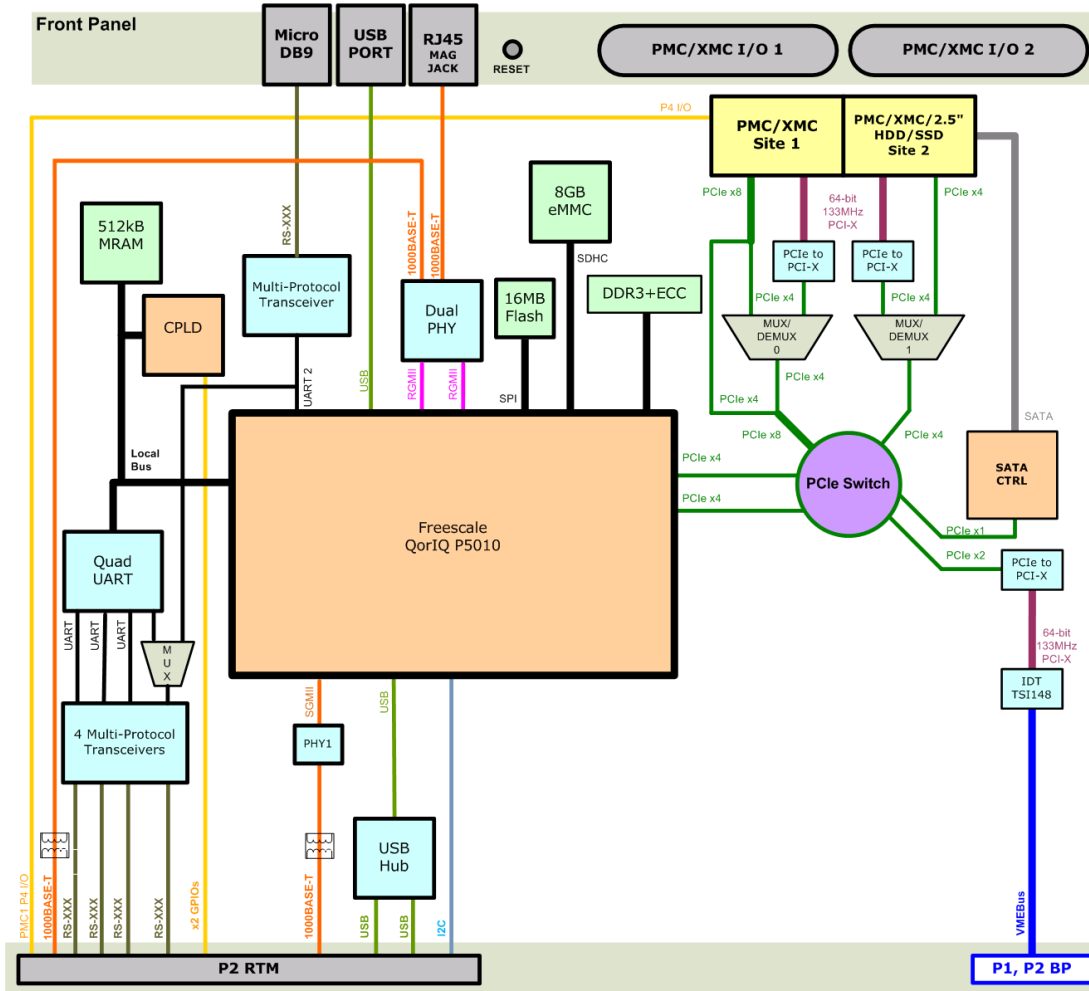

Hardware Specifications

PROCESSOR

- Freescale QorIQ P5010
- 1.2GHz: ENP1 variants

MEMORY

- Designed for 4GB of 64 bit DDR3-1200 ECC SDRAM soldered down
- 16MB SPI ROM for boot code (in 1+1 redundant 8MB banks/devices)
- 512 KB MRAM for data storage
- 8GB NAND Flash with SD/EMMC interface

BACKPLANE I/O

- P1
 - VME64x & 2eSST
- P2
 - PMC1 I/O (64 signals)
 - Two USB 2.0
 - VME64x & 2eSST
 - Four RS232/422/485
 - Two 10/100/1000BaseT Ethernet
 - Two GPIO

OTHER FEATURES

- Real Time Clock with battery backup
- Real time counters
- Watchdog

EXPANSION MODULE

- Site 1 supports PMC or XMC (PCI-X/PCIe x8)
- Site 2 supports PMC or XMC (PCI-X/PCIe x4) or alternatively supports a mounting kit for a 2.5" SATA HDD or SSD

FRONT PANEL CONNECTIVITY

- One GigE (RJ45)
- One RS232/422/485 console (Micro-BD9)
- One USB 2.0 (Type A)

REAR TRANSITION MODULE

- MVME8110-RTM or VXS1-RTM1
 - Two USB 2.0 ports (Type A)
 - Two RS232/422/485 ports (Micro-DB9)
 - One port is switchable between a console and standard COM port
 - Two RS232/422/485 ports (internal headers)
 - Two 10/100/1000BASE-T Ethernet ports (RJ45)
 - One PMC Interface Module (PIM) site
 - 2 GPIO to (internal header)
 - Reset switch

POWER REQUIREMENTS

- ENP1: 38 W idle, 42 W typical, 54 W max

Software and Firmware Specifications

BOOT

- UBoot binary and source code

BOARD SUPPORT PACKAGES

- Wind River VxWorks
- Linux

MTBF

Estimate to be provided when available.

All Modules

ENVIRONMENTAL

Ruggedization Level	ENP1
Cooling Method:	Forced Air
Operating Temperature:	0 °C to +55 °C
Storage Temperature:	-40 °C to +85 °C
Vibration Sine: (10min/axis)	2G, 5 - 500 Hz
Vibration Random: (1hr/axis)	.002 g ² /Hz, 15 to 2000 Hz ¹
Shock:	20 g/11 mS
Humidity:	to 95% RH
Conformal Coating:	No

Note 1: Flat 15-1000 Hz, -6 db/octave 1000 Hz – 2000 Hz [MIL-STD 810F Figure 514.5C-17]

ELECTROMAGNETIC COMPATIBILITY (EMC)

- Artesyn board products are tested in a representative system to the following standards:
 - U.S.: FCC Part 15, Subpart B, Class A (non-residential)
 - Canada: ICES-003, Class A (non-residential)
 - CE Mark per European EMC Directive 2004/108/EC with Amendments; Emissions: EN55022 Class A; Immunity: EN55024
 - KCC Mark (ENP1) - in process

DOCUMENTATION

- Installation and Use Manuals
- Programmers Reference Manual
- Release Notes
- OS Release Notes and User Guide

Ordering Information	
Part Number	Description
Boards	
MVME8110-01E	P5010 1.2GHz, 2GB DDR3, 2PMC/XMC, ENP1, IEEE
MVME8110-01S	P5010 1.2GHz, 2GB DDR3, 2PMC/XMC, ENP1, SCANBE
Rear Transition Modules	
MVME8110-RTM	RTM FOR MVME8110 or MVME8100, without P0, IEEE
Accessories	
MVME8100-HDMTKIT4	MVME8100/8110 hard drive mounting kit for ENP1

SOLUTION SERVICES

Artesyn Embedded Technologies provides a portfolio of solution services optimized to meet your needs throughout the product lifecycle. Design services help speed time-to-market. Deployment services include global 24x7 technical support. Renewal services enable product longevity and technology refresh.

PICMG, AdvancedTCA, ATCA and the AdvancedTCA logo are trademarks of PICMG. Service Availability is a proprietary trademark used under license. Intel and Xeon are trademarks of Intel Corporation or its subsidiaries in the United States and other countries. Microsoft and Windows are registered trademarks of Microsoft Corporation. All other product or service names are the property of their respective owners.

This document identifies products, their specifications, and their characteristics, which may be suitable for certain applications. It does not constitute an offer to sell or a commitment of present or future availability, and should not be relied upon to state the terms and conditions, including warranties and disclaimers thereof, on which Artesyn Embedded Technologies may sell products. A prospective buyer should exercise its own independent judgment to confirm the suitability of the products for particular applications. Artesyn reserves the right to make changes, without notice, to any products or information herein which will, in its sole discretion, improve reliability, function, or design. Artesyn does not assume any liability arising out of the application or use of any product or circuit described herein; neither does it convey any license under its patent or other intellectual property rights or under others. This disclaimer extends to any prospective buyer, and it includes Artesyn's licensee, licensee's transferees, and licensee's customers and users. Availability of some of the products and services described herein may be restricted in some locations.

WORLDWIDE OFFICES

Tempe, AZ U.S.A.	+1 888 412 7832	Shanghai, China	+86 21 3395 0289
Munich, Germany	+49 89 9608 2552	Tokyo, Japan	+81 3 5403 2730
Hong Kong	+852 2176 3540	Seoul, Korea	+82 2 3483 1500

