

COMX-CORE-2000 Series

COM Express® Type 6 Module

Embedded Computing for
Business-Critical Continuity™

PRELIMINARY DATA SHEET

COM Express modules are designed to provide embedded PC processing functionality for high performance applications

- Intel® 2nd generation Core™ i7 processors at up to 2.4 GHz
- Extended temperature variant
- Up to 16GB DDR3 memory
- Gigabit Ethernet, SATA and USB ports
- Dual graphics outputs
- Multiple PCI Express lanes for high speed expansion

The COMX-CORE-2000 series of COM Express® modules are based on the 2nd generation Intel® Core™ i7 mobile processors for high performance applications. These new processors are especially suitable for embedded applications due to their improved performance/ power ratio and small form factor. This type of COM Express module provides embedded PC functionality and is designed to be plugged onto a custom carrier board to create an application-specific solution. Already widely adopted in the industrial automation and medical markets, this latest COM Express module incorporates new functionality for improved security and management.

The COMX-CORE-2000 series uses the latest generation Unified Extensible Firmware Interface (UEFI) BIOS. This manages the interaction between the low-level hardware interfaces and the OS level in a clean and efficient way that is expected to provide superior reliability, especially considering the flexibility for user I/O and option ROM on custom baseboards.

COMX-CORE-2000 modules have a wide range of interfaces to connect to standard peripherals directly or to carrier mounted I/O. These include LCD and CRT displays, SATA, PCI Express devices, USB and Gigabit Ethernet networks. Obviously some of the target applications are in locations not well suited to physical disk support and so in addition to SATA disk support, COMX-CORE modules also have the capability to use and boot from an optional eUSB flash disk, available up to 16Gb capacity.

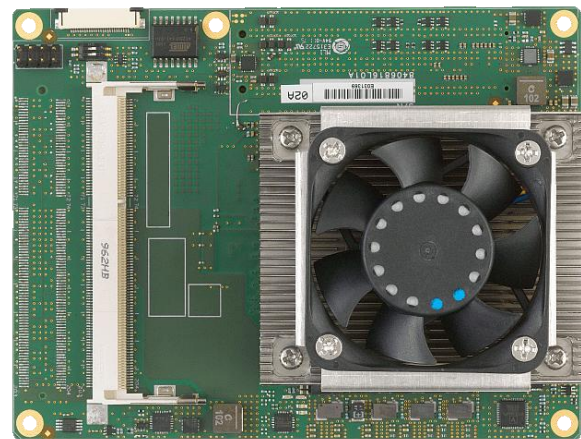

Block Diagram

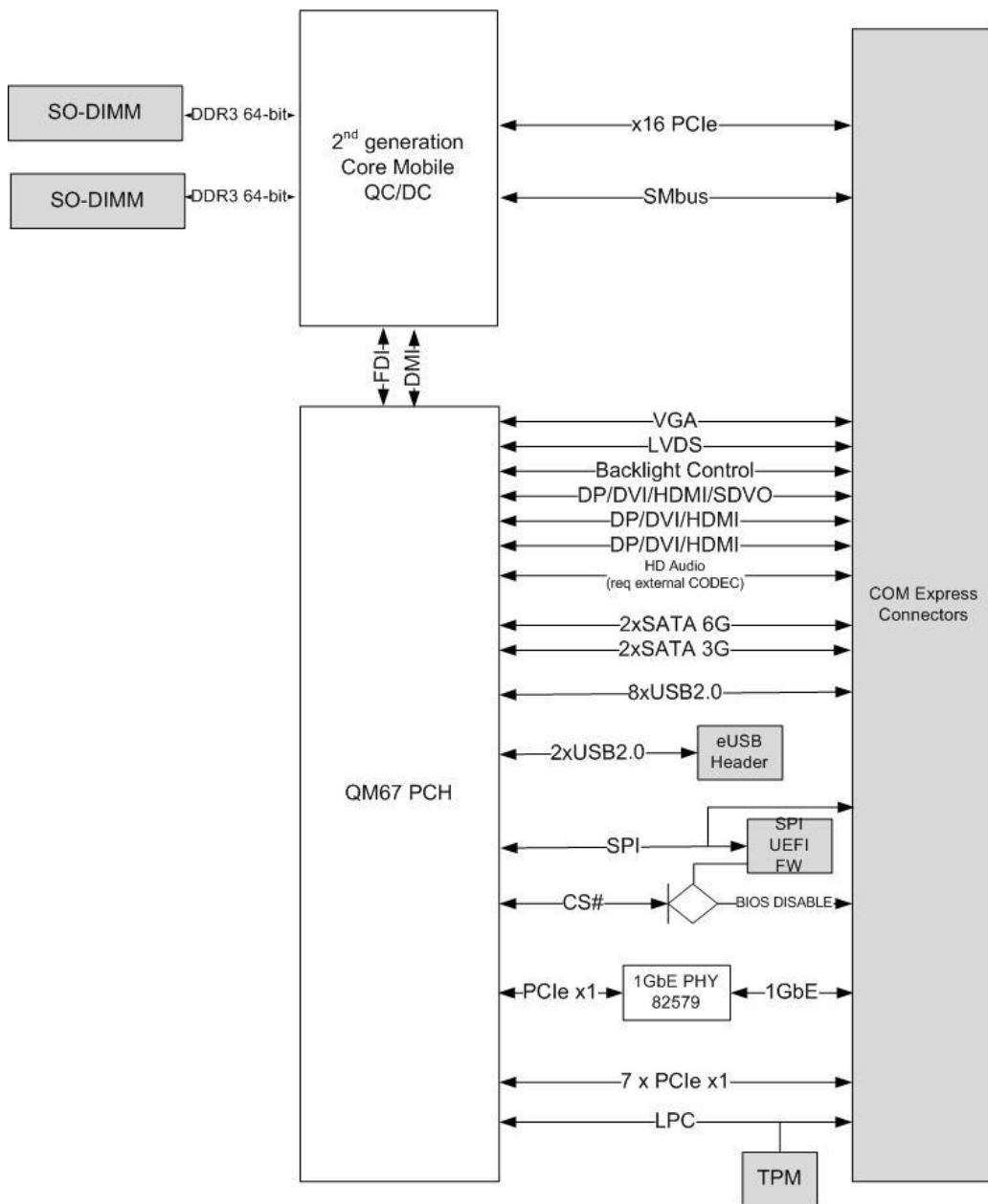

COMX-CORE-2000 Series Features

PROCESSOR

- Intel® 2nd generation Core i7-2715QE quad-core 2.4 GHz
- Intel® 2nd generation Core i7-2610UE dual-core 1.5 GHz

CHIPSET

- Intel® mobile QM67 Express

MEMORY

- Two DDR3 800/1066 64-bit SO-DIMM sockets. Maximum memory capacity is 16GB

FORM FACTOR AND TYPE

- COM Express® R2.0 compliant
- Basic size (125 mm x 95 mm)
- Type 6 pinout

I/O VIA COM EXPRESS CONNECTORS

- One PCI Express x16 from processor
- Seven PCI Express x1 from PCH
- One Gigabit Ethernet (Intel 82579)
- LVDS
- VGA
- DisplayPort/HDMI/SDVO
- High definition audio (requires external codec)
- Two SATA 6G and two SATA 3G
- Eight USB 2.0
- LPC

COMPLIANCE AND SAFETY INFORMATION

- EMC and Safety
 - Class B (FCC, VCCI, CE, KC, AS/NZ)
- UL, CSA, Ctick
- Designed to comply to IEC60601

Firmware and Operating System Support

BIOS

- UEFI BIOS

OS COMPATIBILITY

- Microsoft® Windows XP
- Microsoft® Windows 7
- Fedora Linux

Package Contents

- One COM Express module
- Drivers CD

Ordering Information

Part Number	Description
COMX-CORE-2715	Basic size type 6 COM Express module with i7-2715QE quad core processor. 0 to 60°C operating temperature
COMX-CORE-2610-ET	Basic size type 6 COM Express module with i7-2610UE dual core processor. -20 to 70°C operating temperature
Accessories	
COMX-CAR-612	COM Express R2.0 development carrier for COMX-CORE-2000
COMX-CORE-800-HSP	Heatspreader for COMX-CORE-2000
COMX-CORE-800-HTSNK	Active heatsink for COMX-CORE-2000

SOLUTION SERVICES

Emerson Network Power provides a portfolio of solution services optimized to meet your needs throughout the product lifecycle. Design services help speed time-to-market. Deployment services include global 24x7 technical support. Renewal services enable product longevity and technology refresh.

Intel and Xeon are trademarks of Intel Corporation or its subsidiaries in the United States and other countries. Microsoft and Windows are registered trademarks of Microsoft Corporation. All other product or service names are the property of their respective owners.

This document identifies products, their specifications, and their characteristics, which may be suitable for certain applications. It does not constitute an offer to sell or a commitment of present or future availability, and should not be relied upon to state the terms and conditions, including warranties and disclaimers thereof, on which Emerson Network Power may sell products. A prospective buyer should exercise its own independent judgment to confirm the suitability of the products for particular applications. Emerson Network Power reserves the right to make changes, without notice, to any products or information herein which will, in its sole discretion, improve reliability, function, or design. Emerson Network Power does not assume any liability arising out of the application or use of any product or circuit described herein; neither does it convey any license under its patent or other intellectual property rights or under others. This disclaimer extends to any prospective buyer, and it includes Emerson Network Power's licensee, licensee's transferees, and licensee's customers and users. Availability of some of the products and services described herein may be restricted in some locations.

Emerson Network Power.
The global leader in enabling
Business-Critical Continuity™.

■ AC Power

■ Connectivity

■ DC Power

■ **Embedded Computing**

■ Embedded Power

■ Infrastructure Management & Monitoring

■ Outside Plant

■ Power Switching & Controls

■ Precision Cooling

■ Racks & Integrated Cabinets

■ Services

■ Surge Protection

Emerson Network Power

Offices: Tempe, AZ U.S.A. 1 800 759 1107 or +1 602 438 5720

Paris, France +33 1 60 92 31 20 • Munich, Germany +49 89 9608 2333 • Tel Aviv, Israel +972 9 9560361

Hong Kong +852 2176 3540 • Shanghai, China +8610 8563 1122 • Tokyo, Japan +81 3 5403 2730 • Seoul, Korea +82 2 3483 1500

EmersonNetworkPower.com/EmbeddedComputing

Emerson, Business-Critical Continuity and Emerson Network Power are trademarks of Emerson Electric Co. or one of its affiliated companies. ©2009 Emerson Electric Co.