

ATCA-F140

40G AdvancedTCA Switch Blade

■ Embedded Computing for
Business-Critical Continuity™

PRELIMINARY DATA SHEET

High bandwidth, 40G switch blade design for AdvancedTCA platforms

- PICMG® 3.0 compliant base interface switch
- PICMG 3.1, Option 1, 9 fabric interface switch (1G/10G)
- PICMG 3.1 R2 for 40G fabric support (future)
- Single AMC site
- Optional SATA HDD
- Optional Telecom clocking support
- Integrated software package
- Designed for NEBS/ETSI compliance

The ATCA-F140 from Emerson Network Power is a high performance, high bandwidth 40G switch blade for AdvancedTCA® platforms. This product is perfect for the most bandwidth intensive telecom applications such as LTE and 4G network build-out in general. Along with the maximum ATCA fabric bandwidth available, the ATCA-F140 includes several features to maximize ATCA platform cost effectiveness.

Combining several ATCA® functions within a single blade design allows end users to maximize billable slots with revenue-generating application blades. This is accomplished with a combination of factory build options as well as several field options. Optional functions include telecom clock generation and distribution, SATA based hard drive devices (HDDs) and an AdvancedMC™ (AMC) site for general processing and/or packet processing functions.

Several applications can be easily mapped to the flexible configuration options provided by the ATCA-F140. One common application is to combine the ATCA base and fabric interface switching function with the System Management function. This is done using a processor AMC and an on-board SATA HDD. Another application scenario is to combine the base and fabric interface switching function with a 1G packet processing AMC. Selecting different configuration options also allows for maximum external I/O via 1G, 10G and 40G Ethernet interfaces from the front panel and/or optional RTM. Many more configurations are possible, all fully controlled using a software utility.

Basic Blade Services (BBS) software is a fully integrated and verified software package available for the ATCA-F140. It includes carrier-grade Linux operating system (OS), all required device drivers and SRstackware switch software.

A powerful on-board service processor executes all switch functions, blade setup and hardware platform management functions independent of any processor AMC and/or SATA HDD installed. This allows full, 100% utilization of the AMC based processor for end-user applications.

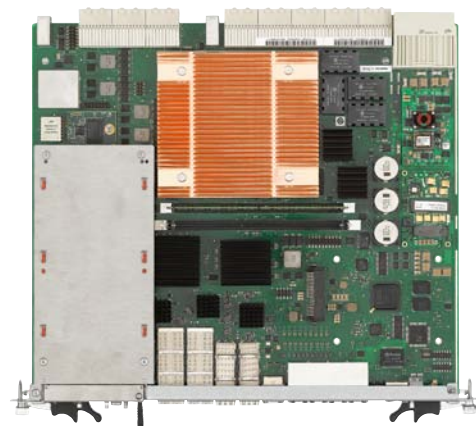

AdvancedTCA®

EMERSON™
Network Power

ATCA-F140 Block Diagram

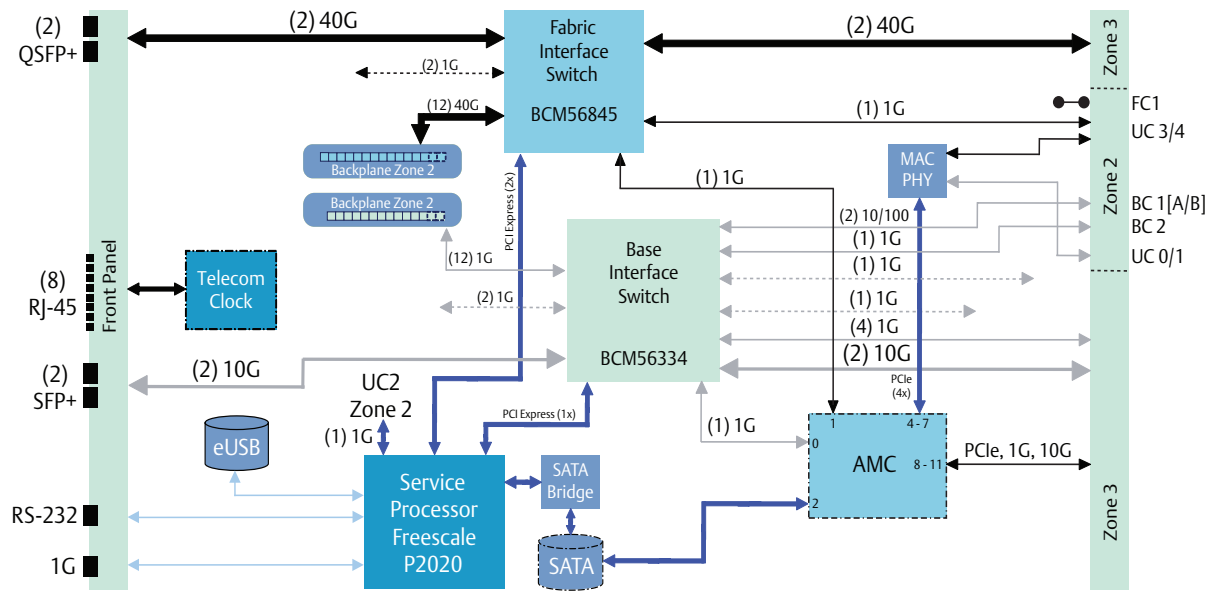

Hardware

SERVICE PROCESSOR

- Freescale QorIQ™ P2020, dual-core processor, 1.0 GHz

MEMORY

- Up to 4GB ECC-protected SDRAM, via (2) DDR3 memory DIMMs
 - ▲ Factory default – 2GB
- 64MB boot flash (NOR), dual-bank architecture
- 2GB application flash (NAND), via eUSB
- 16MB CPU reset-persistent memory

COUNTERS/TIMERS

- Four (4) 32-bit programmable timer/counters
- Watchdog timer

BASE AND FABRIC INTERFACES

- Dual star configuration
- PICMG 3.0 base interface switching – Gigabit Ethernet (1.0Gbps)
- PICMG 3.1, Option 1, 9 fabric interface – Gigabit Ethernet (1.0Gbps, 10Gbps)
- 4x 10GBASE-KR fabric interface (40G)
- 40GBASE-KR4 fabric interface (40G)

AMC SITE

- Single AMC slot
- Mid-size AMC (AMC.0, AMC.1, AMC.2 and AMC.3 compliant)

STORAGE BAY

- Single hard drive device (HDD) bay
- Direct mount installation
- Standard SATA interface
 - ▲ Default configuration – P2020 service processor via SATA bridge
 - ▲ Optional configuration – connection to AMC, port 2

FRONT PANEL INTERFACES

- Service processor
 - ▲ 1G Ethernet, RJ-45
 - ▲ RS-232 serial, RJ-45
- Base interface
 - ▲ (2) 10G Ethernet, SFPP
- Fabric interface
 - ▲ (2) 40G Ethernet, QSFP

- Telecom Clock interfaces
 - ▲ (5) Inter-shelf interfaces, RJ-45
 - ▲ (1) Master/Slave interface, RJ-45
 - ▲ (2) BITS/SSU interfaces, RJ-45

REAR TRANSITION MODULE (RTM)

RTM-ATCA-F140

- Base interface
 - ▲ (2) 10G Ethernet, SFPP
 - ▲ (4) 1G Ethernet, SFP
- Fabric interface
 - ▲ (4) 10G Ethernet, SFPP
 - ▲ (1) 40G Ethernet, QSFP

BLADE DIMENSIONS

- 8U form factor, 280 mm x 322.5 mm, single slot

RELEVANT STANDARDS

- PICMG 3.0 (form factor, IPMI, base interface, hot swap, RTM)
- PICMG 3.1, Options 1 and 9
- PICMG 3.1 R2 (future)
- Telcordia GR-1244-CORE [5] (if equipped with Telecom Clock function)
- ANSI T1.101 [9] (if equipped with Telecom Clock function)

POWER CHARACTERISTICS

- Dual redundant -48V rails
- Input range: -40 VDC to -72 VDC
- Power draw nominal/maximum: TBD/TBD Watts

OPERATING ENVIRONMENT

- Operating temperature range: -5 °C to +55 °C @ 90% non-condensing humidity
- Storage temperature range: -40 °C to +70 °C @ 95% relative humidity

Telecom Clock Characteristics (if equipped)

TELECOM CLOCK CHIP

- Semtech Tpsync ACS9510

MODES OF OPERATION

- T0 normal operation: During normal (locked) operation, the T0 clocks shall be locked to the selected T1, T2 or T3 reference source.
- T0 free-run operation: During free-running mode, the T0 clocks shall be derived from the local oscillator.
- T0 hold-over operation: During holdover mode, the T0 clocks shall be based on the most recent valid

reference available.

- T4 normal operation: During normal (locked) operation, the T4 clocks shall be locked to the selected T1 or T2 reference source.
- T4 hold-over and free-run operation: During free-running and holdover mode, the T4 clock shall be suppressed.

TIMING REFERENCE

- Traditional signal-based reference as defined by ITU-T G812 & G813 [3 & 4]
- Telcordia GR-1244-CORE [5]
- IEEE 1588, v2 (future)

PERFORMANCE

- Stratum 3 and Stratum 3E versions are available.

Basic Blade Services Software

The ATCA-F140 can be configured with an optional software package that, when combined with the hardware, creates a fully integrated and verified switch blade environment. Basic Blade Services (BBS) software combines all the essential features required for a fully functional switch infrastructure for ATCA platforms; allowing customers to focus on revenue-generating software development projects. Below is a summary of BBS software. For additional detail, please refer to the Basic Blade Services software datasheet.

Blade-Specific Firmware (FW) for the IPMC function as required by PICMG 3.0 as well as uboot for the service processor. This firmware contains all the required device initialization functions and is architected for redundancy via dual-bank flash hardware support on the ATCA-F140.

Operating System (OS) software specifically compiled for the ATCA-F140 with all required device drivers and provided in binary form for simple out-of-the-box operation. The ATCA-F140 operating system is a Carrier Grade Linux (CGL) distribution based on Wind River PNE 3.0.

Hardware Platform Management (HPM) is a software abstraction layer for the Intelligent Platform Management Interface (IPMI) function. This is provided to help facilitate blade-level management without requiring in-depth knowledge of IPMI functionality that can sometimes be cumbersome to work with. A set of commands is provided by the HPM package for retrieving and modifying field replaceable unit (FRU) data, reading and controlling the status of IPMI controlled LEDs, relaying E-key events, and communicating local slot information. An HPM command can also encapsulate a sequence of lower-level IPMI commands, for example, to upgrade the firmware or read all FRU data.

Link Health Check (LHC) is a connectivity-based high availability function integrated into BBS software. It continually monitors Layer 2 connectivity on the Base and Fabric networks within an ATCA platform. Within the ATCA-F140, LHC acts as a “proctor” function and communicates with all “responder” functions integrated in payload blade LHC packages. Any connectivity faults detected by LHC are reported via standard Syslog functionality.

Firmware Upgrade Facility (FUF) provides a common way to upgrade firmware on all Emerson ATCA blades, regardless of hardware implementations. The FUF upgrades the uboot firmware as well as the Intelligent Platform Management Controller (IPMC) firmware. The FUF currently consists of a firmware upgrade Command Line Utility (CLU), flash device drivers, and specially prepared firmware recovery image files.

Hardware Platform Interface (HPI) provides an abstracted interface to manage platform-level hardware elements outside the scope of IPMI control. HPI is a Service Availability Forum™ (SA Forum) defined specification. Emerson’s implementation of HPI also allows for “multi-shelf” management support. Specifically for the ATCA-F140, HPI controls and monitors inventory data associated with platform resources, sensors, watchdogs, system event logs and hardware events.

SRstackware is a comprehensive software solution for Emerson ATCA switch and payload blades. SRstackware is fully integrated into BBS software and provides switch chip initialization and configuration, management as well as a full suite of L2 and L3 protocols. General networking functions including support for IPv4, IPv6, SNMP and L2 bridging is supported. L2 protocol support includes, but is not limited to, STP, RSTP, MSTP, flow control, broadcast storm recovery, VLANs, link aggregation, CoS and VLAN stacking. L3 protocol support includes IGMP, OSPF, VRRP, RIP and RIPng.

Basic Blade Services Architectural Block Diagram

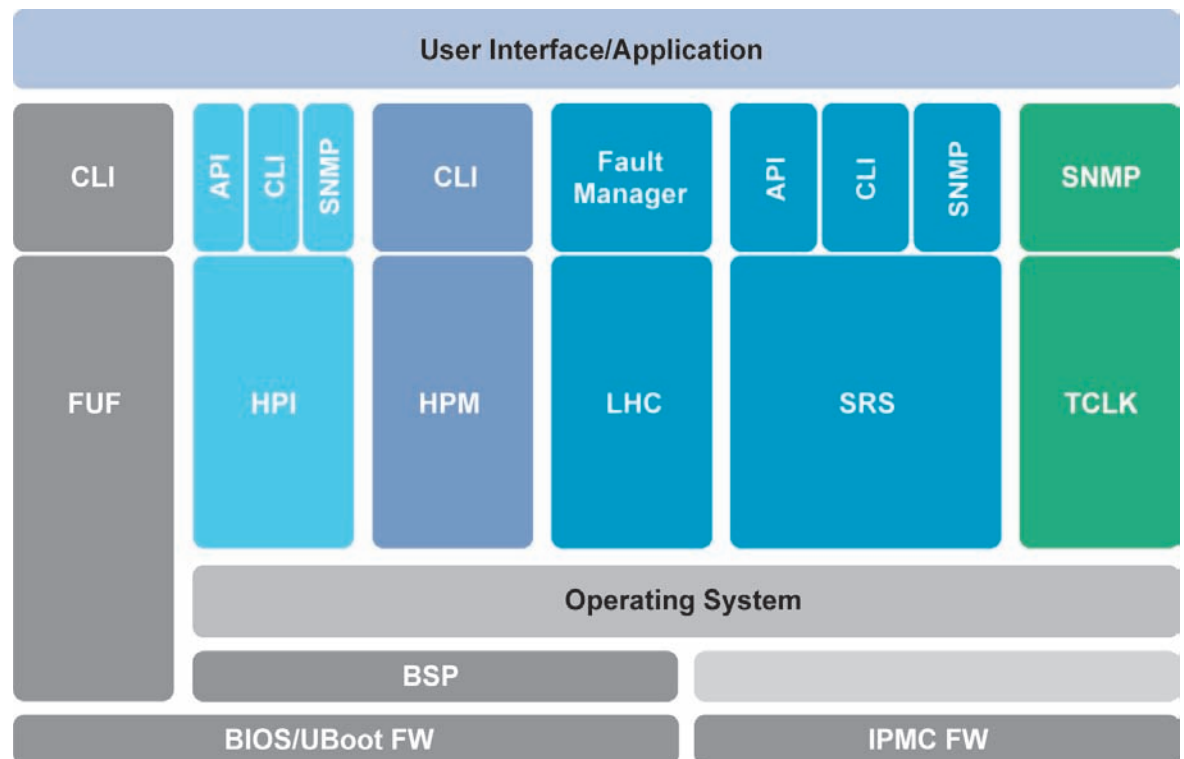

Regulatory Compliance	
Item	Description
Designed to comply with NEBS	Telcordia GR-63-CORE, NEBS Physical Protection, Level 3
	Telcordia GR-1089-CORE, Electromagnetic Compatibility and Electrical Safety – Generic Criteria for Network Telecommunications Equipment. Level 3, Equipment Type 2
Designed to comply with ETSI	ETSI Storage, ETS 300 019-2-1, Class 1.2 equipment, Weatherprotected, not Temperature Controlled Storage Locations
	ETSI Transportation, ETS 300 019-1-2, Class 2.3 equipment, Public Transportation
	ETSI Operation, ETS 300 019-1-3, Class 3.1(E) equipment, Partly Temperature Controlled Locations
	ETSI EN 300-132-2 Environmental Engineering (EE); Power supply interface at the input to telecommunications equipment; Part 2: Operated by direct current (dc)
	ETS-300-753, Equipment Engineering (EE); Acoustic noise emitted by telecommunications equipment
EMC	ETSI EN 300 386 Electromagnetic compatibility and Radio spectrum Matters (ERM); telecommunication network equipment; ElectroMagnetic Compatibility (EMC) requirements, Telecommunication equipment room (attended)
	FCC 47 CFR Part 15 Subpart B (US), Class A
	ECISPR 22, Limits and Methods of Measurement of Radio Disturbance Characteristics of Information Technology Equipment
	AS/NZS CISPR 22 (Australia/New Zealand), Limits and Methods of Measurement of Radio Disturbance Characteristics of Information Technology Equipment
	VCCI Class A (Japan), Voluntary Control Council for Interference by Information Technology Equipment
	Industry Canada ICES-003 Class A
Safety	Compliance to UL/CSA 60950-1, EN 60950-1 and IEC 60950-1 CB Scheme. Marked with U.S. NRTL, Canadian Safety and CE Mark.
RoHS/WEEE compliance	DIRECTIVE 2002/95/EC OF THE EUROPEAN PARLIAMENT AND OF THE COUNCIL on the restriction of the use of certain hazardous substances in electrical and electronic equipment (RoHS)
	DIRECTIVE 2002/96/EC OF THE EUROPEAN PARLIAMENT AND OF THE COUNCIL on waste electrical and electronic equipment (WEEE)
CE Conformity	Directive 2004/108/EC, Directive 2006/95/EC

Ordering Information	
Marketing Number	Description
Switch Blade Products	
ATCA-F140	ATCA system controller & switch blade with 40G fabric
ATCA-F140-TCLK3	ATCA system controller & switch blade with 40G fabric & telecom clock S3
Optional Switch Blade Products	
RTM-ATCA-F140	RTM for the ATCA-F140 with SFPP & SFP sockets
SFP-MM-SX-LC	1G single form factor (SFP) module - 850NM, SX, LC connector
SFP-CO-RJ-45	1G copper single form factor (SFP) module - RJ-45 connector
SFPP-MM-SR-LC	10G single form factor plus (SFPP) module - 850NM, SR, LC connector
SFPP-SM-LR-LC	10G single form factor plus (SFPP) module - 1310NM, LR, LC connector
SFPP-CO-RJ-45-2M	10G copper single form factor plus (SFPP) modules with molded cable (2M)
CABLE-OPT-F102-5M	Optical cable for multi-mode, SFP and SFPP connections (5M)
CABLE-COP-QSFPP-3M	40G QSFP+direct attach, molded cable for ATCA-F140 (3M)
QSFP-40G-SR4-MODULE	40G QSFP+ module for the ATCA-F140 - 40GBASE-SR4
CABLE-OPT-QSFPP-5M	40G QSFP+ optical cable for ATCA-F140 (5M)
CABLE-B-OPT-QSFPP-5M	40G QSFP+ optical cable break-out for ATCA-F140 (5M)
PRAMC-7211	AMC CPU blade w/Intel® Core™2 Duo 64GB @ 1.5 GHz, 2G DDR2 and mid-size
SA-BBS-721X	PrAMC-721x, BBS only, binary RPMS, PNE 2.x, CD
SA-BBS-WR2X-721X	PrAMC-721x, BBS binary RPMS. Eval kernel + runtime, PNE LE 2.x, CD
HDD-80G-SATA	Direct mount 80GB HDD for ATCA-F125 & ATCA-F140 - Extreme temp - SATA interface













SOLUTION SERVICES

Emerson Network Power provides a portfolio of solution services optimized to meet your needs throughout the product lifecycle. Design services help speed time-to-market. Deployment services include global 24x7 technical support. Renewal services enable product longevity and technology refresh.

PICMG, AdvancedTCA and AdvancedMC are trademarks of PICMG. Intel and Core are trademarks of Intel Corporation or its subsidiaries in the U.S. and other countries. Service Availability is a proprietary trademark used under license. All other product or service names are the property of their respective owners.

This document identifies products, their specifications, and their characteristics, which may be suitable for certain applications. It does not constitute an offer to sell or a commitment of present or future availability, and should not be relied upon to state the terms and conditions, including warranties and disclaimers thereof, on which Emerson Network Power may sell products. A prospective buyer should exercise its own independent judgment to confirm the suitability of the products for particular applications. Emerson Network Power reserves the right to make changes, without notice, to any products or information herein which will, in its sole discretion, improve reliability, function, or design. Emerson Network Power does not assume any liability arising out of the application or use of any product or circuit described herein; neither does it convey any license under its patent or other intellectual property rights or under others. This disclaimer extends to any prospective buyer, and it includes Emerson Network Power's licensee, licensee's transferees, and licensee's customers and users. Availability of some of the products and services described herein may be restricted in some locations.

Emerson Network Power.
The global leader in enabling
Business-Critical Continuity™.

-  AC Power
-  Embedded Power
-  Precision Cooling
-  Connectivity
-  Infrastructure Management & Monitoring
-  Racks & Integrated Cabinets
-  DC Power
-  Outside Plant
-  Services
-  Embedded Computing
-  Power Switching & Controls
-  Surge Protection

Emerson Network Power

Offices: Tempe, AZ U.S.A. 1 800 759 1107 or +1 602 438 5720
Paris, France +33 1 60 92 31 20 • Munich, Germany +49 89 9608 2333 • Tel Aviv, Israel +972 9 9560361
Hong Kong +852 2176 3540 • Shanghai, China +86 21 3395 0289 • Tokyo, Japan +81 3 5403 2730 • Seoul, Korea +82 2 3483 1500

EmersonNetworkPower.com/EmbeddedComputing

Emerson, Business-Critical Continuity and Emerson Network Power are trademarks of Emerson Electric Co. or one of its affiliated companies. ©2011 Emerson Electric Co.

ATCAF140-D3 01/11