

HIGH-AVAILABILITY MILITARY SWITCH-ROUTER

POWERFUL, OPEN AND FLEXIBLE COTS L2/L3 MULTILAYER MANAGED SWITCH-ROUTER WITH EDGE-COMPUTING CAPABILITIES



High-availability for Mission-critical Applications

HSR, PRP and TSN-CB for zero-delay recovery time in case of network failure

Full IEEE 1588 (PTP) Support

Nano-second range time accuracy even over redundant networking paths

SW and HW Microservices Supported

Cutting Edge multi-core CPU with FPGA to support user applications

Security-by-Design

Multi-layered security to protect the system against heterogeneous threats.
Cybersecurity certified

MIL-STD

1st class military enclosure
MIL-STD-461G
MIL-STD-810G

Multiple Media Type

Copper and fiber based connections support

Overview

The MIL-SWITCH-ROUTER is a Military COTS family of Managed 1/10G Ethernet Switch, Router and Edge Computing equipment focused on Ground and Airborne applications.

It supports up-to **20x 1G copper and up-to 6x 1/10G Fiber Optic ports**. An additional 1x 1G RJ45 Ethernet service port is accessible in a specific connector. The support for different media type and its distribution in the MIL-DTL-38999 connectors allow implementing complete and cost-effective network infrastructures.

The heart of this versatile equipment is a Xilinx Ultrascale+ MPSoC device that includes **6x ARM CPUs, 1x GPU and a latest generation FPGA in the same Integrated Circuit**. The switching and routing functions are accelerated by hardware in the FPGA section. This flexibility allows offering different **Switching & Routing & Computing personalities** according to the requirements of the program.

As an example, this flexibility allows offering equipment versions **supporting HSR, (M)RSTP or Deterministic Ethernet** with the same hardware. Fiber Optic rings combining these protocols are feasible thanks to the inter-switch coordination mechanism developed by SoC-e.

The military certifications of the equipment include environmental, mechanical and electromagnetic aspects according to **MIL-STD-810G and MIL-STD-810F**. Additionally, the equipment has obtained the **cybersecurity certification Common Criteria-LINCE** by the Spanish Cryptologic National Center.

MIL-SWITCH-ROUTER supports accurate time distribution via PTP and NTP. If GNSS sourced Grand Master operation is required, a GNSS/PTP/NTP Grand Master operation and the support for 2x additional Fiber Optic ports can be included.

Main Features

- 20x 10/100/1000-BaseT copper ports
- Up-to 6x 1/10GbE SR/LR/BX Fiber Optic ports
- General purpose service Ethernet port
- Latest Generation ARM, GPU and FPGA Hardware
- High-availability Seamless Redundancy (HSR)
- Parallel Redundancy Protocol (PRP)
- Precision Time Protocol (PTP)
- Auxiliary RS232 Console Port
- Edge-computing capabilities for user defined applications
- General Purpose, PPS and IRIGb Input and Output available on auxiliary connector
- Optional Grand Master/Time Server/Clock bridging capabilities
- Sealed Military Enclosure Cold Plate Cooled
- Dual redundant MIL-STD-704 AC/DC Power Supply
- Tested and Certified by Independent Official Laboratories per MIL-STD-810G & MIL-STD-461G & Lince Common-Criteria Cybersecurity



Key Benefits

Reliability

With MIL-SWITCH-ROUTER the mission reliability is enhanced thanks to the application of interoperable high-availability and deterministic Ethernet solutions. Depending on the selected *Personality* the equipment provides support for zero-delay recovery time HSR and PRP protocols, TSN-CB or other combinations with (M)RSTP.

High-availability Seamless Redundancy (HSR, IEC 62439-3-Clause 5) provides redundancy by sending packets in both directions through a ring network. A simple HSR network consists in Doubly Attached Bridging Nodes, each having two Ethernet ports. An HSR node sends the same frame over both ports, therefore even in fault scenario where the fiber optic is broken, no frame lost is ensured and the communication among all the nodes continues.

Parallel Redundancy Protocol (PRP, IEC 62439-3-Clause 4) implements redundancy in the nodes rather than in the network. Especially adapted nodes (Dual Attached Nodes – DANs) are connected to two independent and standard Ethernet networks (LAN A and LAN B) and send the same frames over both networks. The PRP operative ensures the reception of all the information even if one of the networks fails.

Time-Sensitive Networking (TSN, IEEE 802.1Q extended to support real-time traffic) is the new generation Ethernet that provides determinism to enforce advanced QoS policies. It supports in the same network hard real-time, reserved and best-effort traffic. The seamless redundancy at frame level is supported thanks to IEEE 802.1CB TSN standard. This functionality is available on MIL-TSN-SWITCH-ROUTER from Relyum.



Synchronization

The key benefit of implementing Precise Time Protocol (PTP) or IEEE 1588-2008 is a similar accuracy level of synchronization that provides a GPS receiver, in a device connected to an Ethernet network. Being able of sharing the same nanosecond-range time reference in all the embedded systems of the vehicle it is feasible ensuring sensor synchronization and even time-triggered operations.

MIL-SWITCH-ROUTER implements a comprehensive solution for PTP. Apart from supporting the Transparent Clock operation required for any 1588-aware switch, this equipment supports PTP over HSR/PRP, Ordinary and Boundary Clock and PTP/NTP bridging. This means that it is feasible configuring the MIL-SWITCH-ROUTER as the PTP Masters or Slaves in the vehicle.

- Master, Slave, Boundary and Bridging Clock capabilities
- GNSS/PTP/NTP timing source support
- Embedded GPS receiver to provide GNSS reference for accurate timing, clocking, and positioning
- NTP and PTP (IEEE 1588) master and slave modes supported
- Autonomous operation via Disciplined Oscillators for when GPS-less operation is required is available

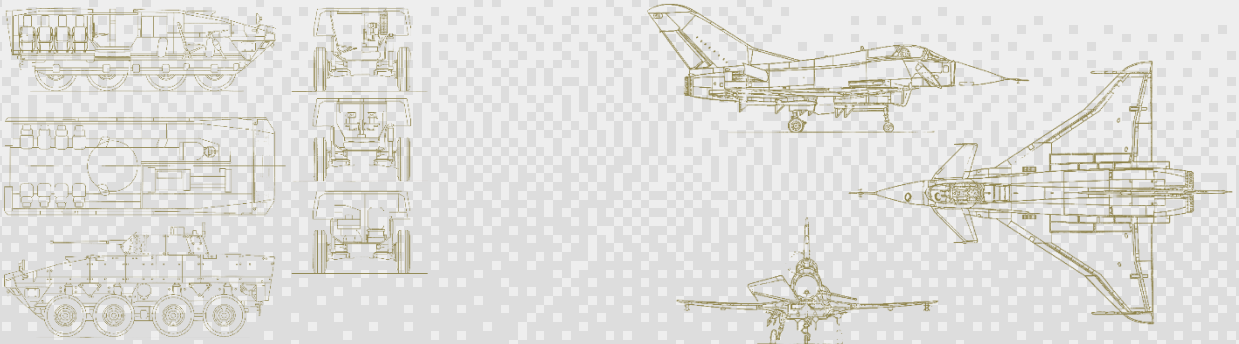

Security is a must for military systems susceptible to be used in field. MIL-SWITCH-ROUTER is a smart switch-router designed following "security-by-design" approach to achieve the highest levels of protection. A multi-layered analysis and protection is required to cover security threats that may arise at integrated circuit, embedded device, network, vehicle and infrastructure levels.



MIL-SWITCH-ROUTER is LINCE-Common Criteria certified by JSEC third-party laboratory and by the Spanish Cryptographic National Center.

The equipment supports hardware root-of-trust, firmware encryption, authentication and signature features. Additional security related circuits, like TPM among others, allow secure equipment enrolments, certificates management and security real-time supervision against potential physical attacks.

General security features

- Anti-Tampering capability and embedded crypto-engines
- Secure-Boot capability
- Security sensors
- Trusted Platform Module (TPM) 2.0
- Advanced System Supervisor (ASS)
- Zeroing

Networking related security features

- 802.1X authentication
- Hardware protection against Denial-of-Service
- Selective ports disabling capability
- Unsecure ports disabling capability
- Management IP address restriction capability
- Port Mirroring

Integrated security services

- Firewall
- VPN

Equipment secure management

- Secure CLI - SSH
- Secure SNMP - SNMP v3
- Certificates management
- User roles
- Secure equipment image update

Logging and audit

- General logs and active connections monitoring
- Logs of BITE

Secure and interoperable event messages interchange via Syslog v3

- Syslog security extension
- Syslog Common Event Format (CEF) extension for SIEM interoperability
- Keys and certificates for TLS

Support for Security Information and Event Management (SIEM)

Support for wire-speed security and group Security Key management

Edge-Computing

The raw information collected from the heterogeneous sensors and actuators populated in the new military equipment demands distributed edge-computing capabilities in order to reduce and to enrich the data information finally communicated in the backbone network.

In order to offer a COTS solution able to support this fog-computing approach, MIL-SWITCH-ROUTER integrates in a long term supply single integrated circuit an impressive computation capacity: 4x ARM Cortex-A53 and 2x Dual-core ARM Cortex-R5 CPUs, 1x Mali™-400 MP2 GPU and high-end FPGA to support the advanced networking features offered by this equipment. The RAM memory on-board is a high-speed DDR4 memory while non-volatile memory demands are satisfied through a high-capacity flash device.

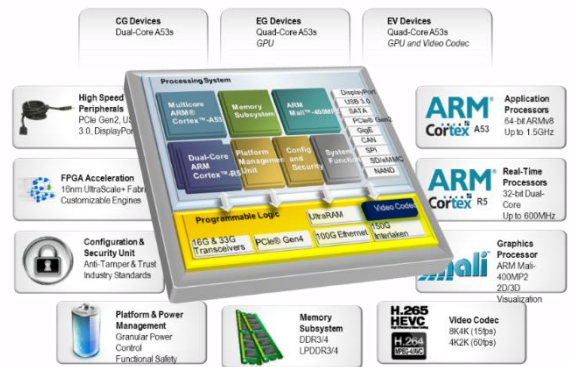

Victory/NGVA/stanag 4754: Official and worldwide partnership between SoC-e and RTI Inc. to support DDS based projects

Multiple Media Type Support



Both Copper and Fiber Based Connections supported under 1/10GbE SR/LR/BX Fiber Optic Links standards.

MIL-STD

Tested and Certified by Independent Official Laboratories:

- MIL-STD-810G & MIL-STD-461G. IP68.
- Connectors MIL-DTL-38999
- AC/DC MIL-STD-704F
- Acoustic MIL-STD-1474D
- HF Communications MIL-STD-110F
- Vehicle MIL-STD-1275D
- Lince - Common Criteria - Cybersecurity Certification

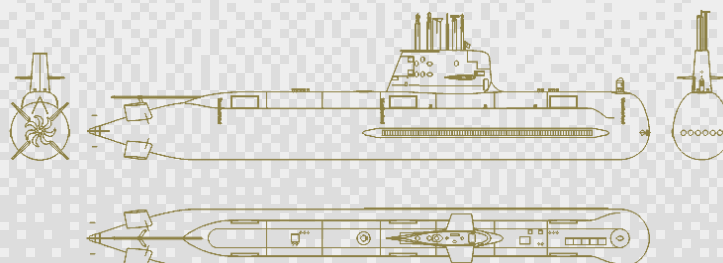

Front Panel I/O

The MIL-SWITCH-ROUTER implements standard MIL-38999 series connectors that are ideally suited for the full spectrum of military applications.

Connectors J1-J5 support four 10/100/1000BaseT Ethernet links each (A-B-C-D) x 5. Connectors OP1 and OP2 support two fiber optical links each (1-2-3-4).

A panel circular RJ45 rugged connector has been selected for the service Ethernet port.

A miscellaneous connector groups RS232 serial lines, GPIO signals, PPS and IRIGb timing outputs, Temperature Supervisory Unit standby control, system reset and battleshort functions.

A 5-pin power connector provides input voltage to the Switch.



General Networking Functionalities

(applicable to all personalities)

Equipment Telecontrol

- Protocol SNMP V1/V2/V3

Layer 2 General Functionalities

- IEEE 802.3-2000
- Automatic MAC address learning and aging
- Static MAC Table
- Port-Based Virtual LANs (VLANs)
- IEEE 802.1Q for VLAN tagging
- IEEE 802.1Q for VLAN based Ethernet priorities
- Ethertype based switching
- IEEE 802.1p for Class of Service (CoS)
- IEEE 802.1ab for Link Layer Discovery Protocol (LLDP)
- Priority Modes: PCP (802.1p), Ethertype (Up to 16)
- Broadcast protection configurable via register
- Layer 2 multicast filtering
- Jumbo frame support
- IEEE 1588 StateLess TC (Transparent Clock
- 802.1s/w for (M)RSTP (Rapid Spanning Tree Protocol)

Synchronization

- IEEE 1588v2 PTP "Precision Time Protocol" profiles with E2E mode and P2P mode of operation
- IEEE 1588v2 PTP "Precision Time Protocol" over HSR & PRP
- Grand Master capability
- S(NTP) & Client

Equipment Management and Monitoring

- HTTPS Web GUI interface with secure firmware/bitstream update
- Graphic representation of Network status (HSR DANs & VDANs)
- Statistics independent per port
- SNMP RFC 1157/RFC
- DHCP (Client and Server)
- System Syslog
- MIB support
- Console port

Layer 3 General Functionalities

- IPv4/IPv6
- Multicast IP Routing
- IGMP Snooping
- DSCP TOS
- Dynamic Routing: BGPv4, BGPv6, OSPFv2, RIPv2

Specific Functionalities

(applicable to each personalities)

High-availability Ethernet

- IEC 62439-3 Clause 4 PRP "Parallel Redundancy Protocol"
- IEC 62439-3 Clause 5 HSR "High-availability Seamless Redundancy"

Time-Sensitive Networking (TSN) *

* This functionality is available only MIL-TSN-SWITCH(-ROUTER) equipment from Relyum.

Wire-speed cryptographic

- In-line hardware implemented crypto-processor to cipher or decipher traffic

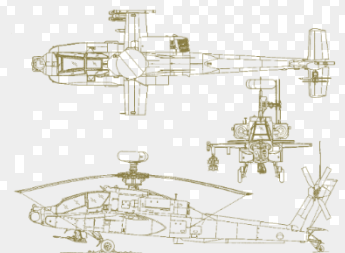

Functionalities per *Personality*

(examples)

Personalities (FPGA & Software)	Main networking functionalities	Redundancy type
HSR-10GSTP-L3	<ul style="list-style-type: none"> • RING 1: 2x Layer 2 low-latency hardware switched HSR ports (1x ring) or 2x PRP Dual Port Connection in the 1G Fiber Optic port • RING 2: 2x Layer 2 low-latency hardware switched MSTP/RSTP ports (1x ring) in the 10G Fiber Optic port • Inter-switch coordination mechanism to allow HSR/(M)RSTP rings interconnection • 20x Managed Ethernet ports with high-throughput Layer 2/3 HW switching and packet filtering (IGMP snooping) • 1x GbE Ethernet Service Port Layer 2 (switching) and Layer 3 (static and dynamic routing) capabilities 	<p>Redundancy:</p> <ul style="list-style-type: none"> • IEC 62439-3 Clause 4 PRP "Parallel Redundancy Protocol" • IEC 62439-3 Clause 5 HSR "High availability Seamless Redundancy" • 802.1s/w for (M)RSTP (Rapid Spanning Tree Protocol)
10GSTP-10GSTP-L3	<ul style="list-style-type: none"> • RING 1: Layer 2 low-latency hardware switched MSTP/RSTP ports (1x ring) in the 10G Fiber Optic ports (MIL200410G only) • RING 2: Layer 2 low-latency hardware switched MSTP/RSTP ports (1x ring) in the 10G Fiber Optic ports (MIL200410G only) • Inter-switch coordination mechanism to allow HSR/(M)RSTP rings interconnection • 20x Managed Ethernet ports with high-throughput Layer 2/3 HW switching and packet filtering (IGMP snooping) • 1x GbE Ethernet Service Port Layer 2 (switching) and Layer 3 (static and dynamic routing) capabilities 	<p>Redundancy:</p> <ul style="list-style-type: none"> • 802.1s/w for (M)RSTP (Rapid Spanning Tree Protocol)

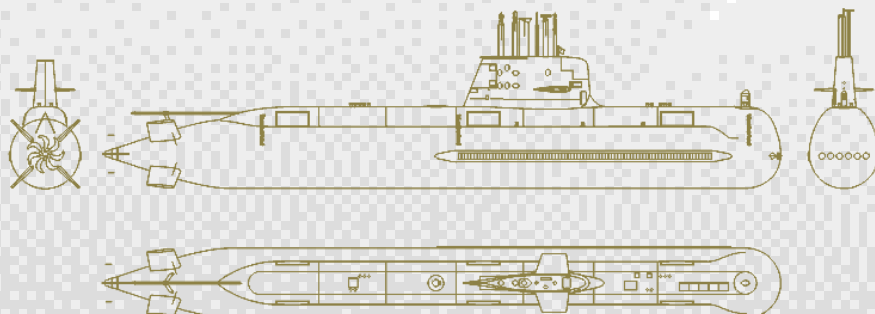

Functionalities per *Personality* (examples)

Personalities (FPGA & Software)	Main networking functionalities	Redundancy type
2xHSR-L3	<ul style="list-style-type: none"> RING 1: 2x Layer 2 low-latency hardware switched HSR ports (1x ring) or 2x PRP Dual Port Connection in the 1G Fiber Optic port RING 2: 2x 2x Layer 2 low-latency hardware switched HSR ports (1x ring) or 2x PRP Dual Port Connection in the 1G Fiber Optic port Inter-switch coordination mechanism to allow HSR/(M)RSTP rings interconnection 20x Managed Ethernet ports with high-throughput Layer 2/3 HW switching and packet filtering (IGMP snooping) 1x GbE Ethernet Service Port Layer 2 (switching) and Layer 3 (static and dynamic routing) capabilities 	<p>Redundancy:</p> <ul style="list-style-type: none"> IEC 62439-3 Clause 4 PRP "Parallel Redundancy Protocol" IEC 62439-3 Clause 5 HSR "High availability Seamless Redundancy" 802.1s/w for (M)RSTP (Rapid Spanning Tree Protocol)

Block diagram of 2xHSR-L3 Personality (Example)

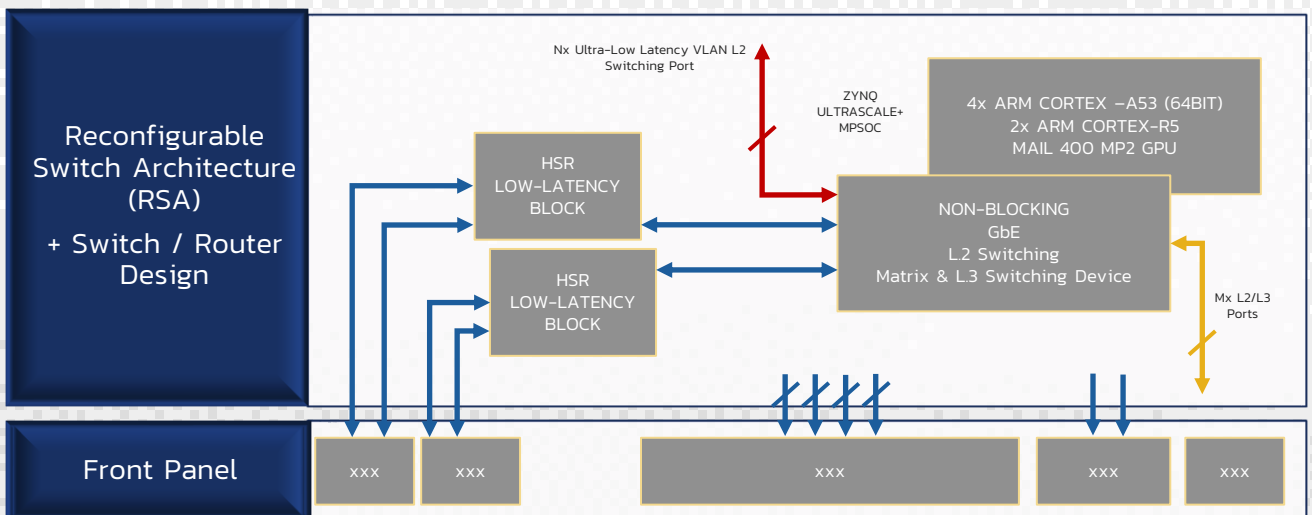

Military Certificates and Environmental

ENVIRONMENTAL/MECHANICAL

- Shock: MIL-STD-810G Functional Shock, Method 516.6
- Vibration: MIL-STD-810G General Vibration, Method 514.6
- Acceleration: MIL-STD-810G Constant Acceleration, Method 513.6
- Humidity: MIL-STD-810F Humidity Test Certificate Method 507.4
- Fungus: MIL-STD-810F Fungus Test Certificate DO160F, Section 13, Category F Method 508.5
- Salt Fog: MIL-STD-810F Test Certificate Method 509.3
- Ingress Protection IP66: (IEC 60529 / UNE 20324) Drip Test Certificate EN 60529
- Operating Temperature -40°C to 71°C : MIL-STD-810G High Temperature Procedure III, Climatic Category A1- Hot Dry. Method 501.5
- Storage Temperature -40°C to 85°C : MIL-STD-810G Method 501.6/502.6

ELECTROMAGNETIC COMPATIBILITY

- Radiated Magnetic Field 10Hz-100KHz: MIL-STD-461G, RE101
- Radiated Magnetic Field 10KHz-18 GHz: MIL-STD-461G, RE102
- Conducted Emissions, Power Leads 30Hz-10KHz: MIL-STD-461G, CE101
- Power Leads 10KHz-10MHz: MIL-STD-461G Conducted Emissions, CE102
- Radiated Susceptibility, Magnetic Field 30Hz-100KHz: MIL-STD-461G, RS101
- Electric Field 2MHz, 18GHz: MIL-STD-461G Radiated Susceptibility, RS103
- Power Leads 30Hz, 150KHz: MIL-STD-461G Conducted Susceptibility, CS101
- Conducted Immunity Bulk cable injection 10KHz-200 MHz: MIL-STD-461G, CS114
- Conducted Susceptibility Bulk cable injection: MIL-STD-461G, impulse excitation, CS115
- Conducted Susceptibility, Damped sinusoidal: MIL-STD-461G Transient Cables & Power Leads 10KHz, 100 MHz, CS116

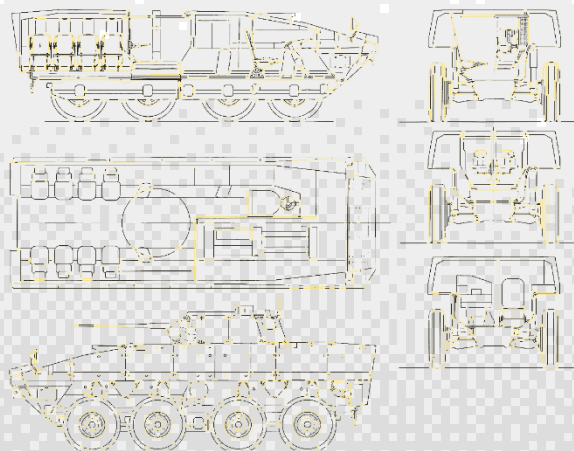

Military PSU Input Options

The MIL-SWITCH-ROUTER Switch power supply unit is extremely versatile in order to cover the full range of system applications regardless of the available end platform primary (main) and secondary power voltage.

The three integrated high-performance PSU blocks incorporate a range of features that are only available in latest generation advanced military systems.

When Switch reliability is mission critical and faults are not tolerated, the 'PLUS' dual redundant PSU version ensures low stress load sharing for the twin DC/DC converters and mitigates the risk of an output power failure.

A wide variety of single or redundant AC/DC power input combinations are supported as standard to guarantee flawless operation in worst case scenarios.

Version	Diagram	Configuration	Output Power	Description
STANDARD VERSION		DC INPUT SINGLE PSU	A-50W B-75W	1. - 1SDC Suited for UAVs, light armored vehicles and mobile ground weapon or communication systems equipped with DC batteries.
		AC INPUT SINGLE PSU	B-75W	2. - 1SAC Ideal for Navy and Aircraft platforms fitted with 115 or 220VAC generators. This configuration is also suitable for laboratory and maintenance facilities.
		REDUNDANCY VIA TWO DC BATTERIES WITH COMMON GND SINGLE PSU	A-50W B-75W	3. - 2SDC Ideal for military UAVs, mobile ground weapon systems and heavy armored vehicles fitting multiple DC battery banks that share a common ground.
PLUS VERSION		INDEPENDENT AC INPUTS DUAL REDUNDANT PSU	D-150W	4. - 2DRAC Suited for mission critical AC applications aboard Navy and Aircraft platforms that require dual redundancy, greater reliability and extended MTBF.
		INDEPENDENT AC + DC INPUT DUAL REDUNDANT PSU	D-150W	5. - 2DRACDC Ideal for multi-role mission critical applications that require both AC and DC dual redundancy, greater reliability and extended MTBF.
		INDEPENDENT DC INPUTS DUAL REDUNDANT PSU	C-100W D-150W	6. - 2DRDC For mission critical UAVs, ground systems and heavy armored vehicles that require full dual DC redundancy, greater reliability and extended MTBF.
		SINGLE DC BATTERY INPUT DUAL REDUNDANT PSU	A-100W D-150W	7. - 1DRDC For single battery mission critical UAVs, mobile weapon systems & light armored vehicles requiring dual redundancy, greater reliability & extended MTBF.
		SINGLE AC INPUT SINGLE PSU	D-150W	8. - 1DRAC For single AC generator mission critical UAVs, Navy and Aircraft platforms requiring dual redundancy, greater reliability and extended MTBF.

Military PSU Input Options

CODE	SWITCH PSU PART NUMBER CONFIGURATION
1	The device is powered by One External AC or DC Source
2	The device is powered by Two External AC or DC Sources
S	A single PSU is fitted in the device (STANDARD Version)
DR	Two (dual redundant) PSUs are fitted in the device (PLUS Version)
115VAC	The input voltage is 115VAC @ 40-880Hz
220VAC	The input voltage is 220VAC @ 40-880Hz
12VDC	The input voltage is 12VDC (9-36VDC @ 50W)
28VDC	The input voltage is 28VDC (9-36VDC @ 50W or 18-36VDC @ 75W)
48VDC	The input voltage is 48VDC (36-75VDC @ 75W)
270VDC	The input voltage is 270VDC (180-375VDC @ 75W)
A-50W	The device fits a single 9-36VDC PSU with 50W output
B-75W	The device fits a single AC or 18-36VDC PSU with 75W output
C-100W	The device fits two redundant 9-36VDC PSUs with 50W+50W output each
D-150W	The device fits two redundant AC or 18-36VDC PSUs with 75W+75W output each

PSU PART NUMBER EXAMPLES

- 1 S 12VDC A-50W
- 1 S 115VAC B-75W
- 1 DR 12VDC C-100W
- 1 DR 28VDC D-150W
- 2 DR 12VDC 12VDC C-100W
- 2 DR 28VDC 220VAC D-150W
- 2 DR 115VAC 220VAC D-150W
- 2 DR 270VDC 48VDC D-150W
- 2 DR 115VAC 12VDC C-100W
- 2 DR 115VAC 28VDC D-150W

Panel LED Indicators

LED	NAME	COLOR	FUNCTION WHEN LED IS ILLUMINATED
ON	PAYLOAD-POWER ON	GREEN	Indicates PSU output DC power is supplied OK and within voltage tolerances
BIT	BUILT-IN-TEST	GREEN	Indicates Switch electronics has passed self test successfully (no fault detected)
PFM	POWER FAIL MONITOR	RED	Indicates Switch external power input voltage falls below the minimum range
TSPW	TEMP SUPERVISOR ON	GREEN	Indicates the Temperature Supervisor Unit is DC powered (TSU is operational)
DTR_1	DATA TRAFFIC RING 1	YELLOW	Flashes when data transfer occurs in Communication Ports assigned to Ring 1
DTR_2	DATA TRAFFIC RING 2	YELLOW	Flashes when data transfer occurs in Communication Ports assigned to Ring 2
TSLO	LOW TEMP FAIL	RED	TSU indicates the system is operating below the Low Temperature threshold
TSHI	HIGH TEMP FAIL	RED	TSU indicates the system is operating above the High Temperature threshold

Eight front panel LED indicators inform the User of system power input/output status, data transfer activity, payload electronics self test pass/fail, operational temperature compliance and standby mode (when the Switch is remotely operated). This information serves during operation in-the-field, maintenance and software development.



System Dimensions

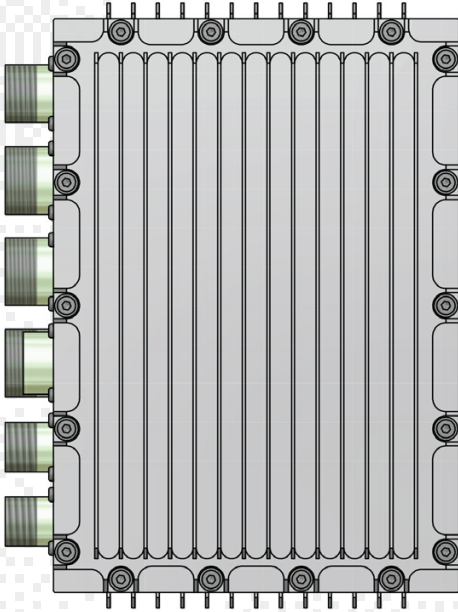

Dimensions (mm)	220 (W) 155 (D) 98 (H)
Weight (Kg)	1,9KG (metalwork) 3,4Kg (with PSU & Payload)
DC Power Input / Consumption	+28VDC, +48VDC, +270VDC / 50W
AC Power Input / Consumption	115VAC 40-800Hz, 220VAC 40-800Hz / 50W
I/O Ports	Ethernet (5x4), Fiber (2x2), RS232 (1), RJ45 (1)
Power & Control	Miscellaneous (13 pin), Power (5 pin)

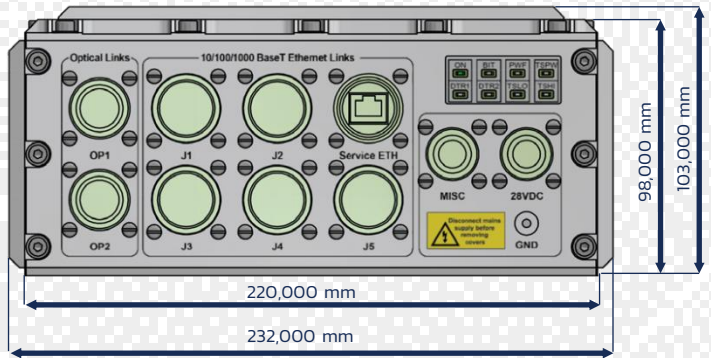
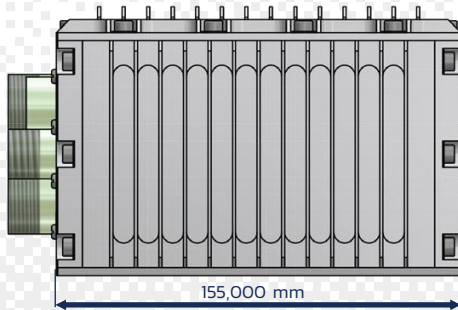

The MIL-SWITCH-ROUTER Switch is mounted as standard via six M4 bottom cover threads that provide secure attachment to the application vehicle base plate. Other mounting options are available upon request. These include side or rear panel fixings, protruding bottom cover legs, front NAS-622 hooks and self-clinching pilot pins, or other.

Cold plate installation is recommended to significantly improve thermal performance and decrease payload Delta-T by approximately 12-15°C. This will double the MTBF of the enclosed electronics.

Ordering Code

MIL-SWITCH-ROUTER equipment is very versatile. The full reconfigurable technology embedded on this product allows custom hardware and software images. All switching capabilities are implemented on the FPGA section of the device. Therefore, the features processed by hardware and their combination with the software processing running on the CPUs and GPU may vary. This feature combination conforms the Personality. MIL-SWITCH-ROUTER interfaces can also be customized depending on the customer's requirements. An example of how to build the unique code to identify the requested equipment is shown below.

MIL20{a}02G{b}0210G{c}GPS{d}-HSR-L3{e}/STD{f}/28VDC{g}/220AC{h}/D-150W{i}/B{j}/E{k}

a: Number of tri-speed copper ports

b: Number of 1G fiber optic ports.

c: Number of 1/10G fiber optic ports. Options:

- 10G Base-SX (Short Range): Only the number of ports are included in the reference
- 10G Base-LR (Long Range): LR acronym is included after the number of ports
- 10G Base-BX(BiDir): BX acronym is included after the number of ports
- 10G Base-BX special ruggedizing: BXR acronym is included after the number of ports

d: Other specific features. Options:

- GPS: GPS Embedded Time Server option with holdover compensation
- GPSDO (Disciplined Oscillator): GPS Embedded Time Server option with extended holdover compensation

e: Personality name

f: Power supply STD or PLUS

g: Primary Input Power

h: Secondary Input Power

i: PSU Output Power

j: Mounting options

k: Color



info@relyum.com

www.relyum.com

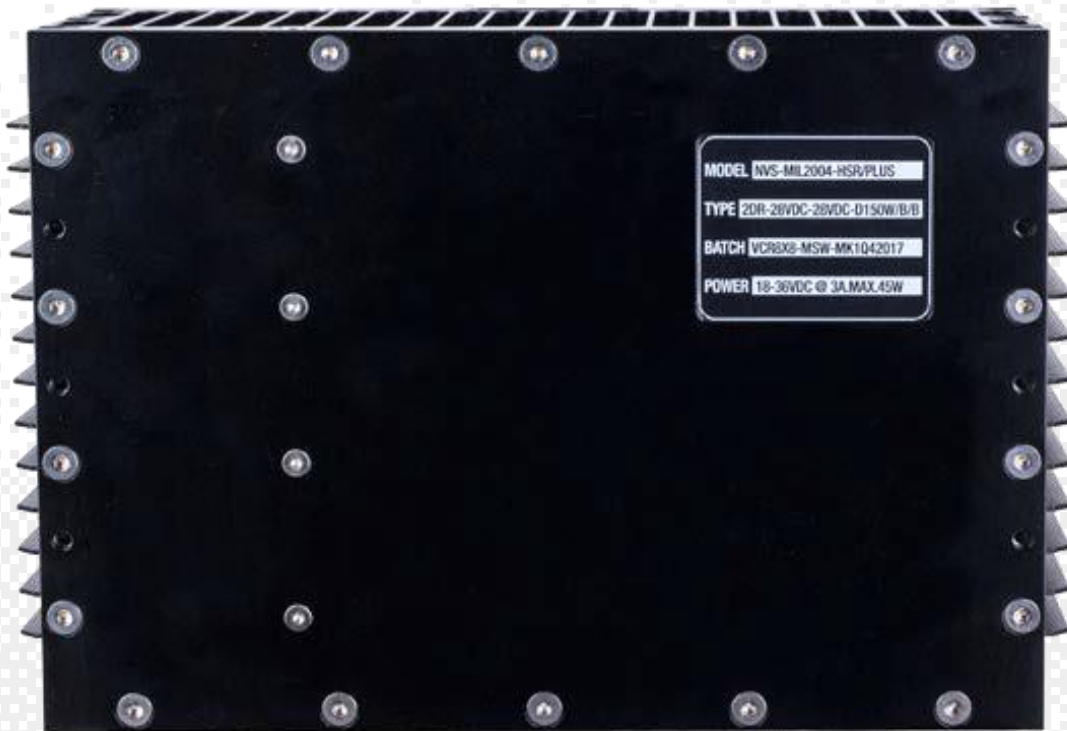

About us

We offer military certified equipment for high-availability and deterministic networking; accurate timing distribution and cybersecurity applications.

RELYUM by SoCe supports the specific requirements of military programs adapting the personality of the FPGA/firmware, board or enclosure.



Certified solutions for military systems integrators:



- Last Generation Combat Systems
- Missile Control Systems
- Tactical Radar and Sonar for the Battlefield
- Military Switch / Router
- Mission Management Systems
- Military GPS
- UAVs
- C4ISR
- Marine Consoles
- Simulators

©2020 System-on-Chip engineering S.L. All rights reserved





System-on-Chip engineering, S.L.

 info@relyum.com
 www.relyum.com



Distributed by:
ECRIN Systems

143, rue Louis Neel
Parc Technologique du Pré Roux
38920 Crolles – FRANCE

Telephone: +33(0) 4 76 92 20 01
eMail: sales@ecrin.com
Web: www.ecrin.com