

## PMC-AX1065/2065/3065 Reconfigurable FPGA Modules with A/D & D/A

- PMC-AX1065: Four A/D, two D/A, 11,520 logic cells
- PMC-AX2065: Four A/D, two D/A, 24,192 logic cells
- PMC-AX3065: Four A/D, two D/A, 32,256 logic cells

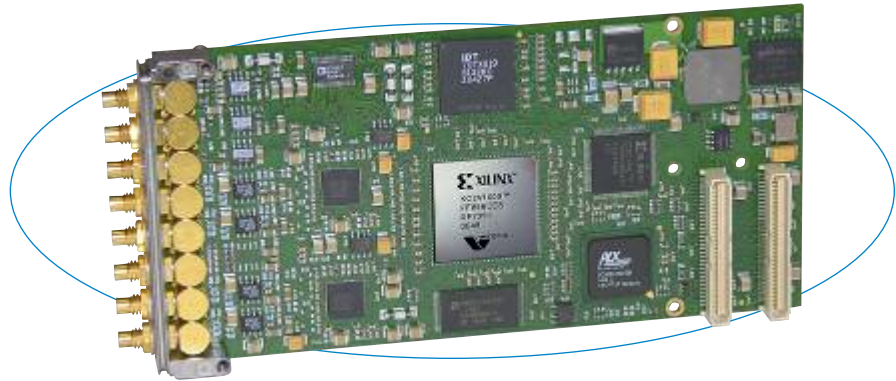

Download your own logic programs and algorithms into the on-board user-configured FPGA to quickly create a custom analog I/O module.

### Description

PMC-AX modules provide users with the capability to implement complex, customized analog I/O solutions. Application-specific logic routines and algorithms can be downloaded into the on-board reconfigurable FPGA to control operation of the I/O channels.

These modules are ideal for high-speed, high-resolution A/D and D/A functions. Typical uses include sonar, sounding systems, satellite downlink controllers, automated test equipment, and simulation instrumentation. Inputs are sampled at 64 MSPS and processed by the FPGA without CPU intervention. For slower sampling, ask about our models with a 20 MSPS A/D converter.

Powerful and versatile, these PMC modules are designed around a reconfigurable Xilinx® Virtex®-II FPGA. A variety of FPGA models can be ordered with a 11,520, 24,192, or 32,256 logic cells. All of these DSP-capable FPGAs feature versatile logic resources, large on-chip memories, and a high-speed interface.

The PCI bus interface is handled by a PLX® PCI 9056 device which provides 32-bit 66MHz bus mastering with dual-channel DMA support.

### Features

- Four 14-bit 64MHz A/D and two 16-bit 900KHz D/A
- Customizable FPGA with up to 3 million system gates (Xilinx Virtex-II XC2V1000, XC2V2000, or XC2V3000)
- FPGA code loads from PCI bus or flash memory
- 256K x 36-bit dual-ported memory
- Supports dual DMA channel data transfer to CPU
- Supports both 5V and 3.3V signalling

### Specifications

#### FPGA

FPGA: Xilinx Virtex-II FPGA

PMC-AX1065: XC2V1000 FPGA with 11,520 logic cells

PMC-AX2065: XC2V2000 FPGA with 24,192 logic cells

PMC-AX3065: XC2V3000 FPGA with 32,256 logic cells

FPGA configuration: Downloadable via PCI bus or from flash memory.

Input/output signals: Four analog inputs, two analog outputs.

Example FPGA program: VHDL provided implements interface to PCI bus IC, interface to dual port SRAM, PLL control, ADC, and DAC control. Program requires user proficiency with Xilinx software tools. See Engineering Design Kit.

#### Analog Input

Input configuration: Four differential channels using four Analog Devices AD9248 A/D converter.

A/D resolution: 14 bits.

Input range:  $\pm 1V$  into a 50 ohm load.

Clock jitter: RMS 1ps max.

SINAD: 62dB

SNR: 63dB

THD: 66dB

SMC: Input connector

Maximum throughput rate:

1 channel (max.): 15.63nS (64MHz).

4 channels (max.): 62.5nS (64MHz) each channel.

A/D trigger: FPGA logic, external source, software.

Data format: Straight binary or binary two's complement.

Bandwidth: 100MHz

Pipeline Delay: 9 clocks

#### Analog Output

Output configuration: Two single-ended channels, individual D/A converters per channel.

D/A resolution: 16 bits.

Output range:  $\pm 5V$ .

Maximum throughput rate:

1 channel: 1.1 $\mu$ S

2 channels: 1.1 $\mu$ S each channel

DAC programming: Via independent channel registers or through shared FIFO.

D/A trigger: FPGA logic, external source, software.

On-board timer: One user-programmable timer for analog output control.

Data format: Straight binary.

Output at reset: 0V.

Output current:  $\pm 40mA$  (maximum).

Short circuit protection: Indefinite at 25°C.

#### Engineering Design Kit

Provides user with basic information required to develop a custom FPGA program. Kit must be ordered with the first purchase of a PMC-AX module. (see [Design Kit](#) for details)

#### PMC Compliance

Conforms to PCI Local Bus Specification, Revision 2.2 and CMC/PMC Specification, P1386.1.

Electrical/Mechanical Interface: Single-Width Module.

PCI bus clock frequency: 66MHz.

32-bit PCI Master: Implemented by PLX PCI 9056 device.

Signaling: 5V and 3.3V compliant.

Interrupts (INTA#): Interrupt A is used to request an interrupt.

#### Environmental

Operating temperature: 0 to 70°C

Storage temperature: -55 to 105°C.

Relative humidity: 5 to 95% non-condensing.

Power: Consult factory. Operates from 3.3V supply.

MTBF: 1,000,000 hrs at 25°C, MIL-HDBK-217F, Notice 2.

All trademarks are the property of their respective owners.

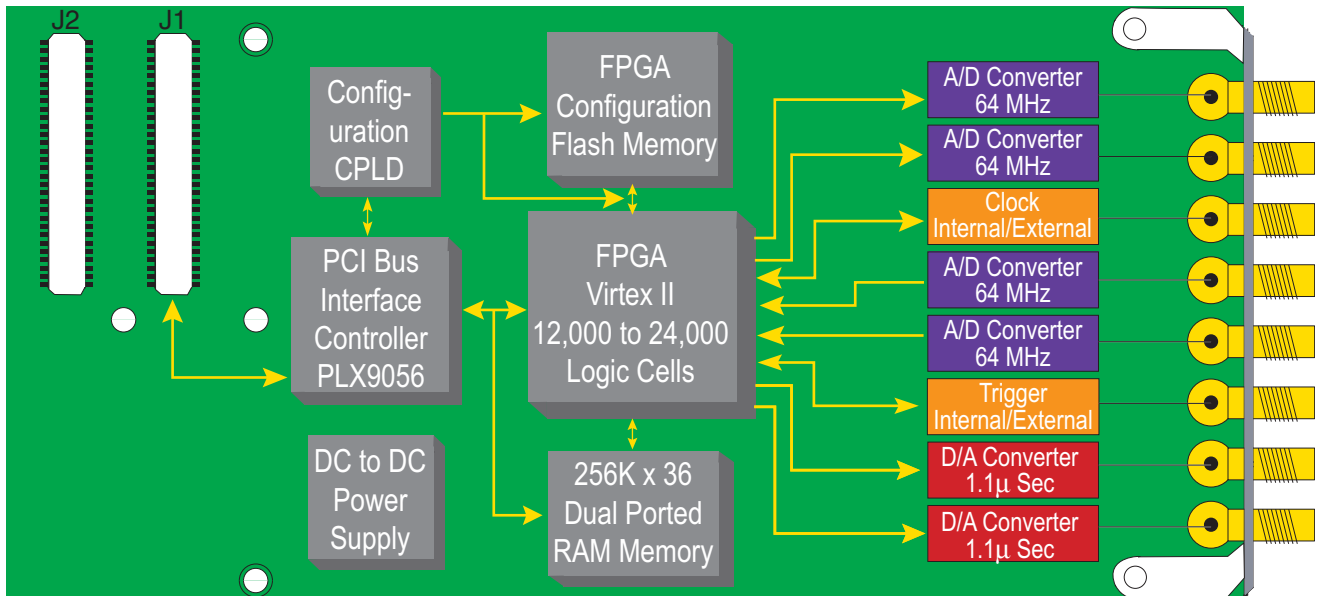

PMC Modules

PMC Modules

## Ordering Information

### PMC Modules

#### PMC-AX1065

Four 64MHz A/D, two 900KHz D/A, 11,520 logic cells

#### PMC-AX2065

Four 64MHz A/D, two 900KHz D/A, 24,192 logic cells

#### PMC-AX3065

Four 64MHz A/D, two 900KHz D/A, 32,256 logic cells

#### PMC-AX-EDK

Engineering Design Kit (one kit required)

### Software (see [software documentation](#) for details)

#### PMCSW-API-VXW

VxWorks™ software support package

#### PCISW-API-QNX

QNX™ software support package

#### PCISW-API-WIN

Windows™ DLL software support

#### PCISW-LINUX

Linux™ support (website download only)

All trademarks are the property of their respective owners.