

AcPC4620CC CompactPCI Non-intelligent PMC Carrier Card (conduction-cooled)

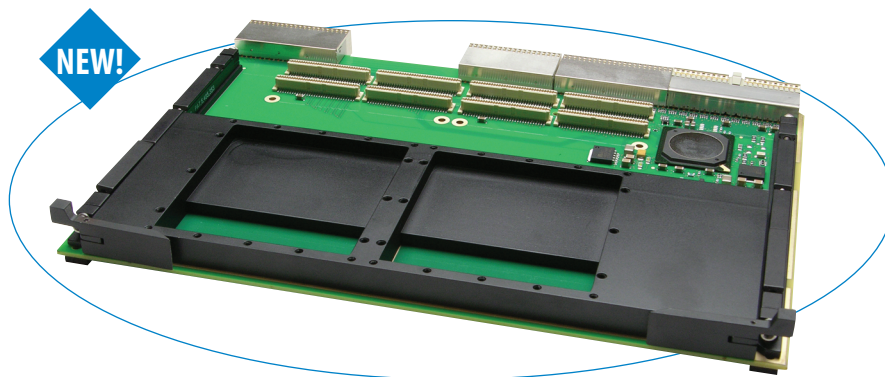

Description

This board provides an easy and low cost solution that enables use of a PMC mezzanine I/O module in a standard 6U CompactPCI computer system. The carrier card acts simply as an adapter to route PCI bus signals to and from the PMC module through the CompactPCI card slot edge connector. All Acromag PMC modules and those from other vendors are supported.

This board uses a PLX Technology PCI6540 transparent PCI/PCI bridge for data transactions from the PCI bus (system host) to two PMC sites. The bridge device provides a 32 or 64-bit PCI interface with 33 or 66MHz bus frequencies.

A heat frame enables conduction cooling in applications where ambient or forced air can't provide adequate cooling. This unit is ideal for airborne systems, deployment in battleground equipment, and other situations with advanced thermal management requirements.

Field I/O signals are routed through the carrier card's rear J3 and J5 connectors

An air-cooled rear transition board, Acromag Model TRANS-C4620, maps the field I/O on the PMC module to the rear of the CompactPCI system.

Features

- 6U CompactPCI card
- Holds two PMC cards
- 32 or 64-bit PCI Interface at 33 or 66 MHz
- Transparent PCI/PCI bridge for data transactions from the PCI bus to PMC module
- Rear connection I/O access
- Supports both 5V and 3.3V signalling
- Conduction-cooled or -40 to 85°C

All trademarks are the property of their respective owners.

This conduction-cooled carrier card interfaces two PMC modules to a CompactPCI computer system.

Specifications

Environmental

Operating temperature: -40 to 85°C or conduction-cooled.

Storage temperature: -55 to 100°C.

Relative humidity: 5-95% non-condensing

American National Standard for 2mm Connector Equipment Practice on Conduction Cooled Euroboards: ANSI/VITA 30.1-2002.

American National Standard for Conduction Cooled PMC: ANSI/VITA 20-2001(R2005).

Power (received from the CompactPCI 3U Back Plane):

3.3V DC (±5%)*: 135mA typical, 150mA max.

5.0V DC (±5%)*: 50mA typical, 70mA max.

±12V DC (±5%)**: Per PMC module.

* With no PMC module installed, ±12V DC not used.

** Max. power 7.5W (total all supplies) per PMC standard.

MTBF: Call factory

Physical: CompactPCI Carrier Cards

Physical configuration: 6U CompactPCI Card
233.35 x 160mm.

Rear CompactPCI connectors: 2mm J1, J2, J3, J5 connectors.

PMC connectors: Eight 1mm connectors.

The conduction-cooled model (AcPC4620CC) uses a conduction-cooled frame with wedge-loks® and thermo bars.

Physical: Transition Module

Physical configuration: Half-length 6U CompactPCI Card
233.35 x 80mm.

Connectors: 2mm RJ2 connector which maps the rear I/O signals to a SCSI-3 connector. This model also uses a standard rear front panel assembly with a SCSI-3 connector cutout.

PMC and CompactPCI bus Compliance

Meets PCI specification version 2.3, CompactPCI specification PICMG 2.3 R1.0, and PMC specification P1386.1.

Meets PCI specification version 2.3, CompactPCI specification PICMG 2.3 R1.0, and PMC specification P1386.1.

Data transfer bus: Slave with 32-bit, 16-bit, and 8-bit data transfer operation.

Interrupts: CompactPCI bus INTA# interrupt signal.

PCI Interface: PLX Technology PCI6540 transparent PCI/PCI bridge for data transactions from the PCI bus (system host) to the PMC site. The bridge device provides a 32-bit 33/66 MHz PCI interface.

Ordering Information

Carrier Cards

AcPC4620CC

CompactPCI bus carrier card for two [PMC modules](#), conduction-cooled

AcPC4620E

CompactPCI bus carrier card for two [PMC modules](#), air-cooled. See Bulletin [8400-489](#).

Accessories (see [accessories documentation](#) for details)

TRANS-C4620: Transition module

5028-432: Shielded cable, SCSI-3 68-pin connector, 2m long.

5025-288: Termination panel, DIN rail-mount, 68 screw terminals, SCSI-3 connector.

ACPC4620CC

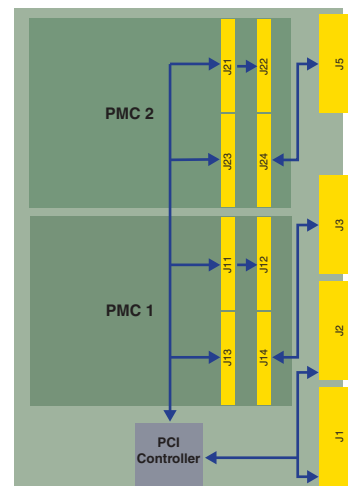

TRANS-C4620 Transition Module

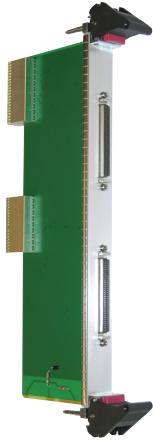

TRANS-C4620 Transition Module

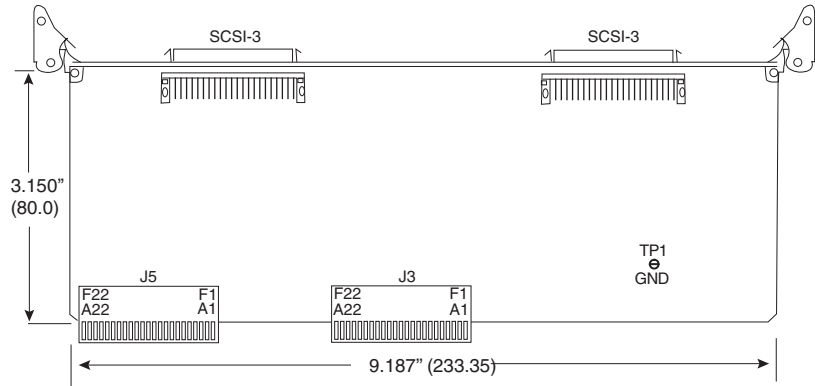

5028-432 SCSI-3 Cable

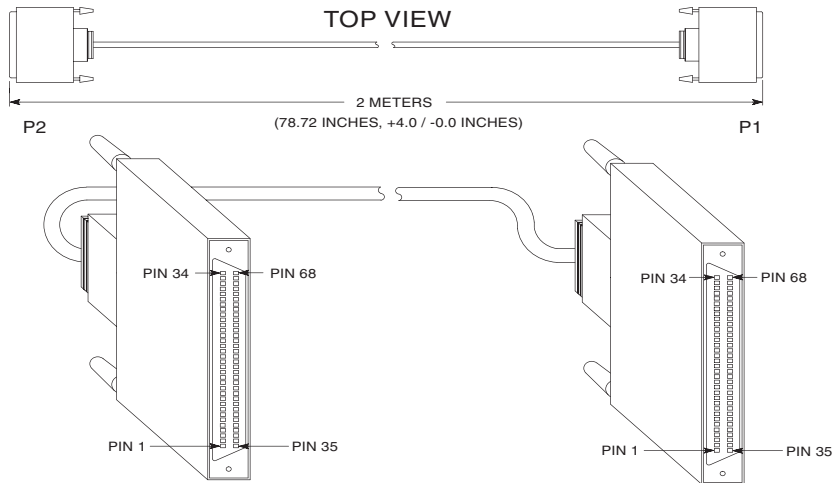
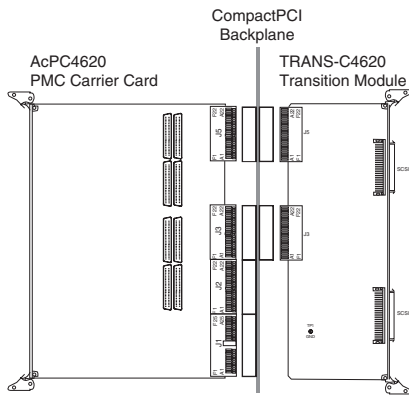

5025-288 Termination Panel

