



Industry Pack Module Carriers

NEW!

APCe8650 PCI Express Carrier Cards for Industry Pack Modules

24 HR STOCK ITEM
7 YEAR WARRANTY

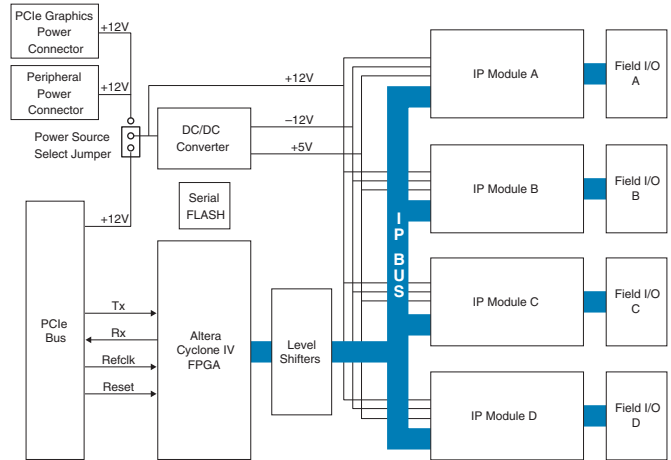

Four Industry Pack mezzanine module slots ♦ Non-Intelligent carrier card ♦ PCIe x1 interface

Description

This board interfaces standard Industry Pack (IP) mezzanine modules to a PCI Express bus on a PC-based computer system.

Four IP module slots give you the freedom to mix a variety of I/O functions (A/D, D/A, digital in, digital out, serial I/O, etc.) on a single board. Or, combine modules of the same type for hundreds of channels on a single card. Either way, the APCA8650 saves your precious card slots and reduces your costs.

Select I/O modules from Acromag's offering of more than forty models or use any third-party ANSIVITA 4 compliant IP modules.

Key Features & Benefits

- Four IP module slots (ANSI/VITA 4 mezzanine) support any combination of I/O functions
- Board resides in memory space
- Supports IP's I/O, ID, INT, and MEM spaces
- Plug-and-play carrier configuration and interrupt support
- Two interrupt channels per IP module
- Supervisory circuit reset generation
- Individually filtered and fused power
- Full IP module register and data access for convenient configuration or control of the I/O modules through software
- Non-volatile ID register to identify carrier
- Software development tools for VxWorks, Linux, and Windows environments



APCe8650 shown with four IP modules inserted.



Acromag offers more than 40 IP modules to perform analog I/O, digital I/O, serial communication, CAN bus, Mil-Std-1553, and configurable FPGA functions.

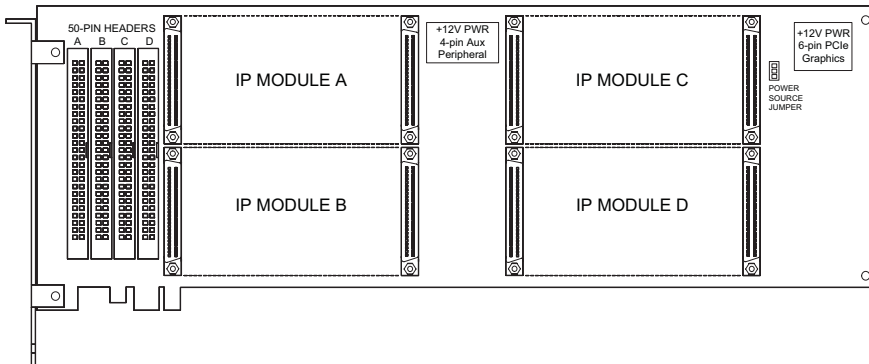

Acromag THE LEADER IN INDUSTRIAL I/O

Tel 248-295-0310 ■ Fax 248-624-9234 ■ solutions@acromag.com ■ www.acromag.com ■ 30765 Wixom Rd, Wixom, MI 48393 USA

Industry Pack Module Carriers

APCe8650 PCI Express Carrier Cards for Industry Pack Modules

Performance Specifications

■ IP Module Compliance

Meets or exceeds all written IP specifications per ANSI/VITA 4-1995 for 8MHz or 32MHz operation. Supports Type I and Type II ID space formats.

Electrical/mechanical interface

Supports four single-size IP modules (A-D).

IP module I/O space, ID space, INT, and MEM space supported.

IP module I/O space

16 and 8-bit; supports 128 byte values per IP module.

IP module ID space

16 and 8-bit; Supports Type I 32 bytes per IP (consecutive even byte addresses) and Type II 32 words per IP via D16 data transfers.

IP module memory space

16 and 8-bit; supports up to 8M bytes of memory space per IP module.

Interrupts

Supports two interrupt requests per IP and interrupt acknowledge cycles via access to IP INT space.

PCI Express Bus Compliance

This device meets or exceeds all written PCI local bus specifications per rev. 1.1 dated March 28, 2005.

System base address

This board operates in PCI memory space. It requires 256 bytes for mapping the PCI configuration registers and 64M bytes for IP module ID, IO, INT and memory space.

Data transfer bus

Slave with 32, 16, and 8-bit data transfer operation. 32-bit read or write accesses implemented as two 16-bit transfers to IP modules.

Interrupts (PCI bus INTA# interrupt signal)

Up to two requests sourced from each IP mapped to INTA#. Interrupt vectors come from IP modules via access to IP module INT space.

■ Physical

Physical Configuration

PCIe x1 lane

Length: 12.283 inches (312.0 mm)

Height: 4.380 inches (111.25 mm)

Board thickness: 0.062 inches (1.59 mm)

Max. height under IP modules: 0.110 in. (2.80 mm).

Connectors

A-D (carrier field I/O): 50-pin male header.

Power: Auxiliary +12V power

■ Environmental

Operating temperature

0 to 70°C (APCe8650)

or -40 to 85°C (APCe8650E model).

Storage temperature

-55 to 100°C.

Relative humidity

5 to 95% non-condensing.

Power

+3.3 Volts (±10%): 190mA, typical; 220mA max.

+12 Volts (±5%): 130mA, typical; 150mA max.

All IP module power is derived from the +12V power supply. +5V, +12V, and -12V are supplied to IP modules. The +12V power can be supplied from the PCIe bus or optionally from either of two auxiliary power connectors.

MTBF

Contact the factory.

Ordering Information

Carrier Card

APCe8650

PCI Express carrier card for Industry Pack modules

APCe8650E

Same as APCA8650 plus extended temperature range

Accessories

5025-550-x

Flat ribbon cable, non-shielded, 50-pin connector at both ends. Specify x = length, in feet (12ft. max.)

5025-551-x

Flat ribbon cable, shielded, 50-pin connector at both ends. Specify x = length, in feet (12ft. max.)

5025-552

Termination panel, DIN rail-mount, 50 screw terminals, 50-pin ribbon cable connector

Industry Pack Modules

See www.acromag.com for more information.

Software Development Tools

See www.acromag.com for more information.

IPSW-API-VXW

VxWorks® software support package

IPSW-API-WIN

Windows® DLL driver software support package

IPSW-LINUX

Linux® support (website download only)

ISO9001
AS9100



Acromag 
THE LEADER IN INDUSTRIAL I/O

Tel 248-295-0310 ■ Fax 248-624-9234 ■ solutions@acromag.com ■ www.acromag.com ■ 30765 Wixom Rd, Wixom, MI 48393 USA