

Features

- Intel® Core™2 Duo processor (up to 2.2 GHz)
- Intel® GME965 / ICH8M chipset
- Dual SODIMM for up to 4 GB DDR2 at 800MHz
- Five PCIe x1, one PCIe x16 graphic (or x8)
- Dual-channel 24-bit LVDS, TV-out
- SATA 3 Gb/s, PATA, Gigabit LAN, USB 2.0

Specifications

Core System

CPU	<p>Socket P type</p> <p>Intel® Core™2 Duo T7500, FSB 800, 2.2 GHz with 4MB L2 cache, 34 W</p> <p>Intel® Celeron® M 550, FSB 533, 2.0 GHz, with 1MB L2 cache 27 W</p> <p>BGA type</p> <p>Intel® Core™2 Duo T7500, FSB 800, 2.2 GHz with 4MB L2 cache, 34 W</p> <p>Intel® Core™2 Duo L7500, FSB 800, LV 1.5 GHz with 4MB L2 cache, 17 W</p> <p>Intel® Core™2 Duo U7500, FSB 533, ULV 1.06 GHz with 2MB L2 cache, 10 W</p>
Memory	Dual stacked SODIMM sockets supporting dual channel memory, up to 4 GB of non-ECC, 533/667 MHz DDR2
Chipset	Intel® GME965 GMCH and ICH8-M
BIOS	AMIBIOS®8 with CMOS backup in 8 Mbit SPI BIOS
Hardware Monitor	Supply voltages and CPU temperature
Watchdog Timer	Programmable timer ranges to generate RESET
Expansion Busses	6 PCI Express x1 (0 – 4 free, 5 occupied by GbE), optional configurable as x4 Graphics PCI Express x16 or PCI Express x8/x4/x1, or SDVO digital video bus 32-bit PCI 2.3 at 33MHz, supporting 6 bus masters LPC, SMBus, I ² C

Video

Chipset	GME965 integrated Mobile Intel® GMA X3100
CRT Interface	Analog CRT support up to 2048 x1536 at 60 Hz, 32-bpp
LVDS Interface	Single / Dual channel 18/24-bit at 25~112 MHz
TV-out	NTSC/PAL up to 1024x768 resolution, HDTV 480p/720p/1080i/1080p modes supported (without Macrovision)

Audio

Chipset	Integrated on Intel® ICH8-M
Audio Codec	HDA codec on carrier

LAN

Chipset	ICH8-M integrated GbE MAC with Intel® 82566 PHY
Interface	10/100/1000 Mbps with Wake-on-LAN and Alert on LAN support

Multi I/O

Chipset	Intel® ICH8-M
IDE (PATA)	Single channel IDE with Ultra ATA 100/66/33 support
SATA	Three ports SATA 3 Gb/s
USB	Up to eight ports USB 2.0

Super I/O

Connected to LPC bus on carrier if needed

TPM

Chipset	Infineon SLB9635TT1.2
Type	TPM 1.2

Power Specifications

Input Power	AT mode (12 V) and ATX mode (12 V and 5 Vsb)
Power States	Supports S0, S1, S3, S4, S5
Power Consumption	19 W (with Core™2 Duo U7500 at 1.06 GHz and 2 GB memory, typical)

Mechanical and Environmental

Operating Temp.	0°C to 60°C
Storage Temp.	20°C to 80°C
Humidity	90% at 60°C
Shock	15G peak-to-peak, 11ms duration, non-operation
Vibration	Non-operating: 1.88 Grms, 5-500 Hz, each axis Operating: 0.5 Grms, 5-500 Hz, each axis
Form Factor	COM Express™ Type 2, Basic form factor, 95 mm x 125 mm
Certifications	CE, FCC

Operating Systems

Standard Support	Windows® XP 32/64-bit Windows® Vista 32/64-bit Windows® Server 2003 Linux® 2.6.x
Extended Support	Embedded XP BSP Linux® 2.6.x BSP AIDI Library for Win32, WinCE and Linux®

Functional Diagram

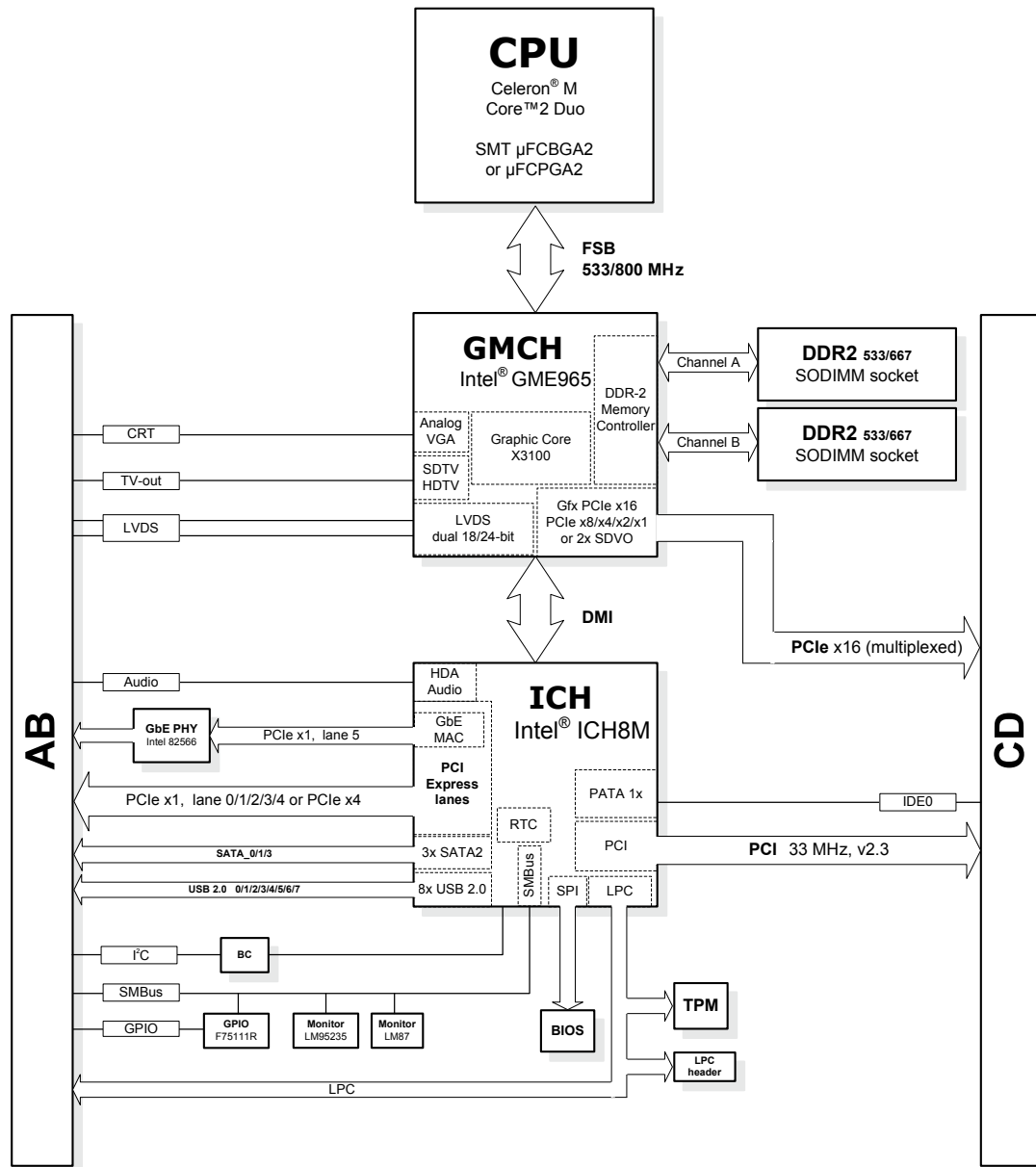

Ordering Information

Modules

Model Number	Description/Configuration
Express-MC800-S	COM Express™ Module with socket for Celeron® M or Core™2 Duo processor (for Intel® Core™2 Duo T7500 processor at 2.2 GHz or Intel® Celeron® M 550 processor at 2.0 GHz)
Express-MC800-L7500	COM Express™ Module with LV Intel® Core™2 Duo L7500 processor at 1.6 GHz
Express-MC800-U7500	COM Express™ Module with ULV Intel® Core™2 Duo U7500 processor at 1.06 GHz

Accessories

Model Number	Description/Configuration
Heat Spreaders	
HTS-MC800-B	Heatspreader for Express-MC800 (BGA CPU) with threaded standoffs
Passive Heatsinks	
THS-MC800-B	Low Profile Heatsink for Express-MC800 (BGA CPU) with threaded standoffs
THSH-MC800-B	High Heatsink for Express-MC800 (BGA CPU) with threaded standoffs
Heatsink with Active Cooling	
THSF-MC800-S	High Performance Heatsink with Fan for Express-MC800 (socket CPU) with threaded standoffs