



Matrix *A Truly Fanless Embedded Computer*

Intelligent Transportation



Facility Management



Environment Monitoring

Machine Automation

Video Surveillance/ Recognition



Compact

Smaller form-factor for easier installation and maintenance



Fanless

Fanless design significantly extends MTBF to 100,000 hours and minimizes the maintenance cost.



Rugged

The Matrix is designed to operate in a -20 to 70°C wide temperature range and withstand up to 100 G shock and 5 G vibration, making it ideal for deployment in harsh environments.

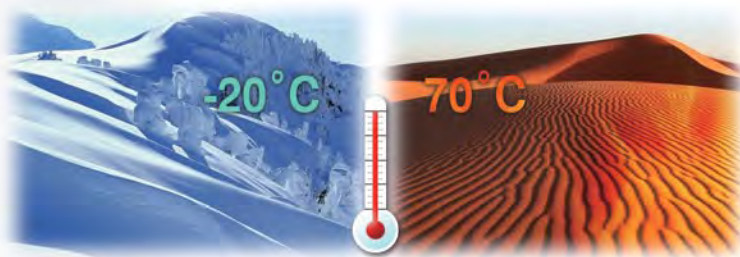

Application-specific

By integrating ADLINK DAQ, DIO, motion and vision technologies, the Matrix can provide specific I/O functions on-board for your applications.



Note: Extending the operating temperature to -20°C to +70°C is optional and requires use of an industrial solid-state drive storage device.

Sophisticated Design of the Matrix

■ Comprehensive Consideration for Heat Dissipation

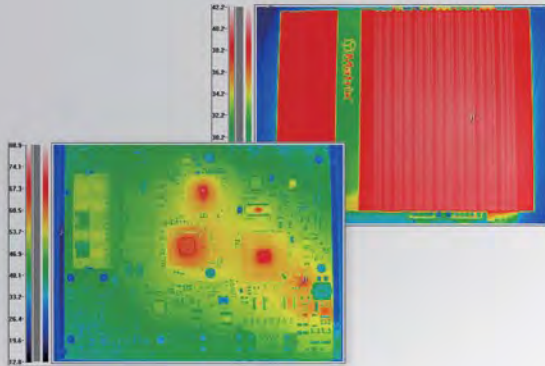

Mechanical and electrical engineers worked from the early design stages of the Matrix to ensure the best performance of conductive heat dissipation. All components, such as the CPU, chipset, memory, clock generator, MOSFET, and power choke, etc. generate heat and are thus placed on the top of the PCB and kept at a minimal pitch from the aluminum case. Thus we can provide the shortest path of heat conduction and lowest thermal resistance to guarantee the thermal stability of the Matrix at a 70°C ambient temperature.

■ Cable-less and User-friendly Mechanical Structure



The Matrix features an excellent cable-less design. All components and connectors are directly mounted on the PCB via SMT and DIP processes instead of cable connections. The result is an extremely strong and durable mechanical structure suitable for the harshest of environments with 5 Grms vibration and up to 100 G shock and vibration. The Matrix MXC series—being an expandable embedded computer—also provides a very user-friendly design for system installation. You can open the chassis and install your PCI/PCIe card simply by loosening screw. And, only four screws are used to install or replace the hard disk drive. The mechanical design provides the best reliability, durability and easiest access for installation and maintenance.

■ Wide Range and Reliable DC Power Input



We know you may need to deploy the Matrix anywhere. So, we designed the Matrix with wide range DC input to allow it to be powered everywhere. Regardless if there is 12 or 24 volts available at the site, or you have a 19 V laptop adapter handy, you can simply feed the electricity into the MXE-1000 series (6-36 Vdc), MXE-3000 series (9-32 Vdc) or MXC series (9-32 Vdc) and it will run. The Matrix is also ideal for use with solar power because of the great tolerance for the variation of solar panel output. The power circuitry of the Matrix was carefully designed with high-quality components (regulators, capacitors, and inductors) to supply reliable power under almost any circumstances.

1

Software & Utilities

2

DAQ

3

PXI

4

Modular Instruments

5

GPIB & Bus Expansion

6

Motion Control

7

Real-time Distributed I/O

8

PAC

9

Remote I/O

10

Communications

11

Vision

12





Fanless Embedded Computers





13

cPCI & Industrial Computers

Selection Guide

Matrix MXC Series-Expandable Embedded Computers

	MXC-2000 Series		MXC-4000 Series
			
Model Name	MXC-2002	MXC-2011	MXC-4002D
System	Intel® Atom™ N270 1.6 GHz	Intel® Atom™ N270 1.6 GHz	Intel® Atom™ D510 1.66 GHz
Processor	Intel® 945GSE+ ICH7-M	Intel® 945GSE+ ICH7-M	Intel® ICH8-M
Chipset	1 GB DDR2 533 MHz SODIMM module	1 GB DDR2 533 MHz SODIMM module	1 GB DDR2 667 MHz SODIMM module
Memory	I/O Interface		
Expansion Slots	2 PCI slots	1 PCI slot and 1 PCIe slot	2 PCI slots
Ethernet	2 GbE ports (Realtek® 8111C)	2 GbE ports (Realtek® 8111C)	2 GbE ports (Intel® 82574L)
Serial Port	2 RS-232/422/485	2 RS-232/422/485	2 RS-232/422/485
COM1 & COM2	2 RS-232	2 RS-232	2 RS-232
COM3 & COM4	4	4	4
USB port	√	√	√
Watchdog Timer	Storage		
SATA HDD	2.5" HDD/SSD installation	2.5" HDD/SSD installation	2.5" HDD/SSD installation
CompactFlash	2 Type II CF sockets	2 Type II CF sockets	1 Type II CF socket
Environment			
Operating Temperature*	Standard: 0°C to 60°C (w/ HDD) Extended option: -20°C to 70°C (w/ industrial SSD)	Standard: 0°C to 60°C (w/ HDD) Extended option: -20°C to 70°C (w/ industrial SSD)	Standard: 0°C to 55°C (w/ HDD) Extended option: -10°C to 60°C (w/ industrial SSD)
General			
Power Supply	9-32 V _{DC}	9-32 V _{DC}	9-32 V _{DC}
Page No.	12-9	12-9	12-7

	MXC-4000 Series	MXC-6000	
			
Model Name	MXC-4011D	MXC-6101D	MXC-6201D
System	Intel® Atom™ D510 1.66 GHz	Intel® Core i7-620LE 2.0 GHz	Intel® Core i7-620LE 2.0 GHz
Processor	Intel® ICH8-M	Intel® QM57	Intel® QM57
Chipset	1 GB DDR2 667 MHz SODIMM module	2 GB DDR3 800/1066 MHz SODIMM module	2 GB DDR3 800/1066 MHz SODIMM module
Memory	I/O Interface		
Expansion Slots	1 PCI slot and 1 PCIe slot	2 PCI slots	1 PCI slot and 1 PCIe x4 slot
Ethernet	2 GbE ports (Intel® 82574L)	2 GbE ports (2 Intel® 82574L)	2 GbE ports (2 Intel® 82574L)
Serial Port	2 RS-232/422/485	2 RS-232/422/485	2 RS-232/422/485
COM1 & COM2	2 RS-232	2 RS-232	2 RS-232
COM3 & COM4	4	4 (external), 1 (internal)	4 (external), 1 (internal)
USB port	√	√	√
Watchdog Timer	Storage		
SATA HDD	2.5" HDD/SSD installation	2.5" HDD/SSD installation	2.5" HDD/SSD installation
CompactFlash	1 Type II CF socket	1 external Type II CF socket, 1 internal Type II CF socket	1 external Type II CF socket, 1 internal Type II CF socket
Environment			
Operating Temperature*	Standard: 0°C to 55°C (w/ HDD) Extended option: -10°C to 60°C (w/ industrial SSD)	Standard: 0°C to 50°C (w/ HDD) Extended option: -10°C to 60°C (w/ industrial SSD)	Standard: 0°C to 50°C (w/ HDD) Extended option: -10°C to 60°C (w/ industrial SSD)
General			
Power Supply	9-32 V _{DC}	9-32 V _{DC}	9-32 V _{DC}
Page No.	12-7	12-5	12-5

*Heat dissipation from inserted PCI/PCIe cards may affect thermal performance.

Selection Guide

Matrix MXE Series-Integrated Embedded Computers

MXE-1000 Series			
Model Name	MXE-1005	MXE-1010	MXE-1020
System			
Processor	Intel® Atom™ N270 1.6 GHz	Intel® Atom™ N270 1.6 GHz	Intel® Atom™ N270 1.6 GHz
Chipset	Intel® 945GSE+ ICH7-M	Intel® 945GSE+ ICH7-M	Intel® 945GSE+ ICH7-M
Memory	1 GB DDR2 533 MHz SODIMM module	1 GB DDR2 533 MHz SODIMM module	1 GB DDR2 533 MHz SODIMM module
I/O Interface			
Ethernet	1 GbE port (Realtek® 8111C)	3 GbE ports (Realtek® 8111C+Intel® 82574) (support teaming function)	1 GbE port (Realtek® 8111C)
Serial Port	COM1 & COM2	2 RS-232/422/485	2 RS-232/422/485
	COM3 & COM4	2 RS-232	2 RS-232
	COM5 - COM12	-	-
USB port	4	4	4
Watchdog Timer	√	√	√
Storage			
SATA HDD	2.5" HDD/SSD installation	2.5" HDD/SSD installation	2.5" HDD/SSD installation
CompactFlash	1 Type I CF socket	1 Type I CF socket	1 Type I CF socket
Environment			
Operating Temperature	Standard: 0°C to 50°C (w/ HDD) Extended option: -20°C to 70°C (w/ industrial SSD)	Standard: 0°C to 50°C (w/ HDD) Extended option: -20°C to 70°C (w/ industrial SSD)	Standard: 0°C to 50°C (w/ HDD) Extended option: -20°C to 70°C (w/ industrial SSD)
General			
Power Supply	6-36 V _{DC}	6-36 V _{DC}	6-36 V _{DC}
Page No.	12-15	12-15	12-15

MXE-1200 Series			MXE-3000 Series
Model Name	MXE-1212/232	MXE-1212/422	MXE-3002
System			
Processor	Intel® Atom™ N270 1.6 GHz	Intel® Atom™ N270 1.6 GHz	Intel® Atom™ D510 1.66 GHz
Chipset	Intel® 945GSE+ ICH7-M	Intel® 945GSE+ ICH7-M	Intel® ICH8-M
Memory	1 GB DDR2 533 MHz SODIMM module	1 GB DDR2 533 MHz SODIMM module	1 GB DDR2 667 MHz SODIMM module
I/O Interface			
Ethernet	1 GbE port (Realtek® 8111C)	1 GbE port (Realtek® 8111C)	3 GbE ports (1 Realtek® 8111C + 2 Intel® 82574L)
Serial Port	COM1 & COM2	2 RS-232/422/485 by DB9 connectors	2 RS-232/422/485
	COM3 & COM4	2 RS-232 by DB9 connectors	2 RS-232
	COM5 - COM12	8 RS-232 by DB62 connector	-
USB port	4	4	6
Watchdog Timer	√	√	√
Storage			
SATA HDD	2.5" HDD/SSD installation	2.5" HDD/SSD installation	2.5" HDD/SSD installation
CompactFlash	1 Type II CF socket	1 Type II CF socket	1 Type II CF socket
Environment			
Operating Temperature	Standard: 0°C to 50°C (w/ HDD) Extended option: -20°C to 70°C (w/ industrial SSD)	Standard: 0°C to 50°C (w/ HDD) Extended option: -20°C to 70°C (w/ industrial SSD)	Standard: 0°C to 50°C (w/ HDD) Extended option: -10°C to 60°C (w/ industrial SSD)
General			
Power Supply	6-36 V _{DC}	6-36 V _{DC}	9-32 V _{DC}
Page No.	12-13	12-13	12-11

1

Software & Utilities

2

DAQ

3

PXI

4

Modular Instruments

5

GPIB & Bus Expansion

6

Motion Control

7

Real-time Distributed I/O

8

PAC

9

Remote I/O

10

Communi-cations

11

Vision

12

Fanless Embedded Computers

13

cPCI & Industrial Computers

Matrix MXC-6000 Series

Powerful Intel® Core i7 Fanless Expandable Embedded Computer with PCI/PCIe Slots



Introduction

The Matrix MXC-6000 series is a powerful fanless, expandable embedded computer using the new Intel® Core i7 2.0 GHz processor to offer greater computing performance for your applications. The MXC-6000 inherits its exceptional fanless and cable-less design from existing Matrix C series.

The MXC-6000 series features an Intel® Core i7 2.0 GHz processor and Intel® QM57 to boost its performance, making it ideal for image and vision measurement and automation applications. Its PCI and PCIe slots provide the possibility to integrate off-the-shelf PCI/PCIe cards and develop a configurable application platform. The built-in 16 isolated DIO channels are provided for general industrial control. Its DVI-D connector output on the front panel allows direct connection to an LCD panel. The MXC-6000 series also provides one eSATA port to enable the capability of either expanding storage capacity or using hot-swappable SATA drives.

Leveraging a reliable fanless and durable cable-less design, the MXC-6000 series exhibits excellent dependability in harsh environments, where severe temperature variation and vibration may exist. The MXC-6000 series provides an optional hot-pluggable fan module to dissipate heat generated within the system when high power consumption PCI/PCIe cards are installed. This inventive mechanical design retains a cable-less structure which dramatically improves thermal stability when PCI/PCIe cards are installed.

The MXC-6000 also provides a USB 2.0 port internally on riser card. This function provides more reliable usage in security applications where license keys or password encryption through an internal USB dongle dramatically improves the security of the Matrix I/O controller.

Combining a reliable design with more computing power and innovative features, the Matrix MXC-6000 series is the optimal choice to base your rugged application system on.

Features

- Intel® Core i7-620LE 2.0 GHz processor + Intel® QM57 chipset
- Configurable, providing PCI and PCIe x4 slots
- Semi-Rugged, -10°C to 60°C fanless operation*
- Built-in 9 Vdc to 32 Vdc wide-range DC power input
- VGA+DVI-D display by DVI-I connector
- Dual 1000/100/10 Mbps Ethernet ports
- Two RS-232 ports and two software-selectable RS-232/422/485 ports
- USB 2.0 port internally on riser card
- Built-in 16-CH isolated DI and 16-CH isolated DO

Applications

- Machine Automation
- Image & Vision Measurement
- Factory Control
- Test Instrumentation
- Safety Surveillance
- Networking Security

■ An Ingenious Design of Easy-to-install, Hot-pluggable Fan Module



1. Open the top cover of MXC-6000



2. Insert the optional fan module by gently slide it into the fan connector



3. Replace the cover

■ An More Reliable Design of Internal USB Port

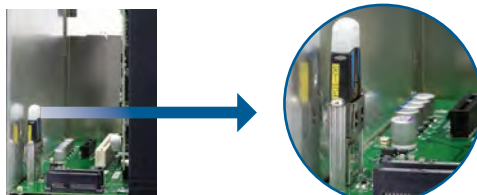

Use USB license keys or password encryption dongle through Matrix internal USB 2.0 port to improve the security applications.

■ MXC-6000 Series Front Panel

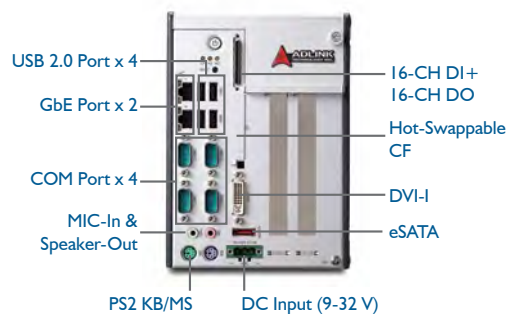

■ Inside the MXC-6000 Series

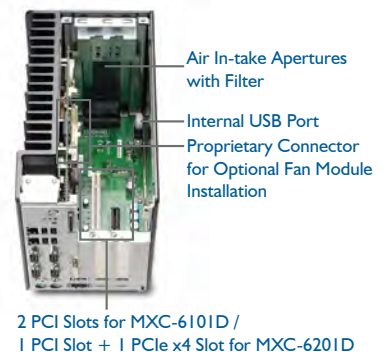

*Extending the operating temperature to -10°C to +60°C is optional and requires use of an industrial solid-state drive storage device.
Heat dissipation from inserted PCI/PCIe cards may affect thermal performance

Specifications

Model Name	MXC-6101D	MXC-6201D
System Core		
■ Processor	Intel® Core i7-620LE 2.0 GHz CPU	
■ Chipset	Intel® QM57	
■ Video	VGA+DVI-D display by DVI-I connector <ul style="list-style-type: none"> Analog CRT, supports QXGA (2048 x 1536) resolution DVI-I 1.0 (DVI-D + VGA) (with external cable for connecting DVI-I connector to DVI-D and VGA device) Optional 48-bit LVDS (by Internal box header) 	
■ Memory	2 GB DDR3 800/1066 MHz SODIMM module (Max. capacity 4 GB)	
I/O Interface		
■ Expansion Slots	2 PCI slots	1 PCI slot and 1 PCIe x4 slot
■ Ethernet	2 GbE ports (2 Intel® 82574L)	
■ Serial Port	2 software-programmable RS-232/422/485 (COM1 & COM2) 2 RS-232 (COM3 & COM4)	
■ USB	4 USB 2.0 ports (external), 1 USB 2.0 port (internal)	
■ Audio	1 mic-in and 1 speaker-out	
■ KB/MS	1 PS/2 keyboard and 1 PS/2 mouse	
■ DIO	16-CH isolated DI + 16-CH isolated DO	
Power Supply		
■ DC Input	AT/ATX, built-in 9-32 Vdc wide-range DC power input 3P pluggable connector with latch (GND, V-, V+)	
■ AC Input	Optional 100 W external AC-DC adapter for AC input	
Storage Device		
■ SATA HDD	On-board SATA port for 2.5" HDD/SSD installation	
■ CompactFlash	1 external type II CompactFlash socket 1 internal type II CompactFlash socket	
■ eSATA	1 eSATA interface connector for external storage expansion	
Mechanical		
■ Optional Fan Module	Optional hot-pluggable fan module for dissipating heat generated by PCI/PCIe card	
■ Dimensions	130 mm (W) x 225 mm (D) x 183 mm (H) (5.1" x 8.9" x 7.2")	
■ Weight	3.5 kg (7.72 lbs)	
■ Mounting	Wall-mount kit	
Environmental		
■ Operating Temperature*	Standard: 0°C to 50°C (w/HDD) Extended option: -10°C to 60°C (w/industrial SSD)	
■ Storage Temperature	-40°C to 85°C (excl. HDD/SDD/CF)	
■ Humidity	~95% @ 40°C (non-condensing)	
■ Vibration	Operating, 5 Grms, 5-500 Hz, 3 axes (w/ CF or SSD) Operating, 0.5 Grms, 5-500 Hz, 3 axes (w/ HDD)	
■ Shock	Operating, 50 Grms, Half sine 11 ms duration (w/ CF or SSD)	
■ EMC	CE and FCC	

*Without PCI/PCIe card and 1 HDD storage installation.

Ordering Information

Model Name	Description	PCI	x4 PCIe	GbE	eSATA	COM	USB	Memory	DIO
MXC-6101D	Intel® Core i7-620LE 2.0 GHz fanless expandable embedded computer	2	0	2	1	4	5	2 GB DDR3	16 DI+16 DO
MXC-6201D	Intel® Core i7-620LE 2.0 GHz fanless expandable embedded computer	1	1	2	1	4	5	2 GB DDR3	16 DI+16 DO

Optional Accessories

MXC-6000 Optional Fan Module	Hot-pluggable fan module for the MXC-6000 series
4 GB DDR3 upgrade	Upgrade to 4 GB DDR3 memory
160 GB HDD option	Factory-installation of 160 GB SATA hard disk drive (0 to 60°C)
32 GB SSD option	Factory-installation of 32 GB SATA solid-state drive (0 to 70°C)
8 GB industrial SSD option	Factory-installation of 8 GB industrial-grade SATA solid-state drive (-40 to 85°C)
100 W AC adapter	100 W industrial-grade AC adapter (-20 to 70°C)
Extended Temperature Option*	Extend the operating temperature of the MXC-6000 series to -10°C to 60°C

*This option guarantees cold boot of the system at -10°C and operation with 100% loading at 60°C. The industrial solid-state drive storage option is required.

Matrix MXC-4000 Series

Intel® Atom™ Dual-Core Fanless Expandable Embedded Computer with PCI/PCIe Slots



Introduction

The Matrix MXC-4000 series is a fanless, expandable embedded computer based on the Intel® Atom™ D510 dual-core processor to offer greater computing power for your applications. The MXC-4000 inherits its exceptional fanless and cable-less design from existing Matrix C series, with the addition of innovative features, such as an eSATA interface, an LVDS output, and a hot-pluggable fan option.

The MXC-4000 series features an Intel® Atom™ D510 dual-core 1.66 GHz processor to boost its performance to almost twice that of the Atom™ N270 platform, while maintaining the same overall power consumption. Its PCI and PCIe slots give you the possibility to integrate off-the-shelf PCI/PCIe cards and develop a configurable application platform. Built-in isolated DIO channels are provided for general industrial control. Its LVDS output on the front panel allows you to directly connect to a LCD panel. The MXC-4000 series also provides two eSATA ports to enable the capability of either expanding storage capacity or using hot-swappable SATA drives.

Leveraging a reliable fanless and durable cable-less design, the MXC-4000 series exhibits excellent dependability in harsh environments, where severe temperature variation and vibration may exist. The MXC-4000 series provides an optional hot-pluggable fan module to dissipate heat generated within the system when high power consumption PCI/PCIe cards are installed. This ingenious mechanical design retains a cable-less structure which dramatically improves thermal stability when PCI/PCIe cards installed.

Combining a reliable design with more computing power and innovative features, the Matrix MXC-4000 series is the optimal choice to base your rugged application system on.

Features

- Intel® Atom™ D510 1.66 GHz processor + ICH8-M chipset
- Configurable, providing PCI and PCIe slots
- Rugged, -10°C to 60°C fanless operation*
- Built-in 9 Vdc to 32 Vdc wide-range DC power input
- VGA + LVDS independent dual display
- Dual 1000/100/10 Mbps Ethernet ports
- Two RS-232 ports and two software-selectable RS-232/422/485 ports
- Two eSATA ports for storage expansion
- Built-in 12-CH isolated DI and 12-CH isolated DO

Applications

- Machine Automation
- Intelligent Transportation
- Factory Control
- Test Instrumentation
- Safety Surveillance
- Building Automation

■ MXC-4000 Series Front Panel

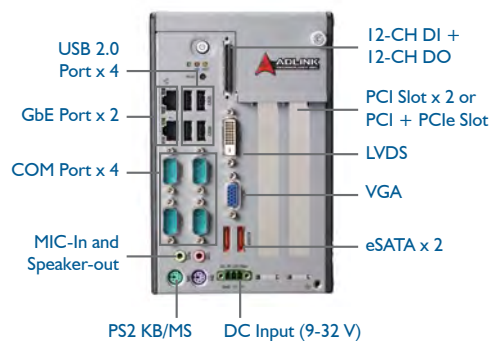

■ Inside the MXC-4000 Series

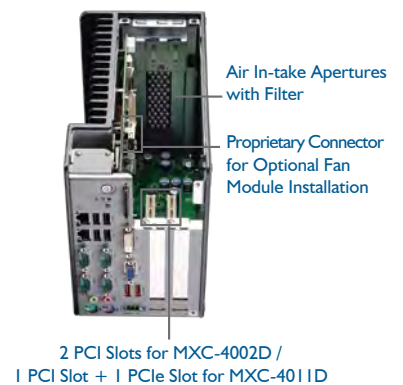

■ An Ingenious Design of Easy-to-install, Hot-pluggable Fan Module

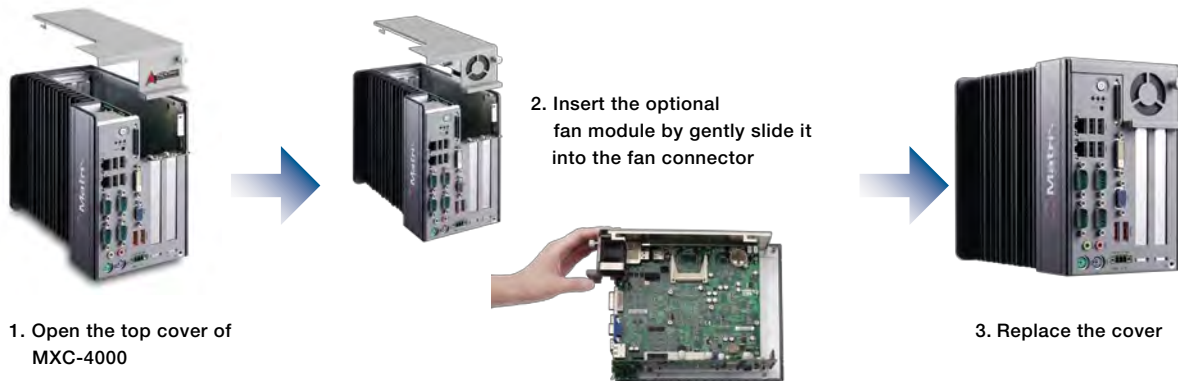

*Extending the operating temperature to -10°C to +60°C is optional and requires use of an industrial solid-state drive storage device. Heat dissipation from inserted PCI/PCIe cards may affect thermal performance.

Specifications

Model Name	MXC-4002D	MXC-4011D
System Core		
■ Processor	Intel® Atom™ D510 1.66 GHz Dual-Core CPU	
■ Chipset	Intel® I/O Control Hub 8 Mobile (ICH8-M)	
■ Video	Analog CRT, supports QXGA (2048 X 1536) resolution 18-bit LVDS output by DVI-D connector for LCD panel	
■ Memory	1 GB DD2 667 MHz SODIMM module	
I/O Interface		
■ Expansion Slots	2 PCI slots	1 PCI slot and 1 PCIe x1 slot
■ Ethernet	2 GbE ports (Intel® 82574L)	
■ DIO	12-CH isolated DI + 12-CH isolated DO	
■ Serial Port	2 software-programmable RS-232/422/485 (COM1 & COM2) 2 RS-232 (COM3 & COM4)	
■ USB	4 USB 2.0 ports	
■ Audio	1 mic-in and 1 speaker-out	
■ KB/MS	1 PS/2 keyboard and 1 PS/2 mouse	
Power Supply		
■ DC Input	Built-in 9-32 Vdc wide-range DC input with over-voltage protection 3P pluggable connector with latch (GND, V-, V+)	
■ AC Input	Optional 60 W external AC-DC adapter for AC input	
Storage Device		
■ SATA HDD	On-board SATA port for 2.5" HDD/SSD installation	
■ eSATA	2 eSATA interface connectors for external storage expansion	
■ CompactFlash	1 type II CF socket, supporting PIO and DMA modes for HDD replacement	
Mechanical		
■ Optional Fan Module	Optional, hot-pluggable fan module for dissipating heat generated by PCI/PCIe card	
■ Dimensions	118 mm (W) x 219 mm (D) x 183 mm (H) (4.6" x 8.6" x 7.2")	
■ Weight	2.8 kg (6.17 lbs)	
■ Mounting	Wall-mount kit	
Environmental		
■ Operating Temperature*	Standard: 0°C to 55°C (w/HDD) Extended option: -10°C to 60°C (w/industrial SSD)	
■ Storage Temperature	-40°C to 85°C (excl. HDD/SDD/CF)	
■ Humidity	~95% @ 40°C (non-condensing)	
■ Vibration	Operating, 5 Grms, 5-500 Hz, 3 axes (w/ CF or SSD) Operating, 0.5 Grms, 5-500 Hz, 3 axes (w/ HDD)	
■ Shock	Operating, 50 Grms, half sine 11 ms duration (w/ CF or SSD)	
■ EMC	CE and FCC	

*Without PCI/PCIe card installation

Ordering Information

Model Name	Description	PCI	x1 PCIe	GbE	eSATA	COM	USB	Memory	DIO
MXC-4002D	Intel® Atom™ D510 fanless expandable embedded computer	2	0	2	2	4	4	1 GB DDR2	12 DI+ 12 DO
MXC-4011D	Intel® Atom™ D510 fanless expandable embedded computer	1	1	2	2	4	4	1 GB DDR2	12 DI+ 12 DO

Optional Accessories

MXC-4000 Optional Fan Module	Hot-pluggable fan module for the MXC-4000 series
2 GB DDR2 Upgrade	Upgrade to 2 GB DDR2 memory
160 GB HDD Option	Factory-installation of 160 GB SATA hard disk drive (0 to 60°C)
32 GB SSD Option	Factory-installation of 32 GB SATA solid-state drive (0 to 70°C)
8 GB Industrial SSD Option	Factory-installation of 8 GB industrial-grade SATA solid-state drive (-40 to 85°C)
80 W AC Adapter	80 W industrial-grade AC adapter (-20 to 70°C)
Extended Temperature Option*	Extend the operating temperature of the MXC-4000 series to -10°C to 60°C

*This option guarantees cold boot of the system at -10°C and operation with 100% loading at 60°C. The industrial solid-state drive storage option is required.

Matrix MXC-2000 Series

Intel® Atom™ Fanless Expandable Embedded Computer with PCI/PCIe Slots



Introduction

ADLINK's MXC-2000 series is an exceptionally fanless expandable embedded computer with configurable PCI and PCIe slots. It is designed to provide a reliable platform for a wide variety of applications by accepting standard PCI and PCIe cards. The Matrix MXC-2000 series can operate in a -20 to 70°C temperature range and withstands 5 Grms vibration. Its fanless and cable-less structure provides additional durability for long-term usage.

The Matrix MXC-2000 series features the Intel® Atom™ N270 1.6 GHz processor to deliver adequate performance at low power. Its PCI and PCIe slots enable the possibility of integrating off-the-shelf PCI/PCIe cards for a configurable application platform. Generic I/O interfaces, such as Gigabit Ethernet, COM, and USB are provided for connecting devices, while VGA+S-Video dual graphic outputs to allow connections to larger displays such as an LCD TV. The Matrix MXC-2000 series also integrates ADLINK in-house DIO design to deliver optional isolated DIO channels for industrial control usage.

ADLINK's Matrix MXC-2000 series is the perfect combination of configurability, reliability, durability, and compactness. With the MXC-2000 series, creating your rugged application system has never been easier.

Features

- Intel® Atom™ N270 1.6 GHz processor + 945GSE chipset
- Configurable, providing both PCI and PCIe x1 slot options
- Rugged, -20°C to 70°C fanless operation*
- Built-in 9 Vdc to 32 Vdc wide-range DC power input
- Dual 1000/100/10 Mbps Ethernet ports
- Two RS-232 ports and two RS-232/422/485 ports
- Two CF sockets for HDD replacement and hot-swappable data storage
- VGA + S-Video independent dual display outputs
- Optional on-board 16-CH isolated DI and 16-CH isolated DO

Applications

- Industrial Automation
- Factory Control
- Test Instrumentation
- Security Surveillance
- Data Acquisition System
- Building Automation



Inside MXC-2000 Series

**Cable-free!
Trouble-free!**



Easy Installation for HDD and PCI/PCIe Cards

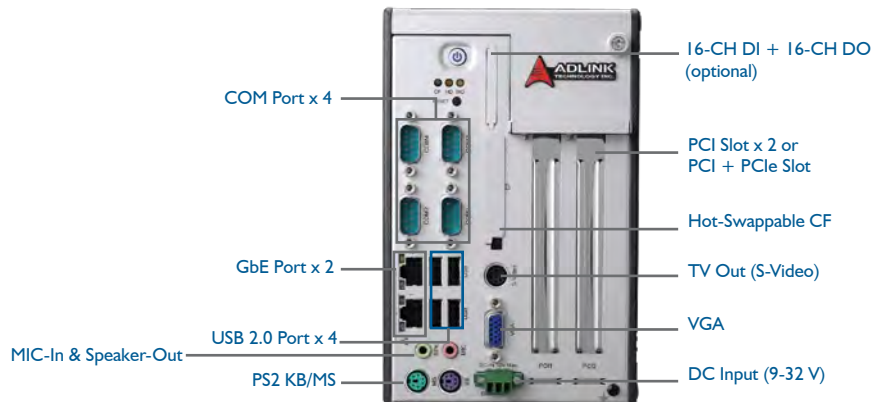

MXC-2000 Series Front Panel

*Extending the operating temperature to -20°C to +70°C is optional and requires use of an industrial solid-state drive storage device. Heat dissipation from inserted PCI/PCIe cards may affect thermal performance.

Specifications

Model Name	MXC-2002	MXC-2011
System Core		
■ Processor	Intel® Atom™ N270 1.6 GHz CPU	
■ Chipset	Intel® 945GSE Graphic Memory Control Hub Intel® I/O Controller Hub 7 Mobile (ICH7-M)	
■ Video	Analog CRT, supports QXGA (2048 x 1536) resolution TV-out, supports s-video and composite outputs	
■ Memory	1 GB DDR2 533 MHz SODIMM module	
I/O Interface		
■ Expansion Slots	2 PCI slots	1 PCI slot and 1 PCIe x1 slot
■ Ethernet	2 GbE ports (Realtek® 8111C)	
■ Serial Port	2 RS-232/422/485 (jumper selectable, COM1 & COM2) 2 RS-232 (COM3 & COM4)	
■ USB	4 USB 2.0 ports	
■ Audio	1 mic-in and 1 speaker-out	
■ KB/MS	1 PS/2 keyboard and 1 PS/2 mouse	
■ DIO	Optional 16-CH isolated DI + 16-CH isolated DO	
Power Supply		
■ DC Input	Built-in 9-32 Vdc input with over-voltage protection 3P pluggable connector with latch (GND, V-, V+)	
■ AC Input	Optional 60 W external AC-DC adapter for AC input	
Storage Device		
■ SATA HDD	On-board SATA port for 2.5" HDD/SSD installation	
■ CompactFlash	2 type II CF Sockets, supporting PIO and DMA modes CF1 (internal) for HDD replacement CF2 (external) supports hot-swapping	
Mechanical		
■ Dimensions	118 mm (W) x 219 mm (D) x 183 mm (H) (4.6" x 8.6" x 7.2")	
■ Weight	2.8 kg (6.17 lbs)	
■ Mounting	Wall-mount kit	
Environmental		
■ Operating Temperature*	Standard: 0°C to 60°C (w/HDD) Extended option: -20°C to 70°C (w/industrial SSD)	
■ Storage Temperature	-40°C to 85°C (excluding HDD/SSD/CF)	
■ Humidity	~95% @ 40°C (non-condensing)	
■ Vibration	Operating, 5 Grms, 5-500 Hz, 3 axes (w/CF or SSD) Operating, 0.7 Grms, 5-500 Hz, 3 axes (w/HDD)	
■ Shock	Operating, 50 Grms, half-sine 11 ms duration (w/CF or SSD)	
■ EMC	CE and FCC	

*Without PCI/PCIe card installation

Ordering Information

Model Name	Description	PCI	x1 PCIe	GbE	COM	USB	Memory	DIO
MXC-2002	Intel® Atom™ N270 fanless expandable embedded computer	2	0	2	4	4	1 GB DDR2	
MXC-2002D	Intel® Atom™ N270 fanless expandable embedded computer	2	0	2	4	4	1 GB DDR2	16 DI+ 16 DO
MXC-2011	Intel® Atom™ N270 fanless expandable embedded computer	1	1	2	4	4	1 GB DDR2	
MXC-2011D	Intel® Atom™ N270 fanless expandable embedded computer	1	1	2	4	4	1 GB DDR2	16 DI+ 16 DO

Optional Accessories

2 GB DDR2 Upgrade	Upgrade to 2 GB DDR2 memory
160 GB HDD Option	Factory-installation of 160 GB SATA hard disk drive (0 to 60°C)
32 GB SSD Option	Factory-installation of 32 GB SATA solid-state drive (0 to 70°C)
8 GB Industrial SSD Option	Factory-installation of 8 GB industrial-grade SATA solid-state drive (-40 to 85°C)
60 W AC Adapter	60 W industrial-grade AC adapter (-20 to 70°C)
Extended Temperature Option*	Extend the operating temperature of the MXC-2000 series to -20°C to 70°C

*This option guarantees cold boot of the system at -20°C and operation with 100% loading at 70°C. The industrial solid-state drive storage option is required.

Matrix MXE-3000 Series

Intel® Atom™ D510 Fanless Embedded Computer with Integrated I/O



Introduction

The Matrix MXE-3000 series is the latest addition to the ADLINK's Matrix E series. It is based on the Intel® Atom™ D510 dual-core processor to offer greater computing power for your applications. The MXE-3000 series features an Intel® Atom™ D510 dual-core 1.66 GHz processor to boost its performance to almost twice that of the Atom™ N270 platform, while maintaining the same power consumption. This distinctive feature delivers to the ability to access multiple devices using a compact and rugged controller without the need for additional serial communication cards.

Leveraging the design of the Matrix MXE-1000 series, the MXE-3000 series retains all the remarkable features of the Matrix E series, including rugged -10°C to 60°C* fanless operation, 5 Grms vibration resistance, and 9-32 Vdc wide range power input. The design of serial ports is also flexible to meet the needs of a wide variety of applications. Two COM ports can be configured to RS-232, RS-422, or RS-485 via a BIOS setting. The MXE-3000 series is also equipped with a mini-PCIe socket, USIM socket, six USB 2.0 ports, and its fanless and cable-less structure gives you extensive durability for long-term usage.

Combining rugged design and integrated I/O functions, the ADLINK MXE-3000 series provides the best choice for your versatile applications.

Features

- Intel® Atom™ D510 1.66 GHz processor + Intel® ICH8-M chipset
- Rugged, -10°C to 60°C fanless operation*
- Built-in 9 Vdc to 32 Vdc wide-range DC power input
- Two software-programmable RS-232/422/485 ports, and two RS-232 ports
- Up to three 1000/100/10 Mbps Ethernet ports
- Up to six USB 2.0 ports
- One internal PCIe Mini Card socket and USIM socket with antenna cable pre-installed
- One external CF socket

Applications

- Toll Gate Controllers
- Smart Grid Applications
- Intelligent Transportation Systems
- Facility Management
- Medication Management
- Pharmacy Automation
- Environmental Monitoring
- Building Automation

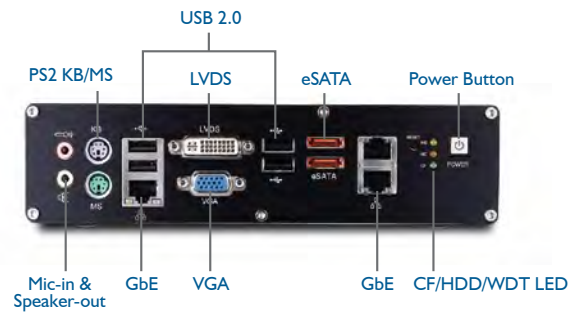

MXE-3000 Front Panel

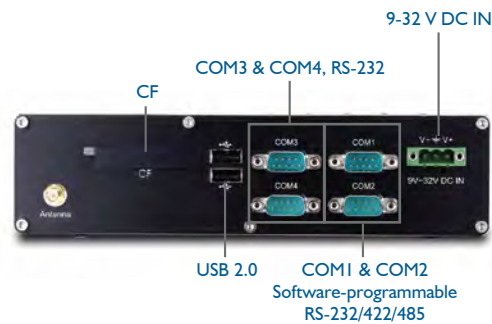

MXE-3000 Back Panel



MXE-3000 with Antenna

*Extending the operating temperature to -10°C to +60°C is optional and requires use of an industrial solid-state drive storage device.

1
Software & Utilities

2
DAQ

3
PXI

4
Modular Instruments

5
GPiB & Bus Expansion

6
Motion Control

7
Real-time Distributed I/O

8
PAC

9
Remote I/O

10
Communications

11
Vision

12
Fanless Embedded Computers

13
cPCI & Industrial Computers

Specifications

Model Name	MXE-3002
System Core	
■ Processor	Intel® Atom™ D510 1.66 GHz CPU
■ Chipset	Intel® I/O Controller Hub 8 Mobile (ICH8-M)
■ Video	VGA+LVDS output by VGA+DVI-I stacked connector • Analog CRT, supports QXGA (2048 x 1536) resolution • 18-bit LVDS output by DVI-D connector
■ Memory	1 GB DDR2 667 MHz SODIMM module
I/O Interface	
■ Ethernet	3 GbE ports (1 Realtek® 8111C + 2 Intel® 82574L)
■ Serial Port	2 software-programmable RS-232/422/485 (COM1 & COM2) 2 RS-232 (COM3 & COM4)
■ USB	6 USB 2.0 ports
■ Audio	1 mic-in and 1 speaker-out
■ KB/MS	1 PS/2 keyboard and 1 PS/2 mouse
■ Mini PCIe	1 internal PCIe mini card socket
■ USIM	1 USIM socket for 3G communication (used for a 3G-mini module)
■ Antenna	1 SMA Antenna connector with SMA-to-IPEX cable pre-installed
Power Supply	
■ DC Input	Built-in 9-32 Vdc wide-range DC input 3P pluggable connector with latch (GND, V-, V+)
■ AC Input	Optional 60 W external AC-DC adapter for AC input
Storage Device	
■ SATA HDD	On-board SATA port for 2.5" HDD/SSD installation
■ CompactFlash	1 type II CF socket, supporting PIO and DMA modes
■ eSATA	2 eSATA interface connectors on front panel for storage expansion
Mechanical	
■ Dimensions	210 mm (W) x 170 mm (D) x 53 mm (H) (8.3" x 6.7" x 2.1")
■ Weight	1.8 kg (3.97 lbs)
■ Mounting	Wall-mount kit
Environmental	
■ Operating Temperature	Standard: 0°C to 50°C (w/HDD) Extended option: -10°C to 60°C (w/ industrial SSD)
■ Storage Temperature	-40°C to 85°C (excl. HDD/SDD/CF)
■ Humidity	~95% @ 40°C (non-condensing)
■ Vibration	Operating, 5 Grms, 5-500 Hz, 3 axes (w/ CF or SSD) Operating, 0.5 Grms, 5-500 Hz, 3 axes (w/ HDD)
■ EMD	Contact +/-4 KV and Air +/-8 KV
■ Shock	Operating, 100 Grms, half sine 11 ms duration (w/ CF or SSD)
■ EMC	CE and FCC, and Class A

Ordering Information

Model Name	Description	COM Ports	GbE	USB	Memory
MXE-3002	Intel® Atom™ D510 1.66 G fanless embedded computer	2 RS-232/422/485 2 RS-232	3	6	1 GB DDR2

Optional Accessories

2 GB DDR2 upgrade	Upgrade to 2 GB DDR2 memory
160 GB HDD option	Factory-installation of 160 GB SATA hard disk drive (0 to 60°C)
32 GB SSD option	Factory-installation of 32 GB SATA solid-state drive (0 to 70°C)
8 GB industrial SSD option	Factory-installation of 8 GB industrial-grade SATA solid-state drive (-40 to 85°C)
80 W AC adapter	80 W industrial-grade AC adapter (-20 to 70°C)
Extended Temperature Option*	Extend operating temperature of MXE-3000 series to -10°C to 60°C

*This option guarantees cold boot of the system at -10°C and operation with 100% loading at 60°C. The industrial solid-state drive storage option is required.

Matrix MXE-1200 Series

Intel® Atom™ N270 Fanless Embedded Computer with 12 COM Ports



Introduction

The Matrix MXE-1200 series is the latest addition to the ADLINK's Matrix E series. It is based on the Intel® Atom™ N270 1.6 GHz processor and provides 12 serial ports for device communication and control. This distinctive feature delivers to the ability to access multiple devices using a compact and rugged controller without the need for additional serial communication cards.

Leveraging the design of the Matrix MXE-1000 series, the MXE-1200 series retains all the remarkable features of the Matrix E series, including rugged -20 to 70°C fanless operation, 5 Grms vibration resistance, and 6-36 VDC wide range power input. The design of serial ports is also flexible to meet the need of a wide variety of applications. Two of the 12 COM ports can be configured to RS-232, RS-422 or RS-485 via a BIOS setting. The remaining COM ports are either RS-232 (MXE-1212/232), RS-422 (MXE-1212/422) or RS-485 (MXE-1212/485). The MXE-1200 series is also equipped with a mini-PCIe socket, USIM socket, and pre-installed SMA-to-IPEX antenna cable to support expansion of wireless communication capabilities.

Combining reliability, compactness, and a unique feature of 12 COM ports, the MXE-1200 series is the perfect fit for communicating with external devices which will greatly benefit many applications such as toll gate control (RS-232), automatic fare collection systems (RS-232), and smart grid (RS-422/485).

Features

- Intel® Atom™ N270 1.6 GHz processor + 945GSE chipset
- Rugged, -20°C to 70°C fanless operation*
- Provides 12 COM ports
 - Two software-programmable RS-232/422/485 ports
 - 10 RS-232 ports (MXE-1212/232), 10 RS-422 (MXE-1212/422), or 10 RS-485 ports (MXE-1212/485)
- Built-in 6 V_{DC} to 36 V_{DC} wide-range DC power input
- One 1000/100/10 Mbps Ethernet port
- One internal PCIe mini card socket and USIM socket with antenna cable pre-installed
- One external CF socket

Applications

- Toll Gate Controllers
- Smart Grid Applications
- Intelligent Transportation Systems
- Facility Management
- Environmental Monitoring
- Building Automation

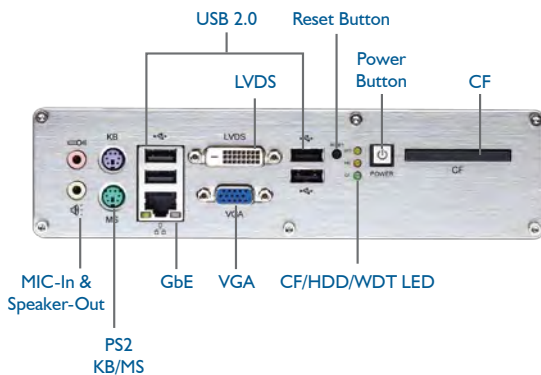

MXE-1200 Series Front Panel

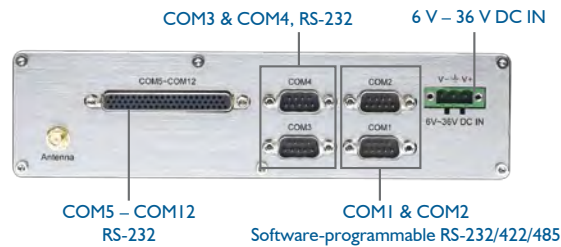

MXE-1212/232 Back Panel

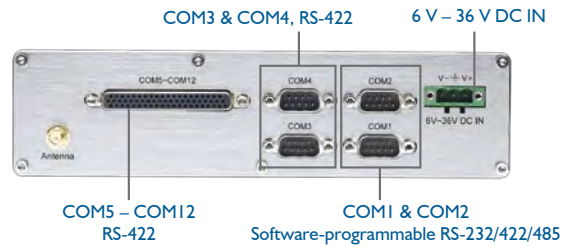

MXE-1212/422 Back Panel

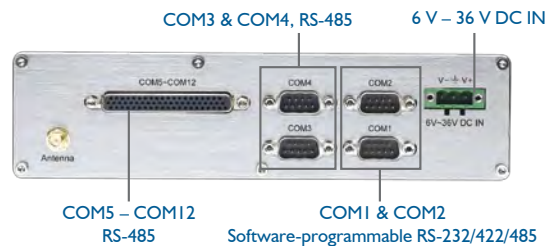

MXE-1212/485 Back Panel



MXE-1200 Series with Antenna

*Extending the operating temperature to -20°C to +70°C is optional and requires use of an industrial solid-state drive storage device.

- 1 Software & Utilities
- 2 DAQ
- 3 PXI
- 4 Modular Instruments
- 5 GPIB & Bus Expansion
- 6 Motion Control
- 7 Real-time Distributed I/O
- 8 PAC
- 9 Remote I/O
- 10 Communications
- 11 Vision
- 12 Fanless Embedded Computers
- 13 cPCI & Industrial Computers

Specifications

Model Name	MXE-1212/232	MXE-1212/422	MXE-1212/485
System Core			
Processor	Intel® Atom™ N270 1.6 GHz CPU		
Chipset	Intel® 945GSE Graphic Memory Control Hub Intel® I/O Controller Hub 7 Mobile (ICH7-M)		
Video	Analog CRT, supports QXGA (2048 X 1536) resolution 18-bit LVDS output by DVI-D connector for LCD panel		
Memory	1 GB DDR2 533 MHz SODIMM module		
I/O Interface			
Serial Port	COM1 & COM2	2 software-programmable RS-232/422/485 by DB9 connectors	
	COM3 & COM4	2 RS-232 by DB9 connectors	2 RS-422 by DB9 connectors
	COM5 - COM12	8 RS-232 by DB62 connector	8 RS-422 by DB62 connector
Ethernet	1 GbE port (Realtek® 8111C)		
USB	4 USB 2.0 ports		
Mini-PCIe	1 internal PCIe mini card socket		
USIM	1 USIM socket for 3G communication (used for a 3G mini-PCIe module)		
Antenna	1 SMA Antenna connector with SMA-to-IPEX cable pre-installed		
Audio	1 mic-in and 1 speaker-out		
KB/MS	1 PS/2 keyboard and 1 PS/2 mouse		
DIO	Optional DIO via proprietary mezzanine board		
Power Supply			
DC Input	Built-in 6-36 Vdc wide-range DC input 3P pluggable connector with latch (V-, GND, V+)		
AC Input	Optional 40 W external AC-DC adapter for AC input		
Storage Device			
SATA HDD	On-board SATA port for 2.5" HDD/SSD installation		
CompactFlash	1 type II CF socket, supporting PIO and DMA modes for HDD replacement		
Mechanical			
Dimensions	210 mm (W) x 170 mm (D) x 54 mm (H) (8.3" x 6.7" x 2.1")		
Weight	1.9 kg (4.19 lbs)		
Mounting	VESA 100 mounting kit for wall-mount		
Environmental			
Operating Temperature	Standard: 0°C to 50°C (w/HDD) Extended option: -20°C to 70°C (w/industrial SSD)		
Storage Temperature	-40°C to 85°C (excl. HDD/SDD/CF)		
Humidity	~95% @ 40°C (non-condensing)		
Vibration	Operating, 5 Grms, 5-500 Hz, 3 axes (w/ CF or SSD) Operating, 0.5 Grms, 5-500 Hz, 3 axes (w/ HDD)		
Shock	Operating, 100 Grms, half sine 11 ms duration (w/ CF or SSD)		
EMC	CE and FCC		

Ordering Information

Model Name	Description	COM Ports	GbE	USB	Memory
MXE-1212/232	Intel® Atom™ N270 fanless embedded computer	2 RS-232/422/485 10 RS-232	1	4	1 GB DDR2
MXE-1212/422	Intel® Atom™ N270 fanless embedded computer	2 RS-232/422/485 10 RS-422	1	4	1 GB DDR2
MXE-1212/485	Intel® Atom™ N270 fanless embedded computer	2 RS-232/422/485 10 RS-485	1	4	1 GB DDR2

Optional Accessories

2 GB DDR2 Upgrade	Upgrade to 2 GB DDR2 memory
160 GB HDD Option	Factory-installation of 160 GB SATA hard disk drive (0 to 60°C)
32 GB SSD Option	Factory-installation of 32 GB SATA solid-state drive (0 to 70°C)
8 GB Industrial SSD Option	Factory-installation of 8 GB industrial-grade SATA solid-state drive (-40 to 85°C)
40 W AC Adapter	40W industrial-grade AC adapter (-20 to 70°C)
Extended Temperature Option*	Extend operating temperature of MXE-1200 series to -20°C to 70°C

*This option guarantees cold boot of the system at -20°C and operation with 100% loading at 70°C. The industrial solid-state drive storage option is required.

Matrix MXE-1000 Series

Intel® Atom™ Fanless Embedded Computer with Integrated I/O



Introduction

ADLINK's MXE-1000 series is an exceptionally rugged embedded computer for operating in harsh environments. Its -20 to 70°C* temperature range allows it to operate outdoors in both hot summer days and cold winter nights. The Matrix can also be deployed in factory planes or on vehicles as it can withstand 5 Grms vibration. And, its fanless and cable-less structure ensures extensive durability for long-term usage.

The Matrix MXE-1000 series features the Intel® Atom™ N270 1.6 GHz processor to deliver adequate performance at low-power. The MXE-1000 also integrates versatile generic and special-purpose I/O features to support a wide variety of applications. The on-board Gigabit Ethernet and 1394b ports are designed for connecting cameras for surveillance and image recognition applications, while its COM ports fit requirements in most machine automation and facility management applications.

Combining rugged design and integrated I/O functions, the ADLINK MXE-1000 series offers the most versatile choice for your applications.

Features

- Intel® Atom™ N270 1.6 GHz processor + 945GSE chipset
- Rugged, -20°C to 70°C fanless operation*
- Built-in 6 Vdc to 36 Vdc wide-range DC power input
- Up to three 1000/100/10 Mbps Ethernet ports
- Two 1394b FireWire ports (MXE-1020 only)
- Two RS-232 ports and two RS-232/422/485 ports
- One internal PCIe Mini Card socket with an USIM socket
- One external CF socket

Applications

- Intelligent Transportation
- Facility Management
- Environment Monitoring
- Machine Automation
- Video Surveillance/Recognition
- Building Automation



Inside MXE-1000 Series

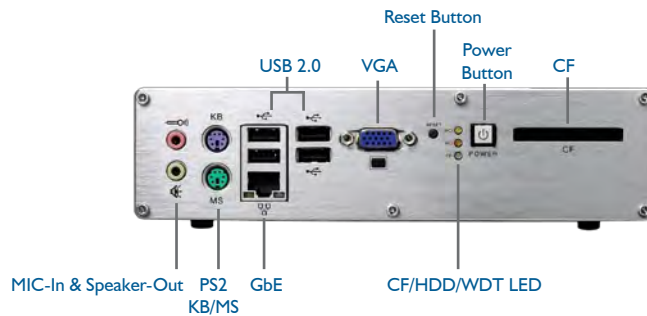

MXE-1000 Series Front Panel

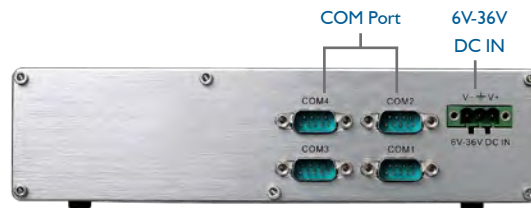

MXE-1005 Back Panel

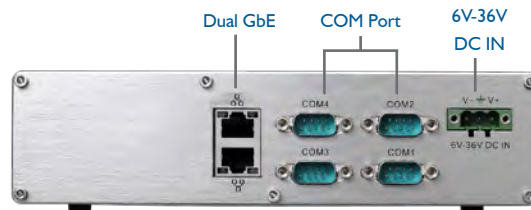

MXE-1010 Back Panel

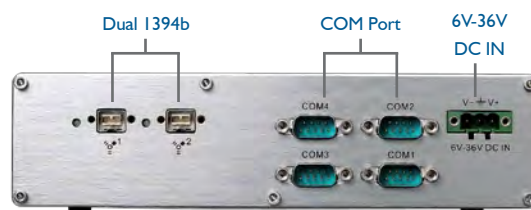

MXE-1020 Back Panel

*Extending the operating temperature to -20°C to +70°C is optional and requires use of an industrial solid-state drive storage device.

- 1 Software & Utilities
- 2 DAQ
- 3 PXI
- 4 Modular Instruments
- 5 GPIB & Bus Expansion
- 6 Motion Control
- 7 Real-time Distributed I/O
- 8 PAC
- 9 Remote I/O
- 10 Communications
- 11 Vision
- 12 Fanless Embedded Computers
- 13 cPCI & Industrial Computers

Specifications

Model Name	MXE-1005	MXE-1010	MXE-1020
System Core			
■ Processor	Intel® Atom™ N270 1.6 GHz CPU		
■ Chipset	Intel® 945GSE Graphic Memory Control Hub Intel® I/O Controller Hub 7 Mobile (ICH7-M)		
■ Video	Analog CRT, supports QXGA (2048 x 1536) resolution		
■ Memory	1 GB DDR2 533 MHz SODIMM module		
I/O Interface			
■ Ethernet	1 GbE port (Realtek® 8111C)	3 GbE ports (Realtek® 8111C+Intel® 82574) (support teaming function)	1 GbE port (Realtek® 8111C)
■ 1394b	-	-	2 1394b FireWire 800 ports
■ Serial Port	2 RS-232/422/485 (jumper selectable, COM1 & COM2) 2 RS-232 (COM3 & COM4)		
■ USB	4 USB 2.0 ports		
■ Mini-PCIe	1 internal PCIe mini card socket		
■ USIM	1 USIM socket for 3G communication (used with 3G Mini-PCIe module)		
■ Audio	1 mic-in and 1 speaker-out		
■ KB/MS	1 PS/2 keyboard and 1 PS/2 mouse		
Power Supply			
■ DC Input	Built-in 6-36 Vdc wide-range DC input 3P pluggable connector with latch (V-, GND, V+)		
■ AC Input	Optional 40 W external AC-DC adapter for AC input		
Storage Device			
■ SATA HDD	On-board SATA port for 2.5" HDD/SSD installation		
■ CompactFlash	1 type I CF socket, supporting PIO and DMA modes		
Mechanical			
■ Dimensions	210 mm (W) x 170 mm (D) x 53 mm (H) (8.3" x 6.7" x 2.1")		
■ Weight	1.8 kg (3.97 lbs)		
■ Mounting	VESA 100 wall mounting kit		
Environmental			
■ Operating Temperature	Standard: 0°C to 50°C (w/HDD) Extended option: -20°C to 70°C (w/industrial SSD)		
■ Storage Temperature	-40°C to 85°C (excluding HDD/SSD/CF)		
■ Humidity	~95% @ 40°C (non-condensing)		
■ Vibration	Operating, 5 Grms, 5-500 Hz, 3 axes (w/ CF or SSD) Operating, 0.7 Grms, 5-500 Hz, 3 axes (w/ HDD)		
■ Shock	Operating, 100 Grms, half-sine 11 ms duration (w/ CF or SSD)		
■ EMC	CE and FCC		

Ordering Information

Model Name	CPU	GbE	1394b	COM	USB	Memory
MXE-1005	Intel® Atom™ N270 fanless embedded computer	1		4	4	1 GB DDR2
MXE-1010	Intel® Atom™ N270 fanless embedded computer	3		4	4	1 GB DDR2
MXE-1020	Intel® Atom™ N270 fanless embedded computer	1	2	4	4	1 GB DDR2

Optional Accessories

2 GB DDR2 Upgrade	Upgrade to 2 GB DDR2 memory
160 GB HDD Option	Factory-installation of 160 GB SATA hard disk drive (0 to 60°C)
32 GB SSD Option	Factory-installation of 32 GB SATA solid-state drive (0 to 70°C)
8 GB Industrial SSD Option	Factory-installation of 8 GB industrial-grade SATA solid-state drive (-40 to 85°C)
40 W AC Adapter	40 W industrial-grade AC adapter (-20 to 70°C)
Extended Temperature Option*	Extend the operating temperature of the MXE-1000 series to -20°C to 70°C

*This option guarantees cold boot of the system at -20°C and operation with 100% loading at 70°C. The industrial solid-state drive storage option is required.