

RELIABILITY

FLEXIBILITY

FAST DELIVERY

ENGINEERING
SUPPORT

ONE STOP
I/O SHOP



8400-467d

FPGA CONFIGURABLE COMPUTING SOLUTIONS



VPX FPGA Modules



XMC FPGA Modules



PMC FPGA Modules



Industry Pack FPGA Modules



DEPEND ON ACROMAG

Photo credit: U.S. Air Force

Experience counts – especially when engineering the right FPGA solution. And with more than 50 years of experience, Acromag can help you reduce your costs and increase your productivity.

24
HR
STOCK ITEM

ISO9001
AS9100



COTS

Experience
Reliability
Extended Temperature
Extended Life Cycle



Acromag: The I/O Leader

Acromag is a customer-driven manufacturer focused on developing embedded I/O products that provide the best long term value in the industry. Compare and you'll find that Acromag products offer an unmatched balance of price, performance, and features.

50 Years of I/O Experience

With 50 years of industrial I/O design experience, Acromag stands alone in the high-performance bus-board market. Developing VMEbus I/O boards since 1984, we combine our process control expertise with extensive experience in embedded computing. This background gives us unrivaled insight to many unique concerns when interfacing computer systems to various sensors and controllers in many applications.

Acromag I/O boards are commonly used in the following industries:

- military/defense
- aerospace
- transportation
- manufacturing
- semiconductors
- medical devices
- communication
- astronomy
- utilities/energy
- research labs

Quality You Can Count On

We take every measure to guarantee dependable operation. State-of-the-art manufacturing with commercial-grade and industrial components adds extra ruggedness. Multi-level inspections and specialized testing further ensure that Acromag I/O boards perform at or beyond their rated specifications.

Technical Assistance

Drawing on our wealth of industrial I/O experience, our application engineers are well qualified to help you design and develop your I/O system. Our sales staff is highly experienced in recommending products for applications ranging from simulators to machine control and countless other industrial processes.

Global Representation

Great care has been put into building a team of highly skilled representatives and distributors. They are located around the world to service your needs.

Online Ordering

Find full documentation and pricing information online. You can get quotes and even order directly on our website.

FPGAs on VPX, XMC, PMC, Industry Pack

Custom Embedded Computing with Re-Configurable FPGAs on Off-the-Shelf Mezzanine Modules

Acromag's line of configurable FPGA modules in VPX, XMC, PMC, and Industry Pack formats offer the ability to create I/O boards with customized logic. Just download instruction sets to the module's FPGA. You can use your own application program to control the module's analog or digital I/O channels for simulation, communication, diagnostics, image processing, and other applications.

Faster and easier development

To help speed your development of custom programs, Acromag offers an Engineering Design Kit. This kit provides utilities to communicate with all devices connected to the FPGA. Kits include a compiled FPGA file and example VHDL code for the local bus interface, read/writes, interrupts, and DMA transfers to the CPU.



VPX Modules

For maximum-performance FPGA computing, Acromag offers a variety of VPX bus solutions with a high-speed PCIe interface.



www.acromag.com/vpx_fpga

4

FPGA Engineering Design Kits

These software development kits help you quickly program the FPGA. Example VHDL code saves you time and effort.



www.acromag.com/edk

14

XMC Modules

Acromag's XMC solutions deliver high-performance with the flexibility of deployment on VPX, VME, CompactPCI, or other bus carrier cards.



www.acromag.com/xmc_fpga

6

Software Libraries

Function routine C libraries simplify integrating the FPGA modules with your application programs. Source code and examples are included.



www.acromag.com/libraries

15

PMC Modules

Select from cost-effective PMCs with FPGAs optimized for logic, DSP, or co-processor applications. Pick the size and performance for your needs.



www.acromag.com/pmc_fpga

8

Industry Packs

Entry-level FPGA computing applications are well-served with Industry Pack solutions. An integrated digital I/O interface speeds up logic response.



www.acromag.com/lip_fpga

10

Carrier Cards

Carriers are available for VPX, VME, PCI, and CompactPCI bus systems. Some cards have multiple mezzanine slots so you can mix FPGAs with I/O.



www.acromag.com/carriers

12

I/O Extension Modules

Acromag's AXM modules offer a front-end analog and digital I/O interface. The AXM plugs directly onto the FPGA card (Virtex-4/5 and Spartan-6).



www.acromag.com/axm

13



Photo credit: U.S. Air Force

VPX FPGA MODULES

Acromag's new VPX modules use the most advanced bus technologies to attain maximum computing speeds for high-performance embedded systems.

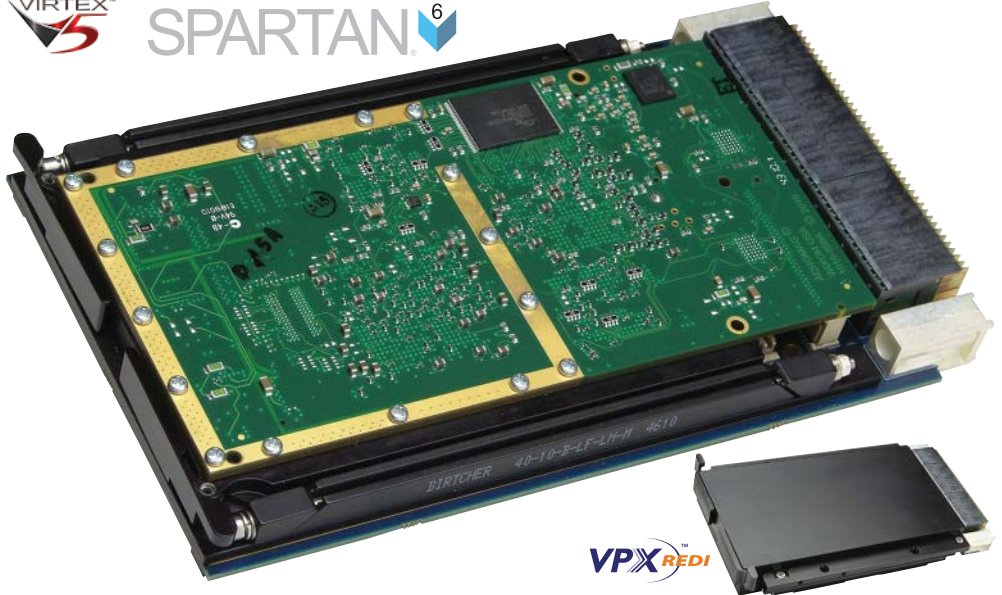

VPX FPGAs for Military and High-Speed Systems

The VPX bus provides the ultimate platform for high-performance FPGA computing applications. Take advantage of high-speed serial interconnects and multi-gigabyte connectors

Acromag offers several Virtex-5 FPGA models with varying logic capacities for the most complex computations. Or, choose a Spartan-6 FPGA version for cost-sensitive applications. Both FPGA platforms offer plenty of logic resources for algorithm acceleration and custom computing.

High-Speed PCI Express Interface

Our high-bandwidth PCIe bus 4-lane interface ensures fast data throughput.

High-Performance Memory

Dual-port SRAM enables high-speed DMA transfers to/from the CPU while simultaneously writing data to memory. Large, high-speed buffers rapidly move data in/out of the FPGA. DDR2 SDRAM memory gives the FPGA quick access to I/O port data.

Conduction-Cooled Options

Designed for very demanding defense applications, Acromag's VPX FPGA modules are ready for deployment in the most hostile conditions. Select an air-cooled or a conduction-cooled version with a -40 to 85°C range. VPX-REDI carrier cards are also available for extra cooling and maintenance requirements.

AXM Plug-in I/O Interface Cards

Configurable and customizable I/O interfaces are handled on a separate mezzanine card that plugs into the FPGA base board. A variety of these external I/O cards offer an interface for your analog and digital I/O signals.

- 16-bit A/D
- RS485 differential I/O
- LVDS I/O
- CMOS/RS485 combo
- Custom

Engineering Design Kit

Acromag provides software utilities and example source code to simplify your programming tasks and get you started quickly. A JTAG interface allows you to perform on-board VHDL simulation.



Re-configurable FPGAs on a VPX Board

Spartan-6 FPGA



VPX-SLX150

These FPGA modules are ideal for cost-sensitive applications. The Spartan-6 FPGA provides plenty of computing plus a PCIe interface and dual-port SRAM for fast data transfers. Air-cooled and conduction-cooled versions are available

Virtex-5 FPGA



VPX-VLX85/110/155

Virtex-5 FPGA modules offer more computing power and more memory to make quick work of complex logic routines and algorithms. Several FPGA sizes offer a choice of logic capacities to economically match your requirements.

Carrier Cards



VPX4810

VPX carrier cards are available in three versions: air-cooled, conduction-cooled and REDI VITA 48. These 3U carriers hold one XMC or PMC module and provide a high-speed interface to a VPX system.

See Page 12 for more info.

Front-end I/O



AXM Extension I/O

AXM modules add analog or digital I/O signal processing capabilities to FPGA modules. The AXM plugs into the FPGA module's front mezzanine to perform A/D, differential, CMOS or LVDS I/O functions.

See Page 13 for more info.

NEW! VPX Spartan-6 FPGA Modules

Model	FPGA	Logic Cells	DSP	Memory	Temperature Range
VPX-SLX150	XC6SLX150	147,433	180 DSP48A1 slices	Two 1M x 32-bit dual-port SRAM	Air-cooled, 0 to 70°C
VPX-SLX150-CC	XC6SLX150	147,433	180 DSP48A1 slices	Two 1M x 32-bit dual-port SRAM	Conduction-cooled, -40 to 85°C

NEW! VPX Virtex-5 FPGA Modules

Model	FPGA	Logic Cells	DSP	Memory	Temperature Range
VPX-VLX85	XC5VLX85T	82,944	48 DSP48E slices	Two 32M x 16-bit DDR2 SDRAM, Two 1M x 32-bit dual-port SRAM	Air-cooled, 0 to 70°C
VPX-VLX85-CC	XC5VLX85T	82,944	48 DSP48E slices	Two 32M x 16-bit DDR2 SDRAM, Two 1M x 32-bit dual-port SRAM	Conduction-cooled, -40 to 85°C
VPX-VLX110	XC5VLX110T	110,592	64 DSP48E slices	Two 32M x 16-bit DDR2 SDRAM, Two 1M x 32-bit dual-port SRAM	Air-cooled, 0 to 70°C
VPX-VLX110-CC	XC5VLX110T	110,592	64 DSP48E slices	Two 32M x 16-bit DDR2 SDRAM, Two 1M x 32-bit dual-port SRAM	Conduction-cooled, -40 to 85°C
VPX-VLX155	XC5VLX155T	155,648	128 DSP48E slices	Two 32M x 16-bit DDR2 SDRAM, Two 1M x 32-bit dual-port SRAM	Air-cooled, 0 to 70°C
VPX-VLX155-CC	XC5VLX155T	155,648	128 DSP48E slices	Two 32M x 16-bit DDR2 SDRAM, Two 1M x 32-bit dual-port SRAM	Conduction-cooled, -40 to 85°C

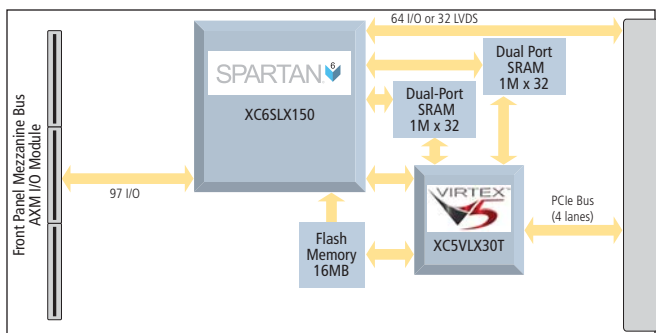

Block diagram of VPX-SLX models with Spartan-6 FPGA.

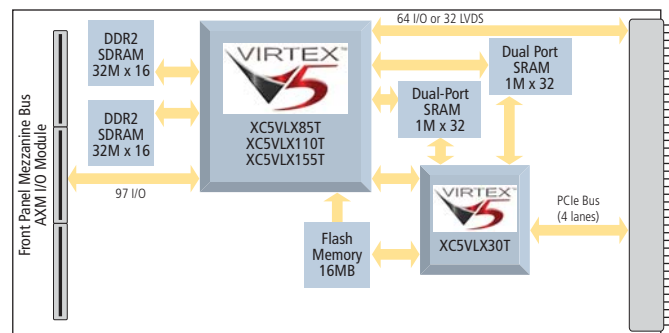

Block diagram of VPX-VLX models with Virtex-5 FPGA.

XMC FPGA MODULES

Photo credit: U.S. Army

Acromag's new XMC modules offer great flexibility and processing power for high-performance FPGA computing applications on VPX, VME or CompactPCI.

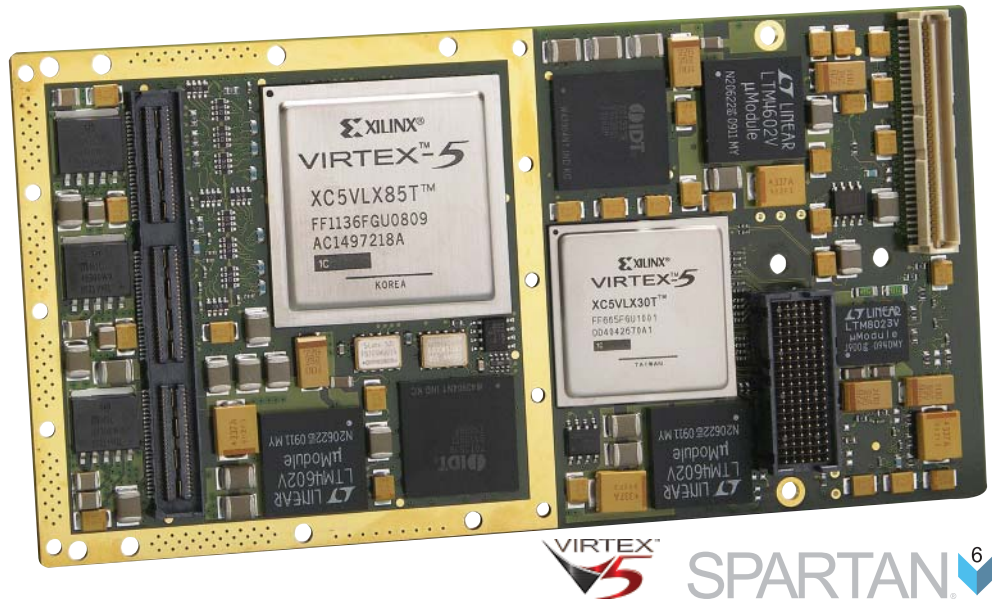

XMC FPGAs for Fast Data Rates with Bus Flexibility

XMCs add high-speed, multi-lane serial interconnects to a popular mezzanine format. Combining powerful FPGAs with a PCIe interface, Acromag has developed high-performance computing engines for use on VPX, VME or cPCI carrier cards.

Select from several Virtex-5 FPGA models with varying logic capacities for the most complex computations. Or, choose a Spartan-6 FPGA version for cost-sensitive applications. Both FPGA platforms offer plenty of logic resources for algorithm acceleration and custom computing.

High-Speed PCI Express Interface

Our high-bandwidth PCIe bus 4-lane interface ensures fast data throughput.

High-Performance Memory

Dual-port SRAM enables high-speed DMA transfers to/from the CPU while simultaneously writing data to memory. Large, high-speed buffers rapidly move data in/out of the FPGA. DDR2 SDRAM memory gives the FPGA quick access to I/O port data.

AXM Plug-in I/O Interface Cards

Configurable and customizable I/O interfaces are handled on a separate mezzanine card that plugs into the FPGA base board. A variety of these external I/O cards offer an interface for your analog and digital I/O signals.

- 16-bit A/D
- RS485 differential I/O
- LVDS I/O
- CMOS/RS485 combo
- Custom

Typical Applications

With power, speed and flexibility, these XMC modules are well-suited for many applications. Common uses include signal intelligence, simulation, communication, and imaging. The PCIe interface is ideal for distributed systems in aerospace, naval, and army vehicles.

Engineering Design Kit

Acromag provides software utilities and example source code to simplify your programming tasks and get you started quickly. A JTAG interface allows you to perform on-board VHDL simulation.

Re-configurable FPGAs on an XMC Module

Spartan-6 FPGA



XMC-SLX150

These FPGA modules are ideal for cost-sensitive applications. The Spartan-6 FPGA provides plenty of computing plus a PCIe interface and dual-port SRAM for fast data transfers. Extended temperature versions are available

Virtex-5 FPGA



XMC-VLX85/110/155

Virtex-5 FPGA modules offer more computing power and more memory to make quick work of complex logic routines and algorithms. Several FPGA sizes offer a choice of logic capacities to economically match your requirements.

Carrier Cards



VPX4810

VPX carrier cards are available in three versions: air-cooled, conduction-cooled and REDI VITA 48. These 3U carriers hold one XMC or PMC module and provide a high-speed interface to a VPX system.

See Page 12 for more info.

Front-end I/O



AXM Extension I/O

AXM modules add analog or digital I/O signal processing capabilities to FPGA modules. The AXM plugs into the FPGA module's front mezzanine to perform A/D, differential, CMOS or LVDS I/O functions.

See Page 13 for more info.

NEW! XMC Spartan-6 FPGA Modules

Model	FPGA	Logic Cells	DSP	Memory	Temperature Range
XMC-SLX150	XC6SLX150	147,433	180 DSP48A1 slices	Two banks of 256K x 32-bit dual-port SRAM	Conduction-cooled, 0 to 70°C
XMC-SLX150E	XC6SLX150	147,433	180 DSP48A1 slices	Two banks of 256K x 32-bit dual-port SRAM	Conduction-cooled, -40 to 85°C
XMC-SLX150-1M	XC6SLX150	147,433	180 DSP48A1 slices	Two banks of 1M x 32-bit dual-port SRAM	Conduction-cooled, 0 to 70°C
XMC-SLX150E-1M	XC6SLX150	147,433	180 DSP48A1 slices	Two banks of 1M x 32-bit dual-port SRAM	Conduction-cooled, -40 to 85°C

NEW! XMC Virtex-5 FPGA Modules

Model	FPGA	Logic Cells	DSP	Memory	Temperature Range
XMC-VLX85	XC5VLX85T	82,944	48 DSP48E slices	Two 32M x 16-bit DDR2 SDRAM, Two 1M x 32-bit dual-port SRAM	Conduction-cooled, 0 to 70°C
XMC-VLX85E	XC5VLX85T	82,944	48 DSP48E slices	Two 32M x 16-bit DDR2 SDRAM, Two 1M x 32-bit dual-port SRAM	Conduction-cooled, -40 to 85°C
XMC-VLX110	XC5VLX110T	110,592	64 DSP48E slices	Two 32M x 16-bit DDR2 SDRAM, Two 1M x 32-bit dual-port SRAM	Conduction-cooled, 0 to 70°C
XMC-VLX110E	XC5VLX110T	110,592	64 DSP48E slices	Two 32M x 16-bit DDR2 SDRAM, Two 1M x 32-bit dual-port SRAM	Conduction-cooled, -40 to 85°C
XMC-VLX155	XC5VLX155T	155,648	128 DSP48E slices	Two 32M x 16-bit DDR2 SDRAM, Two 1M x 32-bit dual-port SRAM	Conduction-cooled, 0 to 70°C
XMC-VLX155E	XC5VLX155T	155,648	128 DSP48E slices	Two 32M x 16-bit DDR2 SDRAM, Two 1M x 32-bit dual-port SRAM	Conduction-cooled, -40 to 85°C

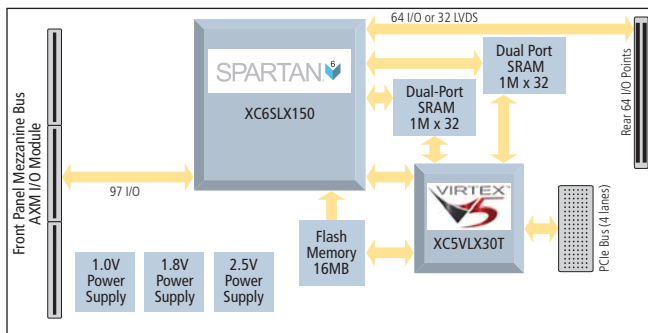

Block diagram of XMC-SLX models with Spartan-6 FPGA.

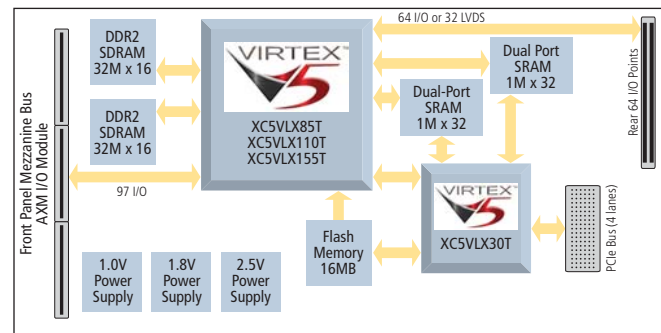

Block diagram of XMC-VLX models with Virtex-5 FPGA.

PMC FPGA MODULES

Photo credit: U.S. Navy

Acromag's popular PMC FPGA modules are a cost-effective solution for custom computing and logic applications on a variety of embedded bus architectures.

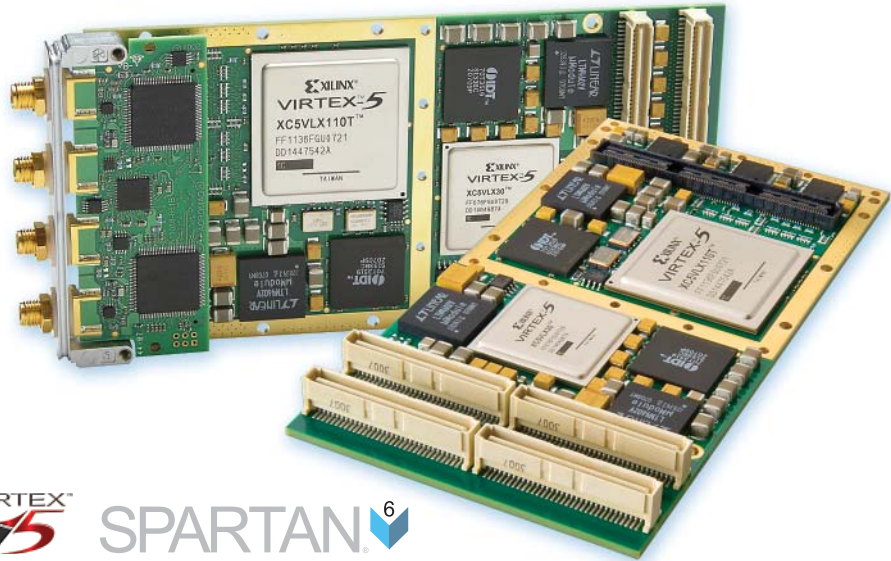

Cost-Effective PMC FPGAs

Only Acromag wraps a reconfigurable FPGA with just the features you need for fast, affordable implementation. We add a high-speed I/O interface and plenty of memory for efficient data handling. High-performance FPGA computing is now within reach for many applications.

Select from a choice of Virtex-5, Virtex-4, or Spartan-6 FPGAs optimized for logic, DSP, or co-processor applications. This lets you match the FPGA's resources and capabilities to your requirements.

High-Performance Memory

Dual-port SRAM enables high-speed DMA transfers to/from the CPU while simultaneously writing data to memory. Large, high-speed buffers enable rapid data movement in and out of the FPGA. DDR2 SDRAM memory receives data from the I/O ports for the FPGA.

High-Speed PCI-X Interface

The high-bandwidth PCI-X interface (Virtex-5 FPGA models) ensures fast data throughput. This interface supports 100MHz and 66MHz PCI bus modes.

AXM Plug-in I/O Interface Cards

Configurable and customizable I/O interfaces are handled on a separate mezzanine card that plugs into the FPGA base board. A variety of these external I/O cards offer an interface for your analog and digital I/O signals.

- 16-bit A/D
- RS485 differential I/O
- LVDS I/O
- CMOS/RS485 combo
- Custom

Typical Applications

Common uses include DSP acceleration, simulation, communication, imaging, and co-processing. The Virtex-5 FPGA is ideal for offloading of intensive computations or complex logic routines. Conduction cooling and extended temperature ranges enable use in hostile environments. A ChipScope™ Pro interface provides further flexibility.

Engineering Design Kit

Acromag provides software utilities and example source code to simplify your programming tasks and get you started quickly. A JTAG interface allows you to perform on-board VHDL simulation.

Re-configurable FPGAs on a PMC Module

Spartan-6 FPGA



PMC-SLX150

These FPGA modules are ideal for cost-sensitive applications. The Spartan-6 FPGA provides plenty of computing plus a PCI-X interface and dual-port SRAM for fast data transfers. Extended temperature versions are available

Virtex-5 FPGA



PMC-VLX85/110/155

Virtex-5 FPGA modules offer more computing power and more memory to make quick work of complex logic routines and algorithms. Several FPGA sizes offer a choice of logic capacities to economically match your requirements.

Virtex-4 FPGA



PMC-LX40/LX60/SX35

The mature Virtex-4 FPGA provides a low-cost platform for reconfigurable computing applications. Extend your existing designs or use the large base of available IP resources for a quick path to develop new systems.

Front-end I/O



AXM Extension I/O

AXM modules add analog or digital I/O signal processing capabilities to FPGA modules. The AXM plugs into the FPGA module's front mezzanine to perform A/D, differential, CMOS or LVDS I/O functions.

See Page 13 for more info.

NEW! PMC Spartan-6 FPGA Modules

Model	FPGA	Logic Cells	DSP	Memory	Temperature Range
PMC-SLX150	XC6SLX150	147,433	180 DSP48A1 slices	Two banks of 256K x 32-bit dual-port SRAM	Conduction-cooled, 0 to 70°C
PMC-SLX150E	XC6SLX150	147,433	180 DSP48A1 slices	Two banks of 256K x 32-bit dual-port SRAM	Conduction-cooled, -40 to 85°C
PMC-SLX150-1M	XC6SLX150	147,433	180 DSP48A1 slices	Two banks of 1M x 32-bit dual-port SRAM	Conduction-cooled, 0 to 70°C
PMC-SLX150E-1M	XC6SLX150	147,433	180 DSP48A1 slices	Two banks of 1M x 32-bit dual-port SRAM	Conduction-cooled, -40 to 85°C

PMC Virtex-5 FPGA Modules

Model	FPGA	Logic Cells	DSP	Memory	Temperature Range
PMC-VFX70	XC5VFX70T	71,680	128 DSP48E slices	Two 32M x 16-bit DDR2 SDRAM, Two 256K x 32-bit dual-port SRAM	Conduction-cooled, 0 to 70°C
PMC-VFX70E	XC5VFX70T	71,680	128 DSP48E slices	Two 32M x 16-bit DDR2 SDRAM, Two 256K x 32-bit dual-port SRAM	Conduction-cooled, -40 to 85°C
PMC-VLX85	XC5VLX85T	82,944	48 DSP48E slices	Two 32M x 16-bit DDR2 SDRAM, Two 256K x 32-bit dual-port SRAM	Conduction-cooled, 0 to 70°C
PMC-VLX85E	XC5VLX85T	82,944	48 DSP48E slices	Two 32M x 16-bit DDR2 SDRAM, Two 256K x 32-bit dual-port SRAM	Conduction-cooled, -40 to 85°C
PMC-VLX110	XC5VLX110T	110,592	64 DSP48E slices	Two 32M x 16-bit DDR2 SDRAM, Two 256K x 32-bit dual-port SRAM	Conduction-cooled, 0 to 70°C
PMC-VLX110E	XC5VLX110T	110,592	64 DSP48E slices	Two 32M x 16-bit DDR2 SDRAM, Two 256K x 32-bit dual-port SRAM	Conduction-cooled, -40 to 85°C
PMC-VLX155	XC5VLX155T	155,648	128 DSP48E slices	Two 32M x 16-bit DDR2 SDRAM, Two 256K x 32-bit dual-port SRAM	Conduction-cooled, 0 to 70°C
PMC-VLX155E	XC5VLX155T	155,648	128 DSP48E slices	Two 32M x 16-bit DDR2 SDRAM, Two 256K x 32-bit dual-port SRAM	Conduction-cooled, -40 to 85°C
PMC-VSX95	XC5VVSX95T	94,208	640 DSP48E slices	Two 32M x 16-bit DDR2 SDRAM, Two 256K x 32-bit dual-port SRAM	Conduction-cooled, -40 to 85°C
PMC-VSX95E	XC5VVSX95T	94,208	640 DSP48E slices	Two 32M x 16-bit DDR2 SDRAM, Two 256K x 32-bit dual-port SRAM	Conduction-cooled, -40 to 85°C

PMC Virtex-4 FPGA Modules

Model	FPGA	Logic Cells	DSP	Memory	Temperature Range
PMC-LX40	Xilinx Virtex-4	41,472	64 XtremeDSP™ slices	32Mb x 32-bit DDR DRAM, 256Kb x 36-bit dual-port SRAM	Conduction-cooled, 0 to 70°C
PMC-LX60	Xilinx Virtex-4	59,904	64 XtremeDSP™ slices	32Mb x 32-bit DDR DRAM, 256Kb x 36-bit dual-port SRAM	Conduction-cooled, 0 to 70°C
PMC-SX35	Xilinx Virtex-4	34,560	192 XtremeDSP™ slices	32Mb x 32-bit DDR DRAM, 256Kb x 36-bit dual-port SRAM	Conduction-cooled, 0 to 70°C



INDUSTRY PACK FPGAS

Photo credit: Peter Ginter, Stanford Synchrotron Radiation Laboratory

Acromag's Industry Pack FPGA modules provide a low-cost method to apply custom logic routines and signal processing algorithms to digital I/O signals.

Cyclone™ II

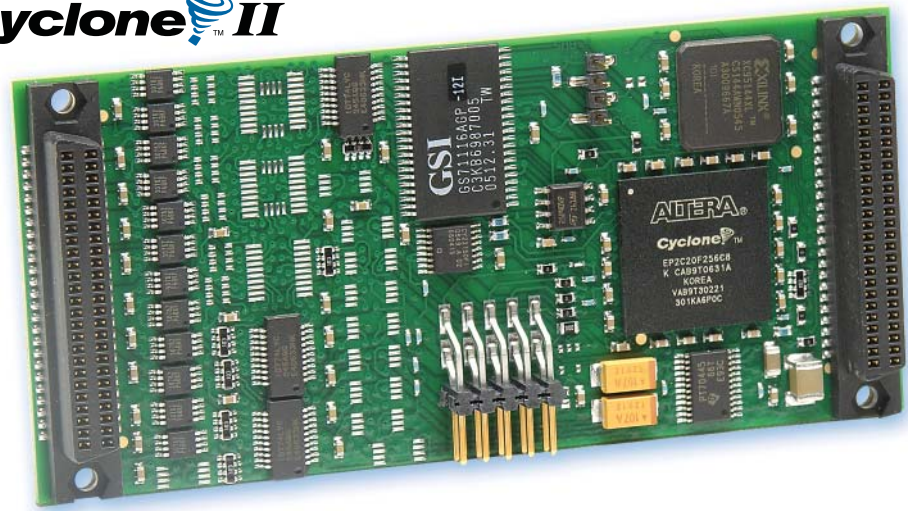

Entry-level Configurable FPGA Computing

Acromag's Industry Pack FPGA modules feature a user-customizable Altera® Cyclone®-II FPGA. These modules allow users to develop and store their own instruction sets in the FPGA for a variety of adaptive computing applications.

User application programs are downloaded through the JTAG port or via the IP bus directly into the FPGA. A pre-programmed internal CPLD facilitates initialization by acting as the bus controller during power-up and while the program is downloading. This bus controller is limited to functions necessary for power-up and downloading. After the program downloads, the FPGA takes control of the IP bus and the CPLD disables.

Typical Applications

Common FPGA applications include specialized communication systems over RS422/485 networks, test fixture simulation of signals over TTL-switched lines, and analysis of acquired data using advanced mathematical formulas such as those developed with MathWorks® MatLab® software.

Altera Cyclone-II FPGA

- 18,752 logic elements
- 239,616 distributed RAM bits
- 52 4Kb block RAMs
- 26 18 x18 embedded multipliers
- 4 digital PLL clock managers

Engineering Design Kit

Acromag provides software utilities and examples to simplify your programming and get you started quickly.

I/O Capabilities

- Bi-directional TTL I/O
- Bi-directional RS485 differential I/O
- Combination TTL and differential I/O
- Bi-directional LVDS I/O

Re-configurable FPGAs on an IP Module

Altera Cyclone-II, JTAG-configured



IP-EP200 Series

The Cyclone-II FPGA on these modules can control up to 48 TTL or 24 RS485 I/O signals or a mix of both types. Another model interfaces 24 LVDS I/O channels. Application code is downloaded through the JTAG port or via the IP bus directly into the FPGA.

Carrier Cards for Industry Packs



VME, PCI, CompactPCI

Acromag offers a variety of carrier cards to interface an IP module to your system. Select from 3U, 6U, and other form factors. The boards can carry up to five IP modules. Models offer a choice of front or rear cable connections.

See Page 12 for more info.

Industrial PCs with Plug-in I/O



I/O Server Industrial PC

Based on Acromag's Industry Pack modules, the I/O Server is an industrial PC with an integrated carrier card. You can mix and match FPGA modules along with analog, digital, and serial I/O modules.

See Bulletin 8400-540 or acromag.com for more info.

Industry Pack User-Configurable FPGA with Digital I/O

Model	FPGA	Logic Cells	TTL I/O	Differential I/O	LVDS I/O	Memory	Extended Temperature Range
IP-EP201	Cyclone II EP2C20	18,752	48	--	--	64K x 16 RAM	0 to 70°C
IP-EP201E	Cyclone II EP2C20	18,752	48	--	--	64K x 16 RAM	-40 to 85°C
IP-EP202	Cyclone II EP2C20	18,752	--	24 RS485	--	64K x 16 RAM	0 to 70°C
IP-EP202E	Cyclone II EP2C20	18,752	--	24 RS485	--	64K x 16 RAM	-40 to 85°C
IP-EP203	Cyclone II EP2C20	18,752	24	12 RS485	--	64K x 16 RAM	0 to 70°C
IP-EP203E	Cyclone II EP2C20	18,752	24	12 RS485	--	64K x 16 RAM	-40 to 85°C
IP-EP204	Cyclone II EP2C20	18,752	--	--	24	64K x 16 RAM	0 to 70°C
IP-EP204E	Cyclone II EP2C20	18,752	--	--	24	64K x 16 RAM	-40 to 85°C
IOS-EP201E	Cyclone II EP2C20	18,752	48	--	--	64K x 16 RAM	-40 to 85°C
IOS-EP202E	Cyclone II EP2C20	18,752	--	24 RS485	--	64K x 16 RAM	-40 to 85°C
IOS-EP203E	Cyclone II EP2C20	18,752	24	12 RS485	--	64K x 16 RAM	-40 to 85°C
IOS-EP204E	Cyclone II EP2C20	18,752	--	--	24	64K x 16 RAM	-40 to 85°C

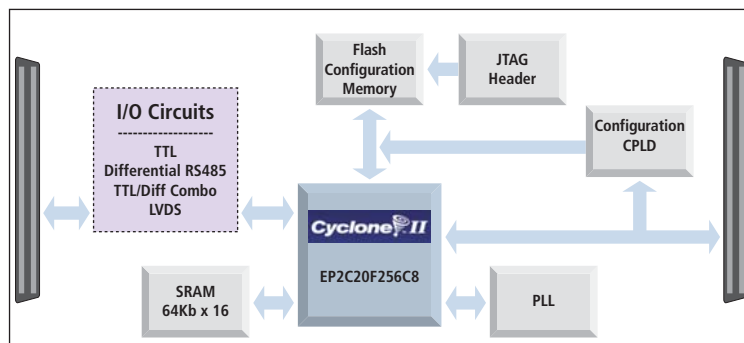



CARRIER CARDS

Photo credit: Peter Ginter, CERN

Create custom I/O boards by mixing and matching mezzanine I/O modules on a carrier card for VME, VPX, PCI, or CompactPCI systems.

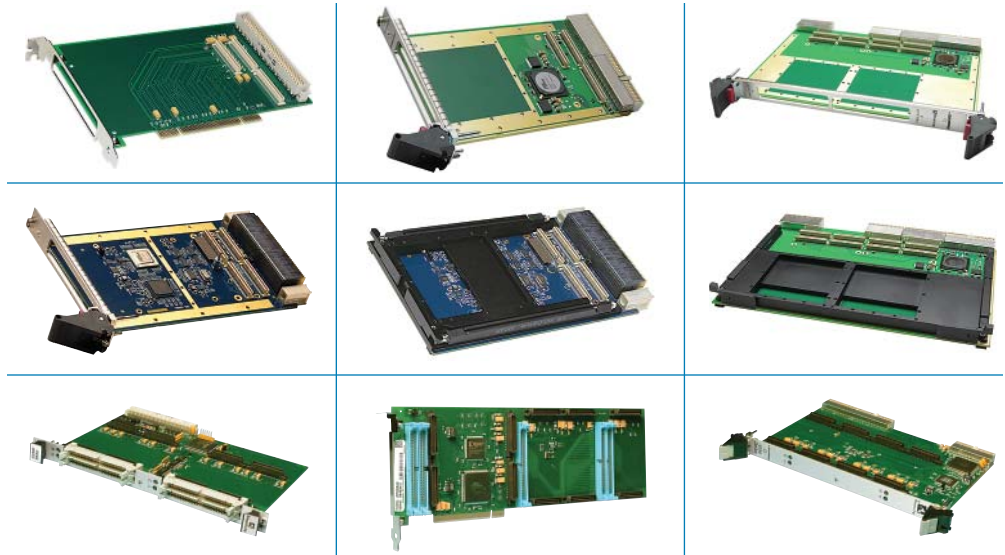

Non-intelligent Carriers

Acromag's mezzanine carrier cards offer great value. They provide an unsurpassed combination of features, performance, and price. Choose from a wide selection of sizes and bus platforms to match your application requirements.

Benefits

- Mix or match I/O functions on a carrier card
- Very high channel density can be achieved on a single carrier board to save card cage slots
- Modular format provides a cost-effective solution to develop custom I/O configurations

For more information, visit www.acromag.com

XMC/PMC Module Carrier Cards

Model	Bus	# of Slots	Field Connectors	Notes
APC-PMC	PCI half-length	1 x PMC	Front/rear 64-pin header	32-bit 66 MHz; PCI interface
APMC4110	Busless	1 x PMC	Front and rear	Provides power to PMC modules
AcPC4610CC	CompactPCI 3U	1 x PMC	Rear J1 & J2	32-bit, 33/66MHz, conduction-cooled
AcPC4610E	CompactPCI 3U	1 x PMC	Front or rear J1 & J2	32-bit, 33/66MHz
AcPC4620CC	CompactPCI 6U	2 x PMC	Rear J3 & J5	32/64-bit, 33/66MHz, conduction-cooled
AcPC4620E	CompactPCI 6U	2 x PMC	Front or rear J3 & J5	32/64-bit, 33/66MHz
VPX4810	VPX 3U	1 x PMC/XMC	Front or Rear P2	64-bit, 66/133MHz, PCIe x8 interface
VPX4810-CC	VPX 3U	1 x PMC/XMC	Rear P2	Same as VPX4810 plus conduction frame
VPX4810-REDI	VPX 3U	1 x PMC/XMC	Rear P2	Same as VPX4810 plus REDI VITA 48 cover

Industry Pack Module Carrier Cards

Model	Bus	# of IP Slots	Field Connectors	Notes
AVME9630/9660	VMEbus 3U or 6U	2 or 4	Front 50-pin headers	
AVME9668	VMEbus 6U	4	Front SCSI-2 connectors	Supports 8, 32MHz IP clocks
AVME9670/9675	VME64 6U	2 or 4	Rear P0 & P2 high-density	Jumper or geographical addressing
AcPC8625	CompactPCI 6U	4	Rear J4 & J5	Transition module available
AcPC8630/8635	CompactPCI 3U	2	Front CHAMP or rear J2	Transition module available
APC8620A/21A	PCI full/half-length	5 or 3	50-pin headers	
APCe8650	PCI Express	4	50-pin headers	



I/O EXTENSION MODULES

Photo credit: Peter Ginter, Fermilab

Plug-in I/O modules provide a convenient method for direct connection of the I/O to the FPGA with optimal performance.



AXM Plug-in I/O Modules (for PMC/XMC FPGA cards)

Configurable and customizable I/O interfaces are handled on a separate mezzanine card that plugs into the FPGA base board. A variety of these external I/O cards offer a front-end interface for your analog and digital I/O signals.

Custom I/O functions

Call the factory to discuss development of custom AXM modules to meet your unique requirements.



AXM-A30
Analog I/O plug-in extension module.



AXM-D0x
Digital I/O plug-in extension module.

I/O Extension Cards for FPGA Modules

Model	Analog I/O	Digital I/O	Compatible FPGA Modules
AXM-A30	Two channels of 16-bit A/D	--	Virtex-4/5, Spartan-6 FPGAs
AXM-D02	--	30 RS485 differential I/O lines	Virtex-4/5, Spartan-6 FPGAs
AXM-D03	--	16 CMOS and 22 RS485 differential I/O lines	Virtex-4/5, Spartan-6 FPGAs
AXM-D04	--	30 LVDS I/O lines	Virtex-4/5, Spartan-6 FPGAs
AXM-???	Acromag can develop custom I/O function modules. Consult factory for details.		
AXM-EDK	Test board with JTAG port. Included with Spartan-6 and Virtex-4/5 Engineering Design Kits (EDK).		



ENGINEERING DESIGN KIT

Acromag's software design kits simplify the process of developing custom FPGA programs.



EDK Software

One key to the success of your FPGA project is how quickly you learn to control the capabilities of the FPGA and its interaction with other components on the module. To save time in this stage, Acromag provides extensive example VHDL code covering all of the major functions of the FPGA module. This code is provided as both source code and as compiled code in the Engineer Design Kit.

Additionally, example code is pre-loaded into flash memory on the FPGA module. This lets you exercise the module and all of its functionality immediately out of the box.

The Engineering Design Kit provides the basic information required to develop a custom FPGA program for download to the FPGA. Utilities help you load VHDL into the FPGA and establish DMA transfers between the FPGA and the CPU. It is recommended that users be familiar with Xilinx® or Altera® development tools.

Engineering Design Kit includes:

- Parts list and location
- Schematics
- Compiled FPGA file
- Example VHDL code (provided as selectable blocks of code)
 - » Local Bus: example of interface between PCI accelerator and FPGA
 - » SRAM: example for read and write transfers to SRAM
 - » SDRAM: example for read, write and refresh to SDRAM
 - » Interrupts: examples of change-of-state monitoring and interrupts to the PCI bus
 - » Field I/O: examples of direction control and I/O read/write
 - » Pin definitions: configuration file defining all user I/O pins communicating with the FPGA

For Virtex-5 FPGAs

[PMC-VLX-EDK](#)
[PMC-VSX-EDK](#)
[PMC-VFX-EDK](#)
[XMC-VLX-EDK](#)

Each package includes the AXM-EDK test board.

For Spartan-6 FPGAs

[PMC-SLX-EDK](#)
[XMC-SLX-EDK](#)

Includes AXM-EDK test board.

For Virtex-4 FPGAs

[PMC-LX-EDK](#)
[PMC-SX-EDK](#)

Each package includes the AXM-EDK test board.

For Cyclone-II FPGAs

[IP-EP200-EDK](#).



SOFTWARE SUPPORT

Photo credit: Peter Ginter, Fermilab

Acromag software development tools for your OS save you time and effort.

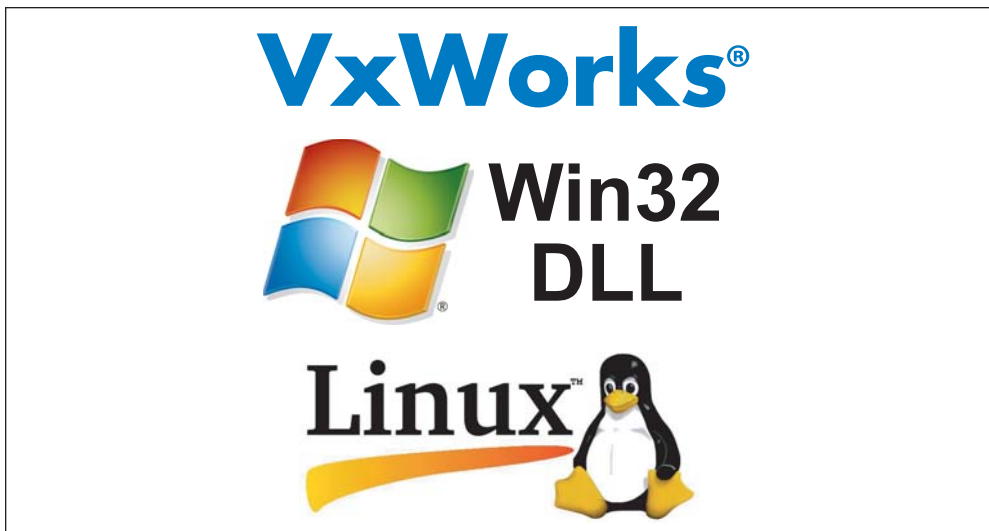

Function Routine C Libraries

These software development tools simplify the integration of Acromag I/O boards with your application programs.

Acromag offers a library of function routines targeted for a VxWorks® operating system. These routines and example programs help develop the interface between Acromag I/O boards and your application program. C source code is included for easy customization.

DLL drivers simplify the interface between the I/O boards and your Windows®-based application program. This package provides DLL driver level support for Acromag's complete line of PMC, PCI and CompactPCI products. Also, the C source code demonstration programs provide easy-to-use tools to test operation of your I/O modules.

A free Linux® example application programming interface is available for download on Acromag's website to assist open-source developers. This software provides I/O function routines for Acromag's mezzanine modules and carrier cards. Includes C source code.

VxWorks

[IPSW-API-VXW](#)

For Industry Packs

[PMCSW-API-VXW](#)

For PMC, XMC, PCI, cPCI, VPX

Windows DLL

[IPSW-API-Win](#)

For Industry Packs

[PCISW-API-Win](#)

For PMC, XMC, PCI, cPCI, VPX

Linux

[IPSW-Linux](#)

For Industry Packs
(free download only)

[PCISW-Linux](#)

For PMC, XMC, PCI, cPCI, VPX
(free download only)



Acromag I/O. Depend on it.

The screenshot shows the Acromag website homepage. At the top, there's a navigation bar with links for Products, Support, News/Events, About Us, Contact Us, and My Account. Below this is a large banner image of a submarine with the text "RELIABILITY" and a list of features: 7-year warranty, ISO 9001, AS9100 certified, Long-term availability, and 50 years of experience. To the right of the banner is a "NEWS" section with three articles: "New XMC Module with Spartan-6 FPGA", "RTD Signal Conditioners w/ USB Configuration", and "Single/Dual MIL-STD-1553 Interface". The bottom of the page features a footer with contact information, a "MADE IN USA" logo, and ISO9001 AS9100 certification.

Acromag - Ethernet I/O, Signal Conditioning, Embedded I/O, Industrial PC, FPGA, Computing - Microsoft Internet Explorer provided

http://www.acromag.com/

Acromag - Ethernet I/O, Signal Conditioning, Em...

Acromag THE LEADER IN INDUSTRIAL I/O

Google Site Search

Login 0 item in cart

Products Support News/Events About Us Contact Us My Account

RELIABILITY ○
FLEXIBILITY ●
FAST DELIVERY ●
ENGINEERING SUPPORT ●
ONE-STOP I/O SHOP ●

RELIABILITY

- 7-year warranty
- ISO 9001, AS9100 certified
- Long-term availability
- 50 years of experience

Photo credit: US Navy

Featured Products Embedded I/O Boards FPGA Computing Industrial PCs Ethernet & Network I/O Isolators & Splitters Signal Conditioners

XMC Virtex-5 or Spartan-6 FPGA

New XMC modules offer user-configurable FPGAs with up to 155K logic cells for custom signal processing routines. Large, high-speed memory and PCIe interface efficiently transfer data. [Read more...](#)

Ethernet I/O with 64-channel A/D

These EtherStax I/O modules provide a rugged, high-density, and high-speed solution to interface a large quantity of analog input signals to SCADA and distributed I/O systems. [Read more...](#)

I/O Server Industrial PC

Acromag's Industrial I/O Server is a rugged industrial PC with truly integrated support for user I/O. A built-in carrier card interfaces up to four plug-in I/O modules to the Intel Atom® CPU. [Read more...](#)

NEWS

02/08/11
New XMC Module with Spartan-6 FPGA
[READ MORE](#)

01/18/11
RTD Signal Conditioners w/ USB Configuration
[READ MORE](#)

10/27/10
Single/Dual MIL-STD-1553 Interface
[READ MORE](#)

CLICK TO CHAT

SUBSCRIBE TO NEWSLETTER

MAIL ME A CATALOG

f t in YouTube

SHARE

Home Login My Account Create an Account Checkout Sitemap Terms & Conditions

MADE IN USA ISO9001 AS9100

Visit us at www.acromag.com!

- Product data sheets, manuals, and price information
- Order online with your credit card or purchase order
- Technical support, tutorials, and application notes
- Subscribe to our monthly e-newsletter

8400-467d © Acromag, Inc. 2011. Data subject to change without notice. Printed in USA 3/2011



Acromag, Inc.
P.O. Box #437,
30765 South Wixom Road,
Wixom, MI 48393-7037 USA

Tel: 248-295-0310
Fax: 248-624-9234
www.acromag.com
Email: solutions@acromag.com